

### SMV SmartLine Multivariable Transmitter Specification 34-SM-03-92, March 2017



#### Introduction

The SMV 800 combines sensor technologies for differential pressure, static pressure and temperature with the latest microprocessor technology to provide highly accurate compensated flow measurement. When paired with the other SmartLine unique features the SMV 800 delivers the highest levels of safety, reliability and efficiency available. The SmartLine family is also fully tested and compliant with Experion<sup>®</sup> PKS providing the highest level of compatibility assurance and integration capabilities.

#### Best in Class Features:

- Accuracy up to 0.0400% for Differential pressure
- Accuracy up to 0.0375% for Static pressure
- Accuracy up to 0.2 Deg C for Temperature
- Mass Flow Reference Accuracy: up to 0.6%
- Automatic static pressure & temperature compensation
- Rangeability up to 400:1
- Compensated flow response time of up to 2x per second
- Multiple local display capabilities
- External zero, span, & configuration capability
- Polarity insensitive electrical connections
- Comprehensive on-board diagnostic capabilities
- Integral Dual Seal design for highest safety based on ANSI/NFPA 70-202 and ANSI/ISA 12.27.0
- World class overpressure protection
- Modular design characteristics

#### Communications/Output Options:

- 4-20mA DC (Analog)
- Honeywell Digitally Enhanced (DE) Single or Multivariable
- HART<sup>®</sup> (version 7.0)

All transmitters are available with the above listed communication protocols.



**Figure 1 – SMV 800 Multivariable Transmitters feature field-proven piezoresistive sensor technology**

#### Span & Range Limits:

| Model    | URL                      | LRL                      | Max Span                 | Min Span                 |
|----------|--------------------------|--------------------------|--------------------------|--------------------------|
| PV1 - DP | "H <sub>2</sub> O (mbar) | "H <sub>2</sub> O (mbar) | "H <sub>2</sub> O (mbar) | "H <sub>2</sub> O (mbar) |
| SMA810   | 25 (62.50)               | -25 (-62.5)              | 25 (62.50)               | 1.0 (2.5)                |
| SMA845   | 400 (1000)               | -400 (-1000)             | 400 (1000)               | 1.0 (2.5)                |
| SMG870   | 400 (1000)               | -400 (-1000)             | 400 (1000)               | 1.0 (2.5)                |
| PV2 - SP | psiA (bara)              | psiA (bara)              | psiA (bara)              | psiA (bara)              |
| SMA810   | 100 (7.0)                | 0 (0)                    | 100 (7.0)                | 5 (0.35)                 |
| SMA845   | 1500 (104)               | 0 (0)                    | 1500 (104)               | 30 (2.1)                 |
| PV2 - SP | psig (barg)              | psig (barg)              | psig (barg)              | psig (barg)              |
| SMG870   | 4500 (310)               | -14.7 (-1)               | 4500 (310)               | 60 (4.2)                 |

## Description

Honeywell's SMV 800 Smart Multivariable Flow Transmitter extends our proven "smart" technology to the measurement of three separate process variables with the ability to calculate compensated mass or volume flow rate as a fourth process variable according to industry standard methods for air, gases, steam and liquids.

## Unique Indication/Display

### Advanced Graphics LCD Display Features

- Modular (may be replaced in the field)
- 0, 90, 180, & 270 degree position adjustments
- Standard and custom measurement units available.
- Up to eight display screens with 3 formats are possible (Large PV with Bar Graph or PV with Trend Graph)
- Configurable screen rotation timing (3 to 30 sec)
- Display Square Root capabilities may be set separately from the 4-20mA dc output signal
- Multiple language capability. (EN, DE, FR, IT, ES, RU, TU, CH, & JP)

## Diagnostics

SmartLine transmitters all offer digitally accessible diagnostics which aid in providing advanced warning of possible failure events minimizing unplanned shutdowns, providing lower overall operational costs

## Configuration Tools

### Integral Three Button Configuration Option

Suitable for all electrical and environmental requirements, SmartLine offers the ability to configure the transmitter and display via three externally accessible buttons except for the flow related parameters. Zero/span capabilities are also optionally available via these buttons with or without selection of a display option.

### Hand Held Configuration

SmartLine transmitters feature two-way communication and configuration capability between the operator and the transmitter. This is accomplished via Honeywell's field-rated Multiple Communication Configurator (MCT404).

The MCT404 is capable of field configuring HART SMV devices, for all parameters other than flow configuration, can be ordered for use in intrinsically safe environments. All Honeywell transmitters are designed and tested for compliance with the offered communication protocols and are designed to operate with any properly validated hand held configuration device.

## Measurement Types:

SMV is capable of mass flow measurements for liquids, gases, and superheated and saturated steam.

## Personal Computer Configuration

Honeywell's PC Based configuration Toolkit SCT3000 provides an easy way to configure the SMV800 DE devices. SMV800 HART Device can be configured using Device Description based DCS Hosts and Asset Management Systems. HART device can also be configured using PC based DTMs. DTMs provide enhanced features like:

- Easy to use Flow Configuration
- Units Preference: Configurable Engineering units
- Auto Calculation of Viscosity and Density Coefficients, Auto Calculation of K User, Beta Factor
- Export and Import Configurations to/from external file with predefine schema/format
- Summary Page

## Primary Element Compatibility

**FLOW:** The SMV is compatible with and provides dynamic calculation capabilities. SMV800 supports Advanced Algorithms and ASME 1989 Algorithms which is User selectable option in the DD / DTM Tools. Advanced Algorithm option supports the following Primary Elements with SMV800 HART Protocol:

- Orifice Plates (ASME MFC-3M & AGA No 3/ISO 5167/GOST 8.586).
- Integral Orifice
- Small Bore Orifice (ASME MFC -14M)
- Conditional Orifice (ISO5167-2003)
- Nozzles (ASME MFC-3M/ISO 5167/GOST 8.586).
- Venturi Tubes (ASME MFC-3M/ISO 5167/GOST).
- Averaging Pitot Tubes
- V-Cone®, Wafer Cone, Wedge

ASME 1989 Algorithm Option supports the following Primary Elements with SMV800 HART and DE protocol:

- Orifice (Flange Taps  $D \geq 2.3$  inches, Flange Taps  $2 \leq D \leq 2.3$ , Corner Taps, Orifice D and D/2 Taps, Orifice 2.5 and 8D Taps)
- Venturi (Machined Inlet, Rough Cast Inlet, Rough Welded Sheet-Iron Inlet, Leopold, Gerand, Venturi Tube, Low-Loss Venturi Tube)
- Nozzle (Long Radius, Venturi Nozzle)
- Various Preso Ellipse Pitot Tubes with varying Pipe Sizes
- Other Pitot Tubes

## Primary Element Compatibility, continued

**Fixed Parameters:** Fixed Cd, Y1, Viscosity, Density are supported for user to customize the flow calculation

**Temperature:** The SMV also has the following temperature input options:

- **RTD** (2,3,4 wires): PT25, PT100\*, PT200, PT500, PT1000 (\*DE models use only PT100 RTD)
- **Universal Input: RTD** PT25, PT100, PT200, PT500, PT1000 and **Thermocouple:** Type B\*, E, J, K, N\*, R\*, S\*, T.

\*B, N, R, S Type inputs are only available with HART protocol

## Mass Flow Calculation

Mass Flow Compensation can be selected for Standard Compensations by user for Gas, Liquid and Steam without limitation on primary elements.

Mass Flow Compensation can be selected for Dynamic Compensation by the user from: ASME-MFC-3M, ISO5167, Gost-8.586, for Orifice Plate, Nozzle and Venturri, AGA3 for Orifice, and Calculation Support for Averaging Pitot Tube, VCone, Wafer Cone, Wedge and Integral Orifice and Conditional Orifice are also available. Mass Flow Calculations also support user Fixed Input Parameters for Customizing the Calculations.

## System Integration

- SmartLine communications protocols all meet the most current published standards for HART/DE
- Integration with Honeywell's Experion PKS offers the following unique advantages.
  - Messaging & Maintenance Mode Indication
  - Tamper reporting
  - FDM Plant Area Views with Health summaries
  - All SMV 800 units are Experion tested to provide the highest level of compatibility assurance

## Automatic Density Compensation

Using the configuration software, the SMV can be configured with the primary element type and the physical parameters of the fluid measured. This method dynamically compensates for fluid characteristics such as discharge coefficients, gas expansion factors, density, and viscosity as well as installation issues like upstream pipe size using the above referenced algorithms.

## Basic Flow Density Compensation

This conventional calculation method is based on flow factors being manually entered

## Modular Design

To help contain maintenance & inventory costs, all SMV 800 transmitters are modular in design supporting the user's ability to replace meter bodies, indicators or change electronic modules without affecting overall performance or approval body certifications. Each meter body is uniquely characterized to provide in-tolerance performance over a wide range of application variations in temperature and pressure and due to the Honeywell advanced interface, electronic modules may be swapped without losing in-tolerance performance characteristics.

## Modular Features

- Meter body replacement
- Replaceable electronics/comm modules\*
- Add or remove integral indicators\*
- Add or remove lightning protection (terminal connection)\*

\* Field replaceable in all electrical environments (including IS) except flameproof without violating agency approvals. With no performance effects, Honeywell's unique modularity results in lower inventory needs and lower overall operating costs.

## Performance Specifications

### Digital Reference Accuracy <sup>2</sup> (conformance to +/-3 Sigma)

TABLE I

|                     | Model  | URL                              | LRL                                | Min Span                      | Maximum Turndown Ratio | Stability (% URL/Year) | Reference Accuracy <sup>1</sup> (% Span) |
|---------------------|--------|----------------------------------|------------------------------------|-------------------------------|------------------------|------------------------|--|
| PV1<br>Differential | SMA810 | 25 in H <sub>2</sub> O/62.5mbar  | -25 in H <sub>2</sub> O/-62.5mbar  | 1 in H <sub>2</sub> O/2.5mbar | 25:1                   | 1.0                    | 0.0400                                   |
|                     | SMA845 | 400 in H <sub>2</sub> O/1000mbar | -400 in H <sub>2</sub> O/-1000mbar | 1 in H <sub>2</sub> O/2.5mbar | 400:1                  | 0.0625                 |  |
|                     | SMG870 |                                  |                                    |                               |                        |                        |  |
| PV2<br>Static       | SMA810 | 100 psiA/7 bara                  | 0 psiA/0 bara                      | 5 psiA/0.35 bara              | 20:1                   | 0.125                  | 0.0375                                   |
|                     | SMA845 | 1500 psiA/104 bara               | 0 psiA/0 bara                      | 30 psiA/2.1 bara              | 50:1                   | 0.008                  |  |
|                     | SMG870 | 4500 psig/310 barg               | -14.7 psig/-1.0 barg               | 60 psig/4.2 barg              | 75:1                   | 0.025                  |  |

Zero and span may be set anywhere within the listed (URL/LRL) range limits

% Span per 28°C (50°F)

### Digital Accuracy at Specified Span, Temperature and Static Pressure

(Combined Zero & Span, conformance to +/-3 Sigma)

TABLE II

|   | Model  | URL                     | Accuracy <sup>1</sup> (% of Span) |        |       | Temperature Effect<br>% Span per 28oC (50oF)                           |       | Static Line Pressure Effect<br>(% Span/1000psi) <sup>3</sup>           |       |       |
|---|--------|-------------------------|-----------------------------------|--------|-------|--|-------|--|-------|-------|
|   |        |                         | For Spans Below                   | A      | B     | C  | D     | E  | F     | G     |
| PV1<br>Differential   | SMA810 | 25 in H <sub>2</sub> O  | 1:1                               | 0.015  | 0.025 | 25   | 0.100 | 0.1000   | 0.180 | 0.080 |
|   | SMA845 | 400 in H <sub>2</sub> O | 16:1                              |        |       |  | 0.075 | 0.0250   | 0.200 | 0.025 |
|   | SMG870 | 400 in H <sub>2</sub> O | 16:1                              |        |       |  |       |  |       |       |
| PV2<br>Static   | SMA810 | 100psiA                 | 2:1                               | 0.0125 | 0.025 | 50   | 0.05  | 0.0500   | n/a   |       |
|   | SMA845 | 1500psiA                | 10:1                              |        |       | 150  | 0.055 | 0.0200   |       |       |
|   | SMG870 | 4500psig                | 10:1                              |        |       | 450  |       |  |       |       |
| Turn Down Effect  |        |                         |                                   |        |       | Temp Effect  |       | Static Effect <sup>3</sup>   |       |       |
| ± $\left[ A + B \left( \frac{C}{\text{Span}} \right) \right]$ |        |                         |                                   |        |       | ± $\left[ D + E \left( \frac{\text{URL}}{\text{Span}} \right) \right]$ |       | ± $\left[ F + G \left( \frac{\text{URL}}{\text{Span}} \right) \right]$ |       |       |

### Typical Calibration Frequency:

PV1 and PV2 calibration verification is recommended every four (4) years

#### Notes:

<sup>1</sup> Digital terminal based accuracy – Includes the combined effects of linearity, hysteresis and repeatability. Analog output adds 0.005% of span error.

<sup>2</sup> For zero based spans and reference conditions of 25°C (77°F), 0 static pressure, 10 to 55% RH and 316SS barrier diaphragm.

<sup>3</sup> Static Line Pressure effect for SMA810 is % span/25 psi

## Performance Specifications

### Digital PV3 Temperature Reference Accuracy <sup>2</sup> (conformance to +/-3 Sigma)

Table III

| Input Type                       | Maximum Range Limits |              | Digital Accuracy (+/-) <sup>1</sup> | Min Span   | Stability (% ULR/year) | Standards                        |
|----------------------------------|----------------------|--------------|-------------------------------------|------------|------------------------|----------------------------------|
| <b>RTD (2,3,4 wire)</b>          | <b>° C</b>           | <b>° F</b>   | <b>° C</b>                          | <b>° C</b> | <b>%</b>               |                                  |
| Pt25 <sup>4</sup>                | -200 to 850          | -328 to 1562 | 1.0                                 | 1.0        | 0.01                   | IEC751:1990 ( $\alpha=0.00385$ ) |
| Pt100                            | -200 to 850          | -328 to 1562 | 0.20                                | 1.0        | 0.01                   | IEC751:1990 ( $\alpha=0.00385$ ) |
| Pt200 <sup>4</sup>               | -200 to 850          | -328 to 1562 | 0.40                                | 1.0        | 0.01                   | IEC751:1990 ( $\alpha=0.00385$ ) |
| Pt500 <sup>4</sup>               | -200 to 850          | -328 to 1562 | 0.24                                | 1.0        | 0.01                   | IEC751:1990 ( $\alpha=0.00385$ ) |
| Pt1000 <sup>4</sup>              | -200 to 500          | -328 to 932  | 0.20                                | 1.0        | 0.01                   | IEC751:1990 ( $\alpha=0.00385$ ) |
| <b>Thermocouples<sup>3</sup></b> | <b>° C</b>           | <b>° F</b>   | <b>° C</b>                          | <b>° C</b> | <b>%</b>               |                                  |
| B <sup>4</sup>                   | 200 to 1820          | 392 to 3308  | 2.00                                | 1.0        | 0.01                   | IEC 584-1 (ITS-90)               |
| E                                | -200 to 1000         | -328 to 1832 | 0.40                                | 1.0        | 0.01                   | IEC 584-1 (ITS-90)               |
| J                                | -200 to 1200         | -328 to 2192 | 0.50                                | 1.0        | 0.01                   | IEC 584-1 (ITS-90)               |
| K                                | -200 to 1370         | -328 to 2498 | 0.50                                | 1.0        | 0.01                   | IEC 584-1 (ITS-90)               |
| N <sup>4</sup>                   | -200 to 1300         | -328 to 2372 | 0.80                                | 1.0        | 0.01                   | IEC 584-1 (ITS-90)               |
| R <sup>4</sup>                   | -50 to 1760          | -58 to 3200  | 2.00                                | 1.0        | 0.01                   | IEC 584-1 (ITS-90)               |
| S <sup>4</sup>                   | -50 to 1760          | -58 to 3200  | 2.00                                | 1.0        | 0.01                   | IEC 584-1 (ITS-90)               |
| T                                | -250 to 400          | -418 to 752  | 0.40                                | 1.0        | 0.01                   | IEC 584-1 (ITS-90)               |

#### Notes:

1. Digital Accuracy is accuracy of the digital value accessed by the Host system and the handheld communicator
2. Analog Output Accuracy is applicable to the 4 to 20 mA Signal output
3. For TC inputs, CJ accuracy of 0.25°C shall be added to digital accuracy to calculate the total digital accuracy
4. These input types are only available with HART protocol

Total analog accuracy is the sum of digital accuracy and 0.005% of span.

Ambient Temperature Effect Digital Accuracy: For RTD Inputs, 0.0015°C/°C/. For T/C Inputs: 0.005°C/°C

Analog Output: 0.0005% of span/°C

### PV4 Mass Flow Reference Accuracy: 0.6% over 20:1 flow range, calculated every 500ms<sup>1,2</sup>

<sup>1</sup> Flow performance specifications assume dynamic compensation and is applicable for SMA845 and SMG870

<sup>2</sup> Applicable standards and installations per ASME MFC 3M or ISO 5167-1 for un-calibrated orifice; Bigger than 2.8 inch Pipe Diameter; (0.2 < beta < 0.6 Orifice). DP Turn down 16:1; Reference accuracy does not include RTD sensor accuracy.

**Operating Conditions – All Models**

| Parameter  | Reference Condition   |      | Rated Condition         |                         | Operative Limits   |            | Transportation and Storage |            |
|--|---|------|-------------------------|-------------------------|--|------------|----------------------------|------------|
|  | °C  | °F   | °C                      | °F                      | °C   | °F         | °C                         | °F         |
| <b>Ambient Temperature<sup>1</sup></b><br>SMA810, SMA845, SMG870   | 25±1  | 77±2 | -40 to 85               | -40 to 185              | -40 to 85  | -40 to 185 | -55 to 120                 | -67 to 248 |
| <b>Meter Body Temperature<sup>2</sup></b><br>SMA810, SMA845, SMG870  | 25±1  | 77±2 | -40 to 110 <sup>1</sup> | -40 to 230 <sup>1</sup> | -40 to 125   | -40 to 257 | -55 to 120                 | -67 to 248 |
| <b>Humidity %RH</b>  | 10 to 55  |      | 0 to 100                |                         | 0 to 100   |            | 0 to 100                   |            |
| <b>Vac. Region – Min. Pressure</b><br><b>mmHg absolute</b><br><b>inH<sub>2</sub>O absolute</b>   | Atmospheric<br>Atmospheric  |      | 25<br>13                |                         | 2 (short term) <sup>3</sup><br>1 (short term) <sup>3</sup> |            |                            |            |
| <b>Supply Voltage</b><br><b>Load Resistance</b>  | <b>HART Models:</b> 10.8 to 42.4 Vdc at terminals (IS version limited to 30v)<br>0 to 1440 ohm (as shown in Figure 2)<br><b>DE Models:</b> 15V to 42.4 Vdc at terminals (IS version limited to 30V, XP and Non Sparking/ Non Incentive, 42 Volts.)<br>0 to 900 ohm (as shown in Figure 2) |      |                         |                         |  |            |                            |            |
| <b>Maximum Allowable Working Pressure (MAWP)<sup>4,5</sup></b><br>(SMV 800 products are rated to Maximum Allowable Working Pressure. MAWP depends on Approval Agency and transmitter materials of construction.) | <b>Standard:</b><br>SMA810 = 100 psiA, 7.0 BarA <sup>6</sup><br>SMA845 = 3000 psiA, 207 BarA <sup>6</sup><br>SMG870 = 4500 psiG, 310 BarG <sup>6</sup>  |      |                         |                         |  |            |                            |            |

<sup>1</sup> LCD Display operating temperature -20 °C to +70 °C (-4 °F to 158 °F) . Storage temperature -30 °C to 80 °C (-22 °F to 176 °F).

<sup>2</sup> For CTFE fill fluid, the rating is -15 to 110 °C (5 to 230 °F)

<sup>3</sup> Short term equals 2 hours at 70 °C (158°F)

<sup>4</sup> MAWP applies for temperatures -40 °C to 125 °C (-40 °F to 257 °F). Static Pressure Limit is de-rated to 3,000 psi (207 BarA) for -26°C to -40°C (-14.8 °F to -40 °F). Use of graphite o-rings de-rates transmitter to 3,625 psi. Use of ½" - process adaptors with graphite o-rings de-rates transmitter to 3,000 psi.

<sup>5</sup> Consult factory for MAWP of SMV 800 transmitters with CRN approval.

<sup>6</sup> The MAWP is intended as a pressure safety limit. Honeywell does not recommend use above the PV 2 Upper Range Limit.

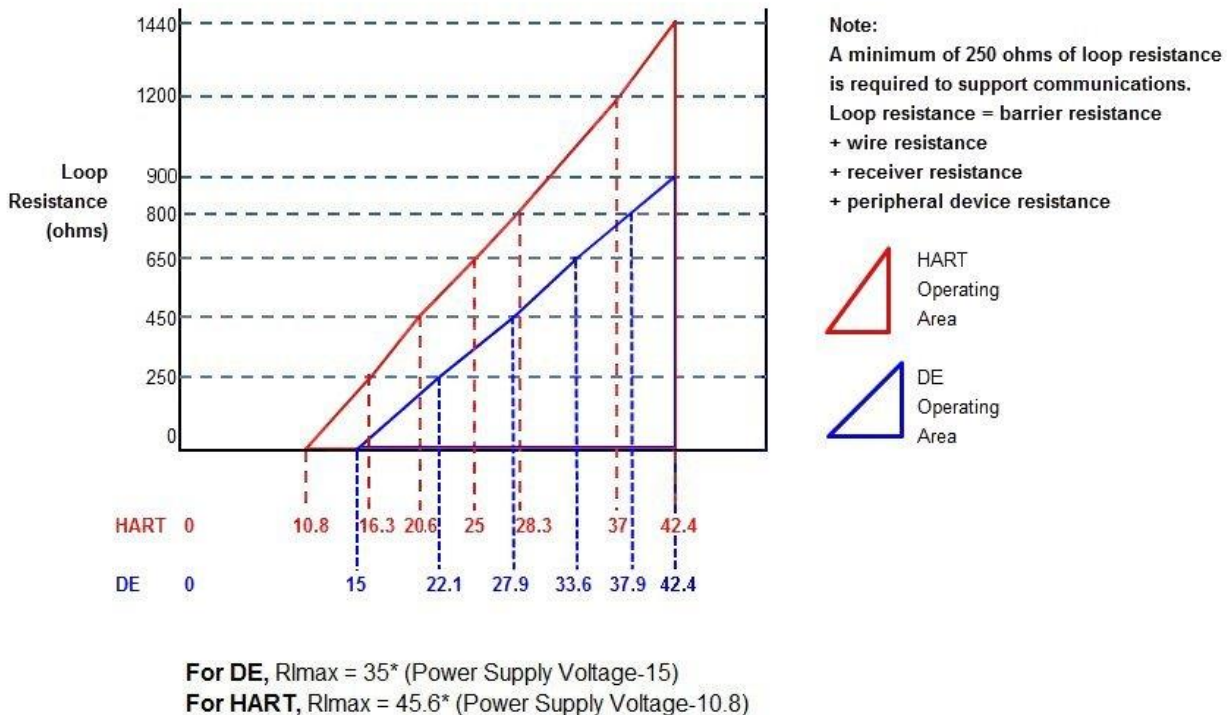

**Figure 2 - Supply voltage and loop resistance chart & calculations (HART/DE Protocols)**

**Performance Under Rated Conditions – All Models**

| Parameter  | Description  |                        |                     |                        |                    |                      |  |                       |               |               |                      |                        |                        |
|--|--|------------------------|---------------------|------------------------|--------------------|----------------------|--|-----------------------|---------------|---------------|----------------------|------------------------|------------------------|
| <b>Analog Output</b><br><b>Digital Communications:</b>                   | Two-wire, 4 to 20 mA (HART & DE Transmitters only)<br>Honeywell DE, HART 7 protocol or FOUNDATION Fieldbus ITK 6.0.1 compliant<br>All transmitters, irrespective of protocol have polarity insensitive connection.   |                        |                     |                        |                    |                      |  |                       |               |               |                      |                        |                        |
| <b>Output Failure Modes</b>  | <table> <thead> <tr> <th></th> <th>Honeywell Standard:</th> <th>NAMUR NE 43</th> </tr> </thead> <tbody> <tr> <td><b>Compliance:</b></td> <td></td> <td></td> </tr> <tr> <td><b>Normal Limits:</b></td> <td>3.8 – 20.8 mA</td> <td>3.8 – 20.5 mA</td> </tr> <tr> <td><b>Failure Mode:</b></td> <td>≤ 3.6 mA and ≥ 21.0 mA</td> <td>≤ 3.6 mA and ≥ 21.0 mA</td> </tr> </tbody> </table>  |                        | Honeywell Standard: | NAMUR NE 43            | <b>Compliance:</b> |                      |  | <b>Normal Limits:</b> | 3.8 – 20.8 mA | 3.8 – 20.5 mA | <b>Failure Mode:</b> | ≤ 3.6 mA and ≥ 21.0 mA | ≤ 3.6 mA and ≥ 21.0 mA |
|  | Honeywell Standard:  | NAMUR NE 43            |                     |                        |                    |                      |  |                       |               |               |                      |                        |                        |
| <b>Compliance:</b>   |  |                        |                     |                        |                    |                      |  |                       |               |               |                      |                        |                        |
| <b>Normal Limits:</b>  | 3.8 – 20.8 mA  | 3.8 – 20.5 mA          |                     |                        |                    |                      |  |                       |               |               |                      |                        |                        |
| <b>Failure Mode:</b>   | ≤ 3.6 mA and ≥ 21.0 mA   | ≤ 3.6 mA and ≥ 21.0 mA |                     |                        |                    |                      |  |                       |               |               |                      |                        |                        |
| <b>Supply Voltage Effect</b>   | 0.005% span per volt.  |                        |                     |                        |                    |                      |  |                       |               |               |                      |                        |                        |
| <b>Transmitter Turn on Time</b><br>(includes power up & test algorithms) | HART or DE: 5.0 sec.   |                        |                     |                        |                    |                      |  |                       |               |               |                      |                        |                        |
| <b>Response Time (DP)</b><br>(delay + time constant)                     | <b>DE/HART Analog Output:</b> 144mS  |                        |                     |                        |                    |                      |  |                       |               |               |                      |                        |                        |
| <b>Damping Time Constant</b>   | <b>HART DP/SP:</b> Adjustable from 0 to 32 seconds in 0.1 increments. <b>Default:</b> 0.50 seconds<br><b>HART Temperature:</b> Damping limit is 0 to 102<br><b>HART FLOW:</b> Damping limit is 0 to 100<br><b>DE DP/SP:</b> 0, 0.16, 0.32, 0.48, 1, 2, 4, 8, 16, 32 seconds. <b>Default:</b> 0.48 seconds<br><b>DE for Temperature PV:</b> Damping time 0, 0.3, 0.7, 1.5, 3.1, 6.3, 12.7, 25.5, 51.1, 102.3<br><b>DE for Flow PV:</b> Damping time 0, 0.50, 1, 2, 3, 4, 5, 10, 50, 100 |                        |                     |                        |                    |                      |  |                       |               |               |                      |                        |                        |
| <b>Vibration Effect</b><br>SMA845, SMG870                                | Less than +/- 0.1% of URL w/o damping<br>Per IEC60770-1 field or pipeline, high vibration level (10-2000Hz: 0.21 displacement/3g max acceleration)   |                        |                     |                        |                    |                      |  |                       |               |               |                      |                        |                        |
| <b>Electromagnetic Compatibility</b>                                     | EN 61326-1   |                        |                     |                        |                    |                      |  |                       |               |               |                      |                        |                        |
| <b>Isolation</b>   | 2000 Vdc (1400Vrms) Galvanic Isolation between inputs and outputs  |                        |                     |                        |                    |                      |  |                       |               |               |                      |                        |                        |
| <b>Maximum Lead Wire Resistance</b>                                      | Thermocouples: 50 ohms/leg<br>Pt100, Pt200, Pt500 and Pt1000 RTDs: 50 ohms/leg<br>Pt25 RTD: 10 ohms per leg  |                        |                     |                        |                    |                      |  |                       |               |               |                      |                        |                        |
| <b>Ambient Temperature Effect</b>  | <b>Digital Accuracy:</b><br>For RTD Inputs, 0.0015°C/°C<br>For T/C Inputs: 0.005°C/°C  |                        |                     |                        |                    |                      |  |                       |               |               |                      |                        |                        |
| <b>Temperature Sensor Burnout</b>  | Burnout detection is user selectable. Upscale or down scale with critical status message.<br>For RTD type inputs; broken wire/wires will be indicated  |                        |                     |                        |                    |                      |  |                       |               |               |                      |                        |                        |
| <b>Lightning Protection Option</b>                                       | <b>Leakage Current:</b> 10uA max @ 42.4VDC 93C<br><b>Impulse rating:</b> <table> <tbody> <tr> <td>8/20uS</td> <td>5000A (&gt;10 strikes)</td> <td>10000A (1 strike min.)</td> </tr> <tr> <td>10/1000uS</td> <td>200A (&gt; 300 strikes)</td> <td></td> </tr> </tbody> </table>   | 8/20uS                 | 5000A (>10 strikes) | 10000A (1 strike min.) | 10/1000uS          | 200A (> 300 strikes) |  |                       |               |               |                      |                        |                        |
| 8/20uS   | 5000A (>10 strikes)  | 10000A (1 strike min.) |                     |                        |                    |                      |  |                       |               |               |                      |                        |                        |
| 10/1000uS  | 200A (> 300 strikes)   |                        |                     |                        |                    |                      |  |                       |               |               |                      |                        |                        |

## Materials Specifications

(See model selection guide for availability/restrictions with various models)

| Parameter   | Description   |
|---|---|
| <b>Barrier Diaphragms Material</b>                | 316L SS, Hastelloy® C-276 <sup>2</sup> , Monel® 400 <sup>3</sup> , Tantalum, Gold-plated 316L SS, Gold-plated Hastelloy® C-276, Gold-plated Monel® 400  |
| <b>Process Head Material</b>                      | 316 SS <sup>4</sup> , Carbon Steel (Zinc-plated) <sup>5</sup> , Hastelloy C-276 <sup>6</sup> , Monel 400 <sup>7</sup>   |
| <b>Vent/Drain Valves &amp; Plugs</b> <sup>1</sup> | 316 SS <sup>4</sup> , Hastelloy C-276 <sup>2</sup> , Monel 400 <sup>7</sup>   |
| <b>Head Gaskets</b>                               | Glass-filled PTFE standard. Viton® and graphite are optional.   |
| <b>Meter Body Bolting</b>                         | Carbon Steel (Zinc plated) standard. Options include 316 SS, NACE A286 SS bolts, Monel K500, Super Duplex and B7M.  |
| <b>Optional Adapter Flange and Bolts</b>          | Adapter Flange materials include 316 SS, Hastelloy C-276 and Monel 400. Bolt material for flanges is dependent on process head bolts material chosen. Standard adaptor o-ring material is glass-filled PTFE. Viton and graphite are optional. |
| <b>Mounting Bracket</b>                           | Carbon Steel (Zinc-plated) , 304 Stainless Steel or 316 Stainless Steel   |
| <b>Fill Fluid</b>                                 | Silicone Oil DC200, Silicone Oil 704, NEOBEE® M-20 or CTFE (Chlorotrifluoroethylene).   |
| <b>Electronic Housing</b>                         | Pure Polyester Powder Coated Low Copper (<0.4%)-Aluminum. Meets Type 4X, IP66, & IP67. All stainless steel housing is optional.   |
| <b>Mounting</b>                                   | Can be mounted in virtually any position using the standard mounting bracket. Bracket is designed to mount on 2-inch (50 mm) vertical or horizontal pipe. See <a href="#">Figure 4</a> .  |
| <b>Process Connections</b>                        | ¼"- NPT or ½"- NPT with adapter (meets DIN requirements)  |
| <b>Wiring</b>                                     | Accepts up to 16 AWG (1.5 mm diameter).   |
| <b>Dimensions</b>                                 | See <a href="#">Figure 5</a> .  |
| <b>Net Weight</b>                                 | 8.3 pounds (3.8 Kg). With Aluminum Housing  |

<sup>1</sup> Vent/Drains are sealed with Teflon®

<sup>2</sup> Hastelloy C-276 or UNS N10276

<sup>3</sup> Monel 400 or UNS N04400

<sup>4</sup> Supplied as 316 SS or as Grade CF8M, the casting equivalent of 316 SS.

<sup>5</sup> Carbon Steel heads are zinc-plated and not recommended for water service due to hydrogen migration. For that service, use 316 stainless steel wetted Process Heads.

<sup>6</sup> Hastelloy C-276 or UNS N10276. Supplied as indicated or as Grade CW12MW, the casting equivalent of Hastelloy C-276

<sup>7</sup> Monel 400 or UNS N04400. Supplied as indicated or as Grade M30C, the casting equivalent of Monel 400

## Communications Protocols & Diagnostics

### HART Protocol

**Version:**

HART 7

**Power Supply**

Voltage: 10.8 Vdc to 42.4 Vdc at terminals

Load: Maximum 1440 ohms See [Figure 2](#).

Minimum Load: 0 ohms. (For handheld communications a minimum load of 250 ohms is required)

### Standard Diagnostics

SMV 800 top level diagnostics are reported as either critical or non-critical and readable via the DD/DTM tools or integral display as shown below.

| Critical Diagnostics  |   |
|---|---|
| HART DD/DTM Tools   | Display   |
| <ul style="list-style-type: none"> <li>• Sensor Critical Fault</li> </ul>   | <ul style="list-style-type: none"> <li>• Meter Body and/or</li> <li>• Meter Body Comm and/or</li> <li>• Temp Sense Board and/or</li> <li>• Temp Input and/or</li> <li>• Temp Sensor Comm</li> </ul> |
| <ul style="list-style-type: none"> <li>• SIL Diag Failure or</li> <li>• msp vcc fault and/or</li> <li>• Config Data Corrupt</li> <li>• DAC Failure</li> </ul> | <ul style="list-style-type: none"> <li>• Comm Module</li> </ul>   |
| <ul style="list-style-type: none"> <li>• DAC Failure</li> </ul>   | <ul style="list-style-type: none"> <li>• Comm Module Temp</li> </ul>  |
| <ul style="list-style-type: none"> <li>• msp vcc fault</li> </ul>   | <ul style="list-style-type: none"> <li>• msp vcc fault</li> </ul>   |

### Honeywell Digitally Enhanced (DE)

DE is a Honeywell proprietary protocol which provides multivariable DE communications between Honeywell DE enabled field devices and Hosts.

**Power Supply**

Voltage: 15 Vdc to 42.4 Vdc at terminals

Load: Maximum 900 ohms See [Figure 2](#).

| Non-critical Diagnostics  |  |
|---|--|
| HART DD/DTM Tools   | Display  |
| <ul style="list-style-type: none"> <li>• Local Display</li> </ul>                   | <ul style="list-style-type: none"> <li>• Display Setup</li> </ul>  |
| <ul style="list-style-type: none"> <li>• Fixed Current Mode</li> </ul>              | <ul style="list-style-type: none"> <li>• Analog Out Mode</li> </ul>  |
| <ul style="list-style-type: none"> <li>• Comm Sec NC Fault</li> </ul>               | N/A  |
| <ul style="list-style-type: none"> <li>• Sensing Sec NC Fault</li> </ul>            | <ul style="list-style-type: none"> <li>• Temp cal Correct</li> <li>• DP Zero Correct and/or</li> <li>• DP Span Correct and/or</li> <li>• Meter Body Input</li> </ul>       |
| <ul style="list-style-type: none"> <li>• Sensor Over Temperature</li> </ul>         | <ul style="list-style-type: none"> <li>• Temp Module Temp and/or</li> <li>• Meter Body Temp</li> </ul>   |
| <ul style="list-style-type: none"> <li>• PV Out Of Range</li> </ul>                 | <ul style="list-style-type: none"> <li>• PV Out Of Range</li> </ul>  |
| <ul style="list-style-type: none"> <li>• No Fact Calib</li> </ul>                   | <ul style="list-style-type: none"> <li>• Pressure Fac Cal and/or</li> <li>• Temp Fac Cal</li> </ul>  |
| <ul style="list-style-type: none"> <li>• No DAC Compensation</li> </ul>             | <ul style="list-style-type: none"> <li>• DAC Temp Comp</li> </ul>  |
| <ul style="list-style-type: none"> <li>• N/A</li> </ul>                             | <ul style="list-style-type: none"> <li>• Temp Cal Correct</li> </ul>   |
| <ul style="list-style-type: none"> <li>• LRV Set Err. Zero Config Button</li> </ul> | N/A  |
| <ul style="list-style-type: none"> <li>• URV Set Err. Span Config Button</li> </ul> | N/A  |
| <ul style="list-style-type: none"> <li>• CJ Out of Limit</li> </ul>                 | <ul style="list-style-type: none"> <li>• CJ Range</li> </ul>   |
| <ul style="list-style-type: none"> <li>• AO Out of Range</li> </ul>                 | N/A  |
| <ul style="list-style-type: none"> <li>• Sensor Input Open</li> </ul>               | <ul style="list-style-type: none"> <li>• Temp Input and/or</li> <li>• Temp Input TB6</li> </ul>  |
| <ul style="list-style-type: none"> <li>• Loop Current Noise</li> </ul>              | N/A  |
| <ul style="list-style-type: none"> <li>• Sensor Unreliable Comm</li> </ul>          | <ul style="list-style-type: none"> <li>• Meter Body Comm and/or</li> <li>• Temp Comm</li> </ul>  |
| <ul style="list-style-type: none"> <li>• Tamper Alarm</li> </ul>                    | N/A  |
| <ul style="list-style-type: none"> <li>• No DAC Calibration</li> </ul>              | N/A  |
| <ul style="list-style-type: none"> <li>• Low Supply Voltage</li> </ul>              | <ul style="list-style-type: none"> <li>• Supply Voltage</li> </ul>   |
| <ul style="list-style-type: none"> <li>• Flow Calculation Details</li> </ul>        | <ul style="list-style-type: none"> <li>• Flow Divide by 0 and/or</li> <li>• Flow Sqrt of Neg and/or</li> <li>• Flow Direction and/or</li> <li>• Flow SP/PT Comp</li> </ul> |
| <ul style="list-style-type: none"> <li>• DP/SP/PT/FLOW Simulation Mode</li> </ul>   | <ul style="list-style-type: none"> <li>• DP Simulation and/or</li> <li>• SP Simulation and/or</li> <li>• PT Simulation and/or</li> <li>• Flow Simulation</li> </ul>        |
| <ul style="list-style-type: none"> <li>• Sensor health Warning</li> </ul>           | N/A  |
| <ul style="list-style-type: none"> <li>• Sensor In Low Power Mode</li> </ul>        | N/A  |

### Other Certification Options

**Materials**

- NACE MRO175, MRO103, ISO15156

## Hazardous Location Approval Certifications:

| MSG CODE | AGENCY        | TYPE OF PROTECTION  | Electrical Parameters | Ambient Temperature                                |  |
|----------|---------------|---|-----------------------|--|--|
| A        | FM Approvals™ | <b>Explosion proof:</b><br>Class I, Division 1, Groups A, B, C, D<br><b>Dust Ignition Proof:</b><br>Class II, Division 1, Groups E, F, G;<br>Suitable for Division 1, Class III;<br>Class I, Zone 0/1, AEx d IIC T6..T5 Ga/Gb<br>Class II, Zone 21, AEx tb IIIC T 95°C Db   | Note 1                | T5: -50 °C to 85°C<br>T6: -50 °C to 65°C           |  |
|          |               | <b>Intrinsically Safe:</b><br>Class I, II, III, Division 1, Groups A, B, C, D, E, F, G<br>Class I Zone 0 AEx ia IIC T4 Ga   | Note 2                | T4: -50°C to 70°C                                  |  |
|          |               | <b>Non-Incendive and Intrinsically Safe:</b><br>Class I, Division 2, Groups A, B, C, D<br>Class I Zone 2 AEx nA IIC T4 Gc   | Note 1                | T4: -50°C to 85°C                                  |  |
|          |               | <b>Enclosure:</b> Type 4X/ IP66/ IP67   |                       |  |  |
|          |               | <b>Standards:</b> FM 3600:2011; ANSI/ ISA 60079-0: 2013; FM 3615:2006; ANSI/ ISA 60079-1 : 2013; FM 3616 : 2011 ; ANSI/ ISA 60079-31 : 2013; FM 3610:2015; ANSI/ ISA 60079-11 : 2012; FM 3810 : 2005 ; ANSI/ ISA 60079-26 : 2011; FM 3611:2004; ANSI/ ISA 60079-15 : 2012 ; FM 3810 : 2005; ANSI/ ISA 61010-1: 2004;NEMA 250 : 2003 ; ANSI/ IEC 60529 : 2004  |                       |  |  |
| B        | CSA-Canada    | <b>Explosion proof:</b><br>Class I, Division 1, Groups A, B, C, D<br><b>Dust Ignition Proof:</b><br>Class II, III, Division 1, Groups E, F, G<br>Suitable for Division 1, Class III;<br>Zone 0/1, Ex d IIC T6..T5 Ga/Gb<br>Ex tb IIIC T 95°C Db   | Note 1                | T5: -50 °C to 85°C<br>T6: -50 °C to 65 °C          |  |
|          |               | <b>Intrinsically Safe:</b><br>Class I, II, III, Division 1, Groups A, B, C, D, E, F, G;<br><br>Ex ia IIC T4 Ga<br>FISCO Field Device (Only for FF Option)<br>Ex ia IIC T4 Ga  | Note 2                | T4: -50°C to 70°C<br><br>T4: -50°C to 45°C (FISCO) |  |
|          |               | <b>Non-Incendive and Intrinsically Safe:</b><br>Class I, Division 2, Groups A, B, C, D<br>Ex nA IIC T4 Gc   | Note 1                | T4: -50°C to 85°C                                  |  |
|          |               | <b>Enclosure:</b> Type 4X/ IP66/ IP67   |                       |  |  |
|          |               | <b>Standards:</b> CSA C22.2 No 0: 2010; CSA C22.2 No. 0-M91; CSA C22.2 No 25: 1966; CSA C22.2 No 30M; 1986; CSA C22.2 No. 142M: 1987; CAN/ CSA-C22.2 No.157: 1992; CSA C22.2 No 213M: 1987; CSA C22.2 No 60529: 2005; CSA C22.2 No 60079-0: 2011; CSA C22.2 No 60079-1: 2011; CSA C22.2 60079-11: 2011; CSA C22.2 60079-15: 2012; CSA C22.2 60079-31: 2012; ISA 12.12.01: 2010; ANSI/ ISA 60079-0: 2009; ANSI/ ISA 60079-1: 2012; ANSI/ ISA 60079-11: 2011; ANSI/ ISA 60079-15: 2009; ANSI/ ISA 60079-26 : 2011; ANSI/ ISA 60079-31 : 2012; ISA 60079-27: R2011; UL 913: ed 6; UL 916: 1998 |                       |  |  |

|   |                        |   |        |   |
|---|------------------------|---|--------|---|
| C | ATEX                   | <b>Flameproof:</b><br>Sira 15ATEX2039X<br>II 1/2 G Ex d IIC T6..T5 Ga/Gb<br>II 2 D Ex tb IIIC T 95°C..T125°C Db   | Note 1 | T5/ T95°C: -50 °C to 85°C<br>T6: -50 °C to 65°C   |
|   |                        | <b>Intrinsically Safe:</b><br>Sira 15ATEX2039X<br>II 1 G Ex ia IIC T4 Ga  | Note 2 | T4: -50°C to 70°C                                 |
|   |                        | <b>Non Sparking and Intrinsically Safe:</b><br>Sira12ATEX4234X<br>II 3 G Ex nA IIC T4 Gc  | Note 1 | T4: -50°C to 85°C                                 |
|   |                        | <b>Standards:</b> EN 60079-0: 2012+A11: 2013; EN 60079-1 : 2007; EN 60079-11 : 2012; EN 60079-31 : 2014 EN 60079-26 : 2007; EN 60529 : 2000 + A1; EN 60079-15 : 2010  |        |   |
|   |                        | <b>Enclosure:</b> IP66/ IP67  |        |   |
| D | IECEX                  | <b>Intrinsically Safe:</b><br>IECEX SIR 15.0022X<br>Ex ia IIC T4 Ga   | Note 2 | T4: -50°C to 70°C                                 |
|   |                        | <b>Non Sparking:</b><br>IECEX SIR 15.0022X<br>Ex nA IIC T4 Gc   | Note 1 | T4: -50°C to 85°C                                 |
|   |                        | <b>Flameproof:</b><br>Ex d IIC T6..T5 Ga/Gb<br>Ex tb IIIC T 95°C..125 °C Db   | Note 1 | T5: -50 °C to 85°C<br>T6: -50 °C to 65°C          |
|   |                        | <b>Enclosure:</b> IP66/ IP67  |        |   |
|   |                        | <b>Standards:</b> IEC 60079-0: 2011; IEC 60079-1 : 2007; IEC 60079-11: 2011; IEC 60079-15 : 2011; IEC 60079-31: 2013; IEC 60079-26: 2006  |        |   |
| E | SAEx<br>(South Africa) | <b>Intrinsically Safe:</b><br>Ex ia IIC T4 Ga<br>FISCO Field Device (Only for FF Option)<br>Ex ia IIC T4 Ga   | Note 2 | T4: -50°C to 70°C<br>T4: -50°C to 45°C<br>(FISCO) |
|   |                        | <b>Non Sparking:</b><br>Ex nA IIC Gc  | Note 1 | T4: -50°C to 85°C                                 |
|   |                        | <b>Flameproof:</b><br>Ex d IIC T6..T5 Ga/Gb<br>Ex tb IIIC T95°C..T125 °C Db   | Note 1 | T5: -50 °C to 85°C<br>T6: -50 °C to 65°C          |
|   |                        | <b>Enclosure:</b> IP66/ IP67  |        |   |
| F | INMETRO<br>(Brazil)    | <b>Intrinsically Safe:</b><br>Ex ia IIC Ga  | Note 2 | T4: -50°C to 70°C                                 |
|   |                        | <b>Non Sparking:</b><br>Ex nA IIC T4 Gc   | Note 1 | T4: -50°C to 85°C                                 |
|   |                        | <b>Flameproof:</b><br>Ex d IIC T6..T5 Ga/Gb<br>Ex tb IIIC T 95°C..T125 °C Db  | Note 1 | T5: -50 °C to 85°C<br>T6: -50 °C to 65°C          |
|   |                        | <b>Enclosure:</b> IP66/ IP67  |        |   |
|   |                        | <b>Standards:</b> ABNT NBR IEC 60079-0:2013 (IEC 60079-0:2011); ABNT NBR IEC 60079-1:2009 (IEC 60079-1:2007); ABNT NBR IEC 60079-11:2013 (IEC 60079-11:2011); ABNT NBR IEC 60079-15:2012 (IEC 60079-15:2010); ABNT NBR IEC 60079-26:2008 (IEC 60079-26:2006); ABNT NBR IEC 60079-31:2014 (IEC 60079-31:2013). |        |   |

|   |                  |  |        |  |
|---|------------------|--|--------|--|
| G | NEPSI<br>(CHINA) | <b>Intrinsically Safe:</b><br>Ex ia IIC T4 Ga                                  | Note 2 | T4: -50°C to 70°C                        |
|   |                  | <b>Non Sparking:</b><br>Ex nA IIC T4 Gc  | Note 1 | T4: -50°C to 85°C                        |
|   |                  | <b>Flameproof:</b><br>Ex d IIC T6..T5 Ga/Gb<br>Ex tb IIIC Db T95°C..T125 °C Db | Note 1 | T5: -50 °C to 85°C<br>T6: -50 °C to 65°C |
|   |                  | <b>Enclosure:</b> IP66/ IP67   |        |  |
| H | KOSHA<br>(Korea) | <b>Flameproof:</b><br>Ex d IIC T6..T5<br>Ex tD A21 T 95°C..T125 °C             | Note 1 | T5: -50 °C to 85°C<br>T6: -50 °C to 65°C |
|   |                  | <b>Intrinsically Safe:</b><br>Ex ia IIC Ga                                     | Note 2 | T4: -50°C to 70°C                        |
| I | EAC Ex           | Ex d IIC T6..T5 Ga/Gb<br>Ex tb IIIC T95°C Db                                   | Note 1 | T5: -50 °C to 85°C<br>T6: -50 °C to 65°C |
|   |                  | <b>Intrinsically Safe:</b><br>Ex ia IIC T4 Ga                                  | Note 2 | T4: -50 °C to 70°C                       |
|   |                  | <b>Non Sparking:</b><br>2 Ex nA IIC T4 Gc                                      | Note 1 | T4: -50°C to 85°C                        |
|   |                  | <b>Enclosure :</b> IP 66/67  |        |  |

**Notes**

**1. Operating Parameters:**

Voltage= 11 to 42 V

Current= 4-20 mA Normal (3.8 – 23 mA Faults)

**2. Intrinsically Safe Entity Parameters**

Vmax= Ui= 30 V

I<sub>max</sub>= Ii= 225mA

Ci=4 nF

Li= 0 uH

Pi= 0.9 W

**Temperature Sensor Wiring Diagram**

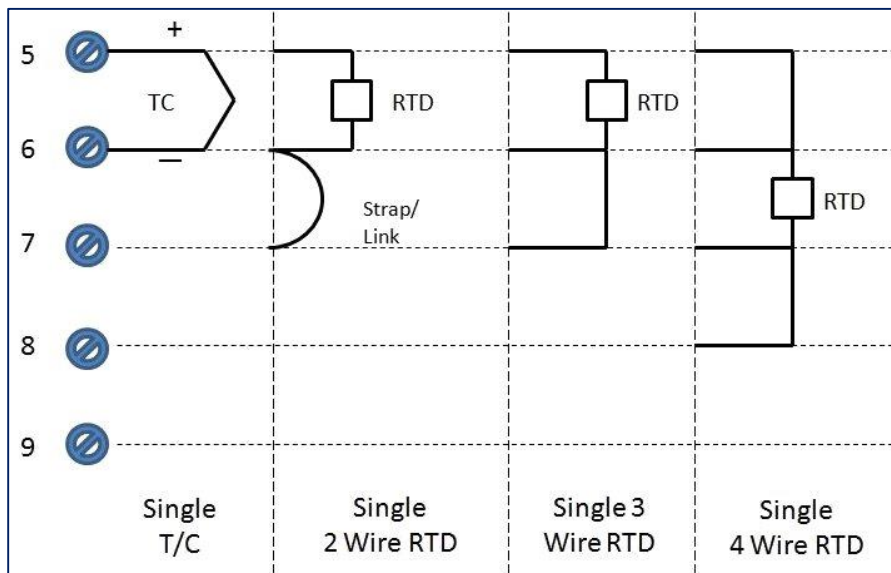

**Figure 3 – Temperature sensor Wiring Diagram**

## Mounting & Dimensional Drawings

Reference Dimensions:  $\frac{\text{millimeters}}{\text{inches}}$

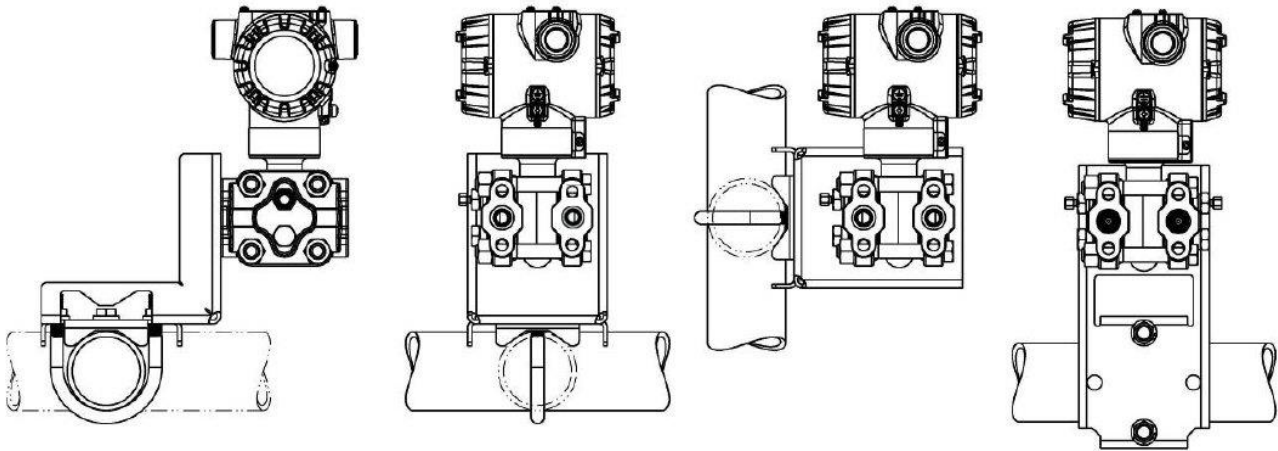

Figure 4 – Mounting Configurations

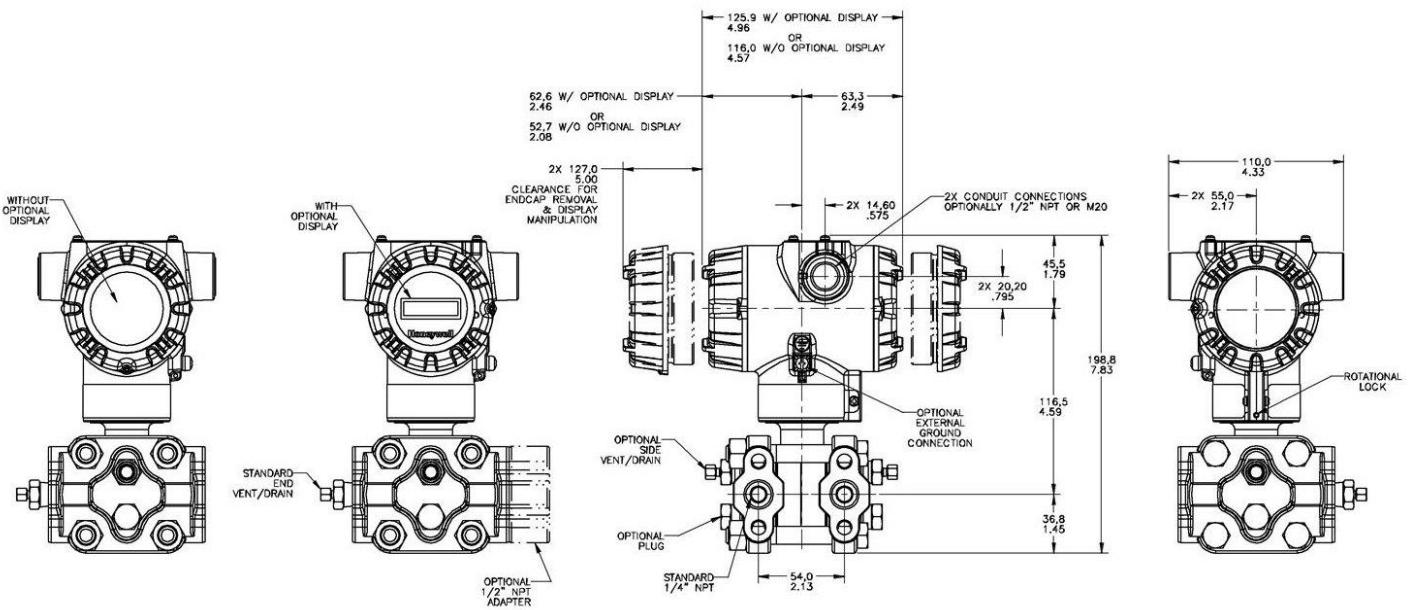
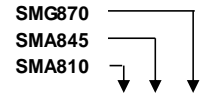
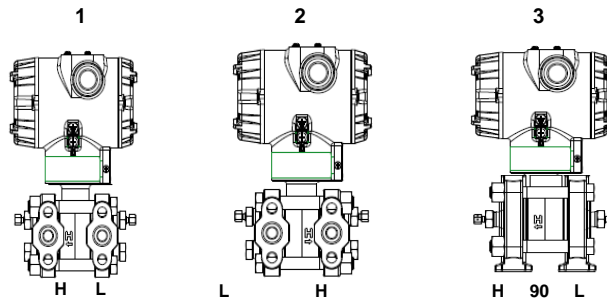

Figure 5 – Typical mounting dimensions for reference





| TABLE IV                 |             | Meter Body & Connection Orientation   |
|--------------------------|-------------|---|
| Head/Connect Orientation | Standard    | High Side Left, Low Side Right <sup>2</sup> / Std Head Orientation          |
|                          | Reversed    | Low Side Left, High Side Right <sup>2</sup> / Std Head Orientation          |
|                          | 90/Standard | High Side Left, Low Side Right <sup>2</sup> / 90 <sup>0</sup> Head Rotation |

|   |   |   |   |
|---|---|---|---|
| 1 | * | * | * |
| 2 | * | * | * |
| 3 | h | h | h |

| TABLE V   |   | Agency Approvals (see data sheet for Approval Code Details) |
|-----------|---|---|
| Approvals | No Approvals Required   |   |
|           | FM Explosion proof, Intrinsically Safe, Non-incendive, & Dustproof                        |   |
|           | CSA Explosion proof, Intrinsically Safe, Non-incendive, & Dustproof                       |   |
|           | ATEX Explosion proof, Intrinsically Safe & Non-incendive                                  |   |
|           | IECEX Explosion proof, Intrinsically Safe & Non-incendive                                 |   |
|           | SAEx Explosion proof, Intrinsically Safe & Non-incendive                                  |   |
|           | INMETRO Explosion proof, Intrinsically Safe & Non-incendive                               |   |
|           | NEPSI Explosion proof, Intrinsically Safe & Non-incendive                                 |   |
|           | KOSHA Explosion proof, Intrinsically Safe & Non-incendive                                 |   |
|           | EAC Customs Union(Russia,Belarus,Kazakhstan) Ex Approval, Flame proof, Intrinsically Safe |   |

|   |   |   |   |
|---|---|---|---|
| 0 | * | * | * |
| A | * | * | * |
| B | * | * | * |
| C | * | * | * |
| D | * | * | * |
| E | * | * | * |
| F | * | * | * |
| G | * | * | * |
| H | * | * | * |
| I | * | * | * |

| TABLE VI   |                                  |                                 |                              | TRANSMITTER ELECTRONICS SELECTIONS |                      |  |  |
|--|----------------------------------|---------------------------------|------------------------------|------------------------------------|----------------------|--|--|
| a. Electronic Housing Material & Connection Type | Material                         |                                 | Connection                   |                                    | Lightning Protection |  |  |
|  | Polyester Powder Coated Aluminum |                                 | 1/2 NPT                      |                                    | None                 |  |  |
|  |                                  |                                 | M20                          |                                    | None                 |  |  |
|  | 316 Stainless Steel (Grade CF8M) |                                 | 1/2 NPT                      |                                    | Yes                  |  |  |
|  |                                  |                                 | M20                          |                                    | Yes                  |  |  |
|  |                                  |                                 | 1/2 NPT                      |                                    | None                 |  |  |
| M20  |                                  |                                 | None                         |                                    |                      |  |  |
| 1/2 NPT  |                                  | Yes                             |                              |                                    |                      |  |  |
| M20  |                                  | Yes                             |                              |                                    |                      |  |  |
| b. Output/ Protocol                              | Analog Output                    |                                 | Digital Protocol             |                                    |                      |  |  |
|  | 4-20mA dc<br>4-20mA dc           |                                 | HART Protocol<br>DE Protocol |                                    |                      |  |  |
| c. Customer Interface Selections                 | Indicator                        | Ext Zero, Span & Config Buttons |                              | Languages                          |                      |  |  |
|  | None                             | None                            |                              | None                               |                      |  |  |
|  | None                             | Yes (Zero/Span Only)            |                              | None                               |                      |  |  |
|  | Advanced                         | None                            |                              | EN,DE,FR,IT,ES,RU,TU               |                      |  |  |
|  | Advanced                         | Yes                             |                              | EN,DE,FR,IT,ES,RU,TU               |                      |  |  |
|  | Advanced                         | None                            |                              | EN, CH, JP                         |                      |  |  |
| Advanced   | Yes                              |                                 | EN, CH, JP                   |                                    |                      |  |  |

|     |   |   |   |
|-----|---|---|---|
| A__ | * | * | * |
| B__ | * | * | * |
| C__ | * | * | * |
| D__ | * | * | * |
| E__ | * | * | * |
| F__ | * | * | * |
| G__ | * | * | * |
| H__ | * | * | * |

|     |   |   |   |
|-----|---|---|---|
| _H_ | * | * | * |
| _D_ | u | u | u |

|       |   |   |   |
|-------|---|---|---|
| _ _ 0 | * | * | * |
| _ _ A | * | * | * |
| _ _ D | * | * | * |
| _ _ E | * | * | * |
| _ _ H | * | * | * |
| _ _ J | * | * | * |

| TABLE VII  |   |                 |                                       | CONFIGURATION SELECTIONS |  |  |  |
|--|---|-----------------|---------------------------------------|--------------------------|--|--|--|
| a. Application Software                            | Diagnostics   |                 |                                       |                          |  |  |  |
|  | Standard Diagnostics  |                 |                                       |                          |  |  |  |
| b. Output Limit, Failsafe & Write Protect Settings | Write Protect   | Fail Mode       | High & Low Output Limits <sup>3</sup> |                          |  |  |  |
|  | Disabled  | High> 21.0mA dc | Honeywell Std (3.8 - 20.8 mA dc)      |                          |  |  |  |
|  | Disabled  | Low< 3.6mA dc   | Honeywell Std (3.8 - 20.8 mA dc)      |                          |  |  |  |
|  | Enabled   | High> 21.0mA dc | Honeywell Std (3.8 - 20.8 mA dc)      |                          |  |  |  |
|  | Enabled   | Low< 3.6mA dc   | Honeywell Std (3.8 - 20.8 mA dc)      |                          |  |  |  |
| c. General Configuration                           | Factory Standard<br>Custom Configuration (Unit Data Required from customer) |                 |                                       |                          |  |  |  |

|     |   |   |   |
|-----|---|---|---|
| 1__ | * | * | * |
|-----|---|---|---|

|       |   |   |   |
|-------|---|---|---|
| _ 1 _ | * | * | * |
| _ 2 _ | * | * | * |
| _ 3 _ | * | * | * |
| _ 4 _ | * | * | * |
| _ _ S | * | * | * |
| _ _ C | * | * | * |

<sup>2</sup> Left side/Right side as viewed from the customer connection perspective

<sup>3</sup> NAMUR Output Limits 3.8 - 20.5mA dc can be configured by the customer or select custom configuration Table Vc

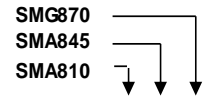

| TABLE VIII PV1,PV2 & PV3 CALIBRATION & ACCURACY SELECTIONS |          |   |                                |
|--|----------|---|--------------------------------|
|  | Accuracy | Calibrated Range                        | # of Calibrations              |
| a. Accuracy and Calibration                                | Standard | PV1,PV2&PV3 Factory Std                 | PV1,PV2&PV3 Single Calibration |
|  |          | PV1,PV2&PV3 Custom (Unit Data Required) | PV1,PV2&PV3 Single Calibration |
|  |          | PV1,PV2&PV3 Custom (Unit Data Required) | PV1&PV2 Dual Calibration       |
|  |          | PV1,PV2&PV3 Custom (Unit Data Required) | PV1&PV2 Triple Calibration     |

|   |   |   |   |
|---|---|---|---|
| A | * | * | * |
| B | * | * | * |
| C | * | * | * |
| D | * | * | * |

| TABLE IX ACCESSORY SELECTIONS           |  |              |
|---|--|--------------|
|   | Bracket Type   | Material     |
| a. Mounting Bracket                     | None   | None         |
|   | Angle Bracket  | Carbon Steel |
|   | Angle Bracket  | 304 SS       |
|   | Angle Bracket  | 316 SS       |
|   | Flat Bracket   | Carbon Steel |
|   | Flat Bracket   | 304 SS       |
|   | Flat Bracket   | 316 SS       |
| b. Customer Tag                         | Customer Tag Type  |              |
|   | No customer tag  |              |
|   | One Wired Stainless Steel Tag (Up to 4 lines 26 char/line)<br>Two Wired Stainless Steel Tag (Up to 4 lines 26 char/line)           |              |
| c. Unassembled Conduit Plugs & Adapters | Unassembled Conduit Plugs & Adapters   |              |
|   | No Conduit Plugs or Adapters Required  |              |
|   | 1/2 NPT Male to 3/4 NPT Female 316 SS Certified Conduit Adapter  |              |
|   | 1/2 NPT 316 SS Certified Conduit Plug  |              |
|   | M20 316 SS Certified Conduit Plug  |              |
|   | Minifast® 4 pin (1/2 NPT) (not suitable for X-Proof applications)<br>Minifast® 4 pin (M20) (not suitable for X-Proof applications) |              |

|       |   |   |   |
|-------|---|---|---|
| 0 ___ | * | * | * |
| 1 ___ | * | * | * |
| 2 ___ | * | * | * |
| 3 ___ | * | * | * |
| 5 ___ | * | * | * |
| 6 ___ | * | * | * |
| 7 ___ | * | * | * |

|         |   |   |   |
|---------|---|---|---|
| _ 0 _ _ | * | * | * |
| _ 1 _ _ | * | * | * |
| _ 2 _ _ | * | * | * |

|        |   |   |   |
|--------|---|---|---|
| _ _ A0 | * | * | * |
| _ _ A2 | n | n | n |
| _ _ A6 | n | n | n |
| _ _ A7 | m | m | m |
| _ _ A8 | n | n | n |
| _ _ A9 | m | m | m |

| TABLE X OTHER Certifications & Options: (String in sequence comma delimited (XX, XX, XX,...)) |   |
|---|---|
| Certifications & Warranty   | None - No additional options  |
|   | NACE MR0175; MR0103; ISO15156 (FC33338) Process wetted parts only           |
|   | NACE MR0175; MR0103; ISO15156 (FC33339) Process wetted and non-wetted parts |
|   | EN10204 Type 3.1 Material Traceability (FC33341)                            |
|   | Certificate of Conformance (F3391)  |
|   | Calibration Test Report & Certificate of Conformance (F3399)                |
|   | Certificate of Origin (F0195)   |
|   | FMEDA (SIL 2/3) Certification (FC33337)                                     |
|   | Over-Pressure Leak Test Certificate (1.5X MAWP) (F3392)                     |
|   | Cert Clean for O <sub>2</sub> or CL <sub>2</sub> service per ASTM G93       |
|   | PMI Certification <sup>1</sup>  |
|   | Extended Warranty Additional 1 year   |
|   | Extended Warranty Additional 2 years  |
|   | Extended Warranty Additional 3 years  |
|   | Extended Warranty Additional 4 years  |
| Extended Warranty Additional 15 years   |   |

|    |   |   |   |
|----|---|---|---|
| 00 | * | * | * |
| FG | * | * | * |
| F7 | c | c | c |
| FX | * | * | * |
| F3 | * | * | * |
| F1 | * | * | * |
| F5 | * | * | * |
| FE | j | j | j |
| TP | * | * | * |
| OX | e | e | e |
| PM | * | * | * |
| 01 | * | * | * |
| 02 | * | * | * |
| 03 | * | * | * |
| 04 | * | * | * |
| 15 | * | * | * |

| TABLE XI Manufacturing Specials |                        |
|---------------------------------|------------------------|
| Factory                         | Factory Identification |

|      |   |   |   |
|------|---|---|---|
| 0000 | * | * | * |
|------|---|---|---|

**MODEL RESTRICTIONS**

| Restriction Letter | Available Only with                    |              | Not Available with |                            |
|--------------------|--|--------------|--------------------|----------------------------|
|                    | Table                                  | Selection(s) | Table              | Selection(s)               |
| a                  |  |              | X                  | F7, FG                     |
| c                  | III d                                  | N, K, D, B   | III a              | C, D, 3, G, H, 6, K, L, 8  |
| e                  | III b                                  | 2            |                    |                            |
| h                  |  |              | III e              | 4, 5, 6                    |
|                    |  |              | IX a               | 1, 2, 3, 5, 6, 7           |
| j                  | VI b                                   | H            | VII b              | 1, 2                       |
| m                  | VI a                                   | B, D, F, H   |                    |                            |
| n                  | VI a                                   | A, C, E, G   |                    |                            |
| p                  |  |              | V                  | B- No CRN number available |
| t                  |  |              | III a              | J, K, 7, L, 8              |
| u                  |  |              | VIII a             | C, D                       |
| b                  | Select only one option from this group |              |                    |                            |

<sup>1</sup>The PM option is available on all Smartline Pressure Transmitter process wetted parts such as process heads, flanges, bushings and vent plugs except plated carbon steel process heads and flanges. PM option information is also available on diaphragms except Gold plated and STG and STA in-line construction pressure

**FIELD INSTALLABLE/ACCESSORY PARTS**

| Description   |
|---|
| Integrally Mounted Advanced Indicator Kit (EN, DE, FR, ES, IT, RU, TU - compatible with all Electronic Modules) |
| Integrally Mounted Advanced Indicator Kit (EN, CH, JP - compatible with all Electronic Modules)                 |
| Terminal Strip w/o Lightning Protection Kit for HART or DE Modules  |
| Terminal Strip w/o Lightning Protection FFB/ <i>Profibus</i> Module   |
| Terminal Strip w/ Lightning Protection Kit for FFB/ <i>Profibus</i> Module                                      |
| Terminal Strip w/ Lightning Protection Kit for HART or DE Modules   |
| HART Electronics Module   |
| HART Electronics Module w/ connection for external configuration buttons  |
| DE Electronics Module   |
| DE Electronics Module w/ connection for external configuration buttons  |

| Kit Number   |
|--------------|
| 50049846-506 |
| 50087087-503 |
| 50086421-521 |
| 50086421-507 |
| 50086421-509 |
| 50086421-523 |
| 50098718-501 |
| 50098718-502 |
| 50098718-503 |
| 50098718-504 |

## Sales and Service

For application assistance, current specifications, pricing, or name of the nearest Authorized Distributor, contact one of the offices below.

### ASIA PACIFIC

Honeywell Process Solutions,  
(TAC) [hfs-tac-support@honeywell.com](mailto:hfs-tac-support@honeywell.com)

#### Australia

Honeywell Limited  
Phone: +(61) 7-3846 1255  
FAX: +(61) 7-3840 6481  
Toll Free 1300-36-39-36  
Toll Free Fax:  
1300-36-04-70

#### China – PRC - Shanghai

Honeywell China Inc.  
Phone: (86-21) 5257-4568  
Fax: (86-21) 6237-2826

#### Singapore

Honeywell Pte Ltd.  
Phone: +(65) 6580 3278  
Fax: +(65) 6445-3033

#### South Korea

Honeywell Korea Co Ltd  
Phone: +(822) 799 6114  
Fax: +(822) 792 9015

### EMEA

Honeywell Process Solutions,  
Phone: + 80012026455 or  
+44 (0)1344 656000

Email: (Sales)

[FP-Sales-Apps@Honeywell.com](mailto:FP-Sales-Apps@Honeywell.com)

or

(TAC)

[hfs-tac-support@honeywell.com](mailto:hfs-tac-support@honeywell.com)

### AMERICA'S

Honeywell Process Solutions,  
Phone: (TAC) 1-800-423-9883 or  
215/641-3610  
(Sales) 1-800-343-0228

Email: (Sales)

[FP-Sales-Apps@Honeywell.com](mailto:FP-Sales-Apps@Honeywell.com)

or

(TAC)

[hfs-tac-support@honeywell.com](mailto:hfs-tac-support@honeywell.com)

*Specifications are subject to change without notice.*

### For more information

To learn more about SmartLine Transmitters,  
visit [www.honeywellprocess.com](http://www.honeywellprocess.com)  
Or contact your Honeywell Account Manager

### Process Solutions

Honeywell  
1250 W Sam Houston Pkwy S  
Houston, TX 77042

Honeywell Control Systems Ltd  
Honeywell House, Skimped Hill Lane  
Bracknell, England, RG12 1EB

Shanghai City Centre, 100 Jungi Road  
Shanghai, China 20061

[www.honeywellprocess.com](http://www.honeywellprocess.com)



**Honeywell**  
AUTHORIZED DISTRIBUTOR

**De Gidts & Feldman BV**  
**The Netherlands**  
**w w w . d g f g . n l**



**De Gidts & Feldman**  
INSTRUMENTATION & FILTRATION

**Honeywell**

34-SM-03-92

March 2017

©2017 Honeywell International Inc.