



TWC 9400 Handbook

Signal converter for mass flowmeters

Electronic Revision:
ER 2.0.2x

The documentation is only complete when used in combination with the relevant documentation for the flow sensor.

Honeywell

Notices and Trademarks

Copyright 2017 by Honeywell

WARRANTY/REMEDY

Honeywell warrants goods of its manufacture as being free of defective materials and faulty workmanship. Contact your local sales office for warranty information. If warranted goods are returned to Honeywell during the period of coverage, Honeywell will repair or replace without charge those items it finds defective. The foregoing is Buyer's sole remedy and is in lieu of all other warranties, expressed or implied, including those of merchantability and fitness for a particular purpose. Specifications may change without notice. The information we supply is believed to be accurate and reliable as of this printing. However, we assume no responsibility for its use.

While we provide application assistance personally, through our literature and the Honeywell web site, it is up to the customer to determine the suitability of the product in the application.

Honeywell Process Solutions
1250 W Sam Houston Pkwy S
Houston, TX 77042

Abstract

This document provides descriptions and procedures for the Installation, Configuration, Operation, and Troubleshooting of your device.

Contacts**World Wide Web:**

The following lists Honeywell's World Wide Web sites that will be of interest to our customers.

Honeywell Organization

Honeywell Corporate
Honeywell Process Solutions
Technical Assistance

WWW Address (URL)

www.honeywellprocess.com
www.honeywellprocess.com/flowmeters/
www.honeywellprocess.com

Telephone:

Contact us by telephone at the numbers listed below.

Organization

Global

Phone Number

Technical Support: 1-800-423-9883

Outside United States:

Technical Support: 001-215/641-3610

Customer Service

1-800-343-0228

1	Safety instructions	9
<hr/>		
1.1	Software history	9
1.2	Intended use	10
1.3	CE certification	10
1.4	Safety instructions from the manufacturer	11
1.4.1	Copyright and data protection	11
1.4.2	Disclaimer	11
1.4.3	Product liability and warranty	12
1.4.4	Information concerning the documentation	12
1.4.5	Warnings and symbols used	13
1.5	Safety instructions for the operator	13
2	Device description	15
<hr/>		
2.1	Scope of delivery	15
2.2	Device description	16
2.2.1	Field housing	17
2.3	Nameplates	18
2.3.1	Example of a nameplate	18
2.3.2	Electrical connection data of inputs/outputs (example of basic version)	19
3	Installation	21
<hr/>		
3.1	General notes on installation	21
3.2	Storage	21
3.3	Transport	21
3.4	Installation specifications	21
3.5	Mounting of the compact version	22
3.6	Mounting the field housing, remote version	22
3.6.1	Pipe mounting	22
3.6.2	Wall mounting	23
3.6.3	Turning the display of the field housing version	24
4	Electrical connections	25
<hr/>		
4.1	Safety instructions	25
4.2	Important notes on electrical connection	25
4.3	Signal cable requirements	26
4.4	Connecting the signal cables	27
4.4.1	Connection of signal cable - field housing and connection box for flow sensor	27
4.4.2	Connection diagram	29
4.5	Grounding the flow sensor	29
4.6	Connecting power - all housing variants	30
4.7	Inputs and outputs, overview	31
4.7.1	Combinations of the inputs/outputs (I/Os)	31
4.7.2	Description of the CG number	32
4.7.3	Fixed, non-alterable input/output versions	33
4.7.4	Alterable input/output versions	34

4.8	Description of the inputs and outputs	35
4.8.1	Current output	35
4.8.2	Pulse output and frequency output	36
4.8.3	Status output and limit switch	37
4.8.4	Control input	38
4.9	Electrical connection of the inputs and outputs	39
4.9.1	Field housing, electrical connection of the inputs and outputs	39
4.9.2	Laying electrical cables correctly.....	40
4.10	Description of the inputs and outputs	41
4.10.1	Important notes.....	41
4.10.2	Description of the electrical symbols.....	42
4.10.3	Modular inputs/outputs and bus systems	43
4.10.4	Ex i inputs/outputs	51
4.10.5	HART [®] connection	54
5	Start-up	57
<hr/>		
5.1	Switching on the power	57
5.2	Starting the signal converter	57
6	Operation	59
<hr/>		
6.1	Display and operating elements	59
6.1.1	Display in measuring mode with 2 or 3 measured values	61
6.1.2	Display for selection of submenu and functions, 3 lines	61
6.1.3	Display when setting parameters, 4 lines	62
6.1.4	Display when previewing parameters, 4 lines.....	62
6.1.5	Using an IR interface (option)	63
6.2	Menu structure	64
6.3	Function tables	68
6.3.1	Menu "Quick Setup"	68
6.3.2	Menu "Test".....	70
6.3.3	Menu "Setup"	72
6.3.4	Set free units.....	86
6.4	Calibration functions	87
6.4.1	Zero calibration (C1.1.1 Calibrate Zero)	87
6.4.2	Density calibration (C1.2.1 Calibrate Density).....	89
6.4.3	Temperature/density tables	91
6.5	Measurement functions	94
6.5.1	Flow (C1.1.0 Flow).....	94
6.5.2	Density (C1.2.0 Density)	96
6.5.3	System control (C1.4.0 System Control).....	97
6.5.4	Detection of 2 phase flow.....	98
6.6	I/O configuration	99
6.6.1	Damp output signals	99
6.6.2	Suppress small flow rates.....	99
6.6.3	Polarity of measurement	100
6.6.4	Current output	100
6.6.5	Alarm signalling via current outputs.....	101
6.6.6	Pulse output and batching applications	101

6.7	Display configuration.....	102
6.7.1	Optical keys (C5.3.0 Optical Keys).....	102
6.7.2	Backlight (C5.4.0 Backlight).....	102
6.8	Configuration management (C6.3.0 Config. Management).....	102
6.8.1	Load and save configuration (C6.3.2 & C6.3.1).....	102
6.8.2	Factory reset (C6.3.3 Factory Reset).....	102
6.8.3	Change log (B1.2.0 Change Log).....	103
6.8.4	Locking of configuration.....	103
6.9	Special functions.....	105
6.10	SIL configuration (only for SIL capable devices).....	105
6.11	Testing of device installation (B3.0.0 Simulation).....	105
6.12	Diagnostic information and status messages.....	106
6.12.1	Status groups (C6.6.0 Status Groups).....	107
6.12.2	Status log (B1.1.0 Status Log).....	108
6.12.3	Reset errors (A2.1.0 Reset Errors).....	108
7	Service	109
7.1	Replacing the signal converter electronics.....	109
7.2	Driver or sensor coil fault.....	110
7.2.1	VersaFlow Coriolis 100.....	110
7.2.2	VersaFlow Coriolis 200.....	111
7.2.3	VersaFlow Coriolis 6000.....	112
7.2.4	VersaFlow Coriolis 1000.....	113
7.3	Spare parts availability.....	114
7.4	Availability of services.....	114
7.5	Returning the device to the manufacturer.....	114
7.5.1	General information.....	114
7.5.2	Form (for copying) to accompany a returned device.....	115
7.6	Disposal.....	115
8	Technical data	117
8.1	Measuring principle.....	117
8.2	Technical data.....	117
8.3	Dimensions and weight.....	128
8.3.1	Housing.....	128
8.3.2	Mounting plate of field housing.....	128
9	Description of HART interface	129
9.1	General description.....	129
9.2	Software history.....	129
9.3	Connection variants.....	130
9.3.1	Point-to-Point connection - analogue / digital mode.....	131
9.3.2	Multi-Drop connection (2-wire connection).....	132
9.3.3	Multi-Drop connection (3-wire connection).....	133
9.4	Inputs/outputs and HART [®] dynamic variables and device variables.....	134

1.1 Software history

The "Electronic Revision" (ER) is consulted to document the revision status of electronic equipment according to NE 53 for all GDC devices. It is easy to see from the ER whether troubleshooting or larger changes in the electronic equipment have taken place and how that has affected the compatibility.

Changes and effect on compatibility

1	Downwards compatible changes and fault repair with no effect on operation (e.g. spelling mistakes on display)	
2- _	Downwards compatible hardware and/or software change of interfaces:	
	H	HART®
	P	PROFIBUS
	F	Foundation Fieldbus
	M	Modbus
	N	PROFINET IO
	X	all interfaces
3- _	Downwards compatible hardware and/or software change of inputs and outputs:	
	I	Current output
	F, P	Frequency / pulse output
	S	Status output
	C	Control input
	CI	Current input
	X	all inputs and outputs
4	Downwards compatible changes with new functions	
5	Incompatible changes, i.e. electronic equipment must be changed.	



INFORMATION!

In the table below, "x" is a placeholder for possible multi-digit alphanumeric combinations, depending on the available version.

Release date	Electronic Revision	Changes and compatibility	Documentation
2017	ER 2.0.0x	Initial version	iss.1 GLO July 17 US

Table 1-1: Software changes and effect on compatibility

1.2 Intended use

The mass flowmeters are designed exclusively to directly measure mass flow rates, product density and temperature as well to indirectly measure parameters such as the total volume and concentration of dissolved substances as well as the volume flow rate.

**DANGER!**

For devices used in hazardous areas, additional safety notes apply; please refer to the Ex documentation.

**CAUTION!**

For devices used in SIL applications, additional safety notes apply. For detailed information refer to the "Safety manual".

**WARNING!**

If the device is not used according to the operating conditions (refer to chapter "Technical data"), the intended protection could be affected.

**INFORMATION!**

This device is a Group 1, Class A device as specified within CISPR11:2009. It is intended for use in industrial environment. There may be potential difficulties in ensuring electromagnetic compatibility in other environments, due to conducted as well as radiated disturbances.

1.3 CE certification

CE marking



This device conforms with the most recent and up to date versions of the following:

- EMC Directive
- ATEX Directive
- Low Voltage Directive
- Pressure Equipment Directive

The manufacturer declares conformity and the device carries the CE mark.

1.4 Safety instructions from the manufacturer

1.4.1 Copyright and data protection

The contents of this document have been created with great care. Nevertheless, we provide no guarantee that the contents are correct, complete or up-to-date.

The contents and works in this document are subject to copyright. Contributions from third parties are identified as such. Reproduction, processing, dissemination and any type of use beyond what is permitted under copyright requires written authorisation from the respective author and/or the manufacturer.

The manufacturer tries always to observe the copyrights of others, and to draw on works created in-house or works in the public domain.

The collection of personal data (such as names, street addresses or e-mail addresses) in the manufacturer's documents is always on a voluntary basis whenever possible. Whenever feasible, it is always possible to make use of the offerings and services without providing any personal data.

We draw your attention to the fact that data transmission over the Internet (e.g. when communicating by e-mail) may involve gaps in security. It is not possible to protect such data completely against access by third parties.

We hereby expressly prohibit the use of the contact data published as part of our duty to publish an imprint for the purpose of sending us any advertising or informational materials that we have not expressly requested.

1.4.2 Disclaimer

The manufacturer will not be liable for any damage of any kind by using its product, including, but not limited to direct, indirect or incidental and consequential damages.

This disclaimer does not apply in case the manufacturer has acted on purpose or with gross negligence. In the event any applicable law does not allow such limitations on implied warranties or the exclusion of limitation of certain damages, you may, if such law applies to you, not be subject to some or all of the above disclaimer, exclusions or limitations.

Any product purchased from the manufacturer is warranted in accordance with the relevant product documentation and our Terms and Conditions of Sale.

The manufacturer reserves the right to alter the content of its documents, including this disclaimer in any way, at any time, for any reason, without prior notification, and will not be liable in any way for possible consequences of such changes.

1.4.3 Product liability and warranty

The operator shall bear responsibility for the suitability of the device for the specific purpose. The manufacturer accepts no liability for the consequences of misuse by the operator. Improper installation or operation of the devices (systems) will cause the warranty to be void. The respective "Standard Terms and Conditions" which form the basis for the sales contract shall also apply.

1.4.4 Information concerning the documentation

To prevent any injury to the user or damage to the device it is essential that you read the information in this document and observe applicable national standards, safety requirements and accident prevention regulations.

If this document is not in your native language and if you have any problems understanding the text, we advise you to contact your local office for assistance. The manufacturer can not accept responsibility for any damage or injury caused by misunderstanding of the information in this document.

This document is provided to help you establish operating conditions, which will permit safe and efficient use of this device. Special considerations and precautions are also described in the document, which appear in the form of icons as shown below.

1.4.5 Warnings and symbols used

Safety warnings are indicated by the following symbols.



DANGER!

This warning refers to the immediate danger when working with electricity.



DANGER!

This warning refers to the immediate danger of burns caused by heat or hot surfaces.



DANGER!

This warning refers to the immediate danger when using this device in a hazardous atmosphere.



DANGER!

These warnings must be observed without fail. Even partial disregard of this warning can lead to serious health problems and even death. There is also the risk of seriously damaging the device or parts of the operator's plant.



WARNING!

Disregarding this safety warning, even if only in part, poses the risk of serious health problems. There is also the risk of damaging the device or parts of the operator's plant.



CAUTION!

Disregarding these instructions can result in damage to the device or to parts of the operator's plant.



INFORMATION!

These instructions contain important information for the handling of the device.



LEGAL NOTICE!

This note contains information on statutory directives and standards.



• **HANDLING**

This symbol designates all instructions for actions to be carried out by the operator in the specified sequence.

➔ **RESULT**

This symbol refers to all important consequences of the previous actions.

1.5 Safety instructions for the operator



WARNING!

*In general, devices from the manufacturer may only be installed, commissioned, operated and maintained by properly trained and authorized personnel.
This document is provided to help you establish operating conditions, which will permit safe and efficient use of this device.*

2.1 Scope of delivery



INFORMATION!

Inspect the packaging carefully for damages or signs of rough handling. Report damage to the carrier and to the local office of the manufacturer.



INFORMATION!

Do a check of the packing list to make sure that you have all the elements given in the order.



INFORMATION!

Look at the device nameplate to ensure that the device is delivered according to your order. Check for the correct supply voltage printed on the nameplate.

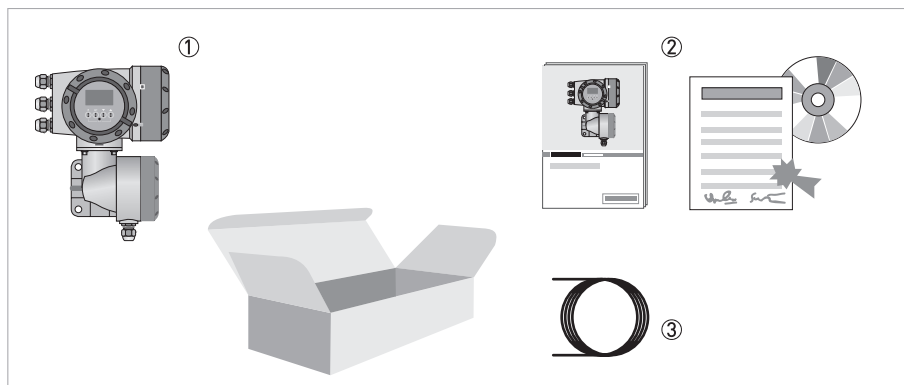


Figure 2-1: Scope of delivery

- ① Device in the version as ordered
- ② Documentation (calibration protocol, factory and material certification if ordered, CD-ROM with product documentation for flow sensor and signal converter)
- ③ Signal cable (only for remote version)

Flow sensor	Flow sensor + signal converter TWC 9400	
	Compact	Remote field housing
VersaFlow Coriolis 100	100 + TWC 9400 C	100 + TWC 9400 F
VersaFlow Coriolis 200	200 + TWC 9400 C	200 + TWC 9400 F
VersaFlow Coriolis 1000	1000 + TWC 9400 C	1000 + TWC 9400 F
VersaFlow Coriolis 6000	6000 + TWC 9400 C	6000 + TWC 9400 F

Table 2-1: Signal converter/flow sensor combination possibilities

2.2 Device description

The mass flowmeters are designed exclusively to directly measure mass flow rates, product density and temperature as well to indirectly measure parameters such as the total volume, concentration of dissolved substances and the volume flow rate.

Your measuring device is supplied ready for operation. The factory settings for the operating data have been made in accordance with your order specifications.

The following versions are available:

- Compact version (the signal converter is mounted directly on the flow sensor)
- Remote version (electrical connection to the flow sensor via field current and signal cable)

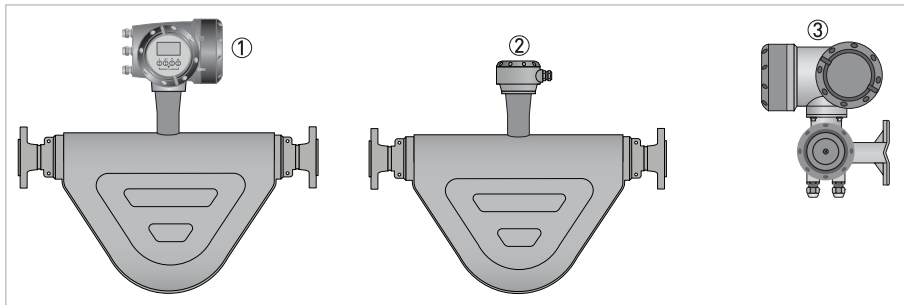


Figure 2-2: Versions with bent tube

- ① Compact version
- ② Flow sensor with connection box
- ③ Field housing

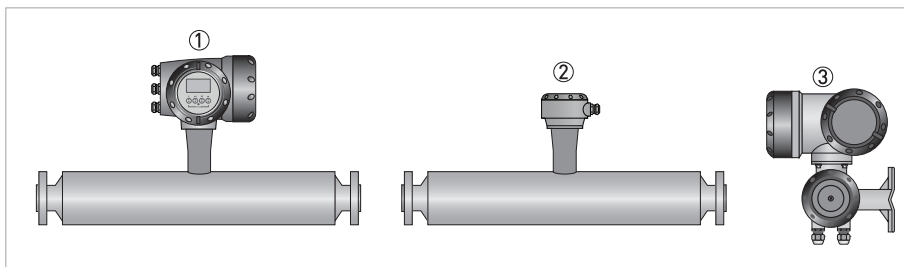


Figure 2-3: Versions with straight tube

- ① Compact version
- ② Flow sensor with connection box
- ③ Field housing

2.2.1 Field housing

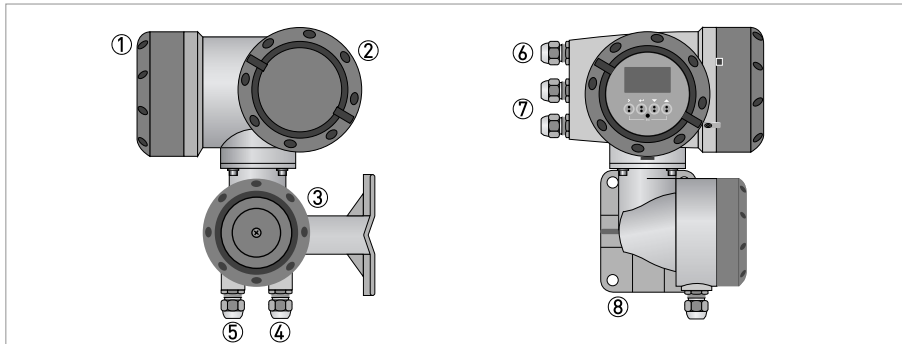


Figure 2-4: Construction of the field housing

- ① Cover for electronics and display
- ② Cover for power supply and inputs/outputs terminal compartment
- ③ Cover for flow sensor terminal compartment
- ④ Cable entry for flow sensor signal cable
- ⑤ Cable entry for flow sensor field current cable
- ⑥ Cable entry for power supply
- ⑦ Cable entry for inputs and outputs
- ⑧ Mounting plate for pipe and wall mounting



INFORMATION!

Each time a housing cover is opened, the thread should be cleaned and greased. Use only resin-free and acid-free grease.

Ensure that the housing gasket is properly fitted, clean and undamaged.

2.3 Nameplates



INFORMATION!

Look at the device nameplate to ensure that the device is delivered according to your order. Check for the correct supply voltage printed on the nameplate.

2.3.1 Example of a nameplate

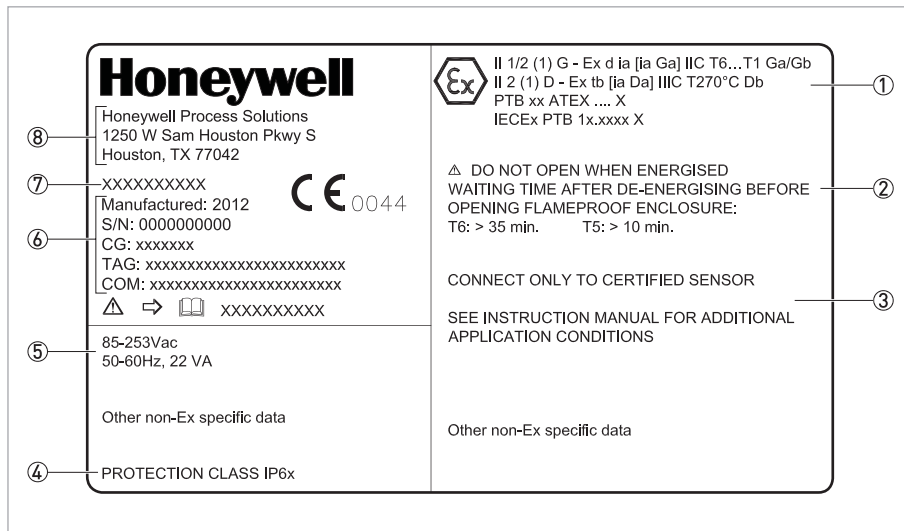


Figure 2-5: Example of a nameplate

- ① Approvals-related information: Ex approval, EC type test certificate, hygienic approvals, etc.
- ② Approvals-related thresholds
- ③ Additional information on documentation, calibration and patents
- ④ Protection category
- ⑤ Electrical connection data
- ⑥ Software and hardware revision (Electronics Revision), CG number, order number for signal converter and flow sensor
- ⑦ Product designation
- ⑧ Manufacturer address

2.3.2 Electrical connection data of inputs/outputs (example of basic version)

①	POWER	PE (FE) L(L+) N(L-)	S/N: G150000007402889 CG: CG430114AC A = Active P = Passive NC = Not connected	Honeywell
②	INPUT / OUTPUT	D - D	A	PULSE OUT / STATUS OUT I _{max} = 100 mA@f<= 10 Hz; = 20 mA@f<=12 kHz V _o = 1.5 V @ 10 mA; V _{nom} = 24 VDC
③		C - C	A	CURRENT OUT (HART) I <= 22 mA; R _{Lmax} = 1 kohm
④		B - B	A	PULSE OUT/STATUS OUT I _{max} = 100 mA@f<=10 Hz; = 20 mA@f<=12 kHz V _o = 1.5 V @ 10 mA; V _{nom} = 24 VDC
⑤		A + A -	NC	CURRENT OUT
		A	A	I <= 22 mA; R _{Lmax} = 1kohm

Figure 2-6: Example of a nameplate for electrical connection data of inputs and outputs

- ① Power supply (AC: L and N; DC: L+ and L-; PE for ≥ 24 VAC; FE for ≤ 24 VAC and DC)
 ② Connection data of connection terminal D/D-
 ③ Connection data of connection terminal C/C-
 ④ Connection data of connection terminal B/B-
 ⑤ Connection data of connection terminal A/A-; A+ only operable in the basic version

- A = active mode; the signal converter supplies the power for connection of the subsequent devices
- P = passive mode; external power supply required for operation of the subsequent devices
- N/C = connection terminals not connected

3.1 General notes on installation

**INFORMATION!**

Inspect the packaging carefully for damages or signs of rough handling. Report damage to the carrier and to the local office of the manufacturer.

**INFORMATION!**

Do a check of the packing list to make sure that you have all the elements given in the order.

**INFORMATION!**

Look at the device nameplate to ensure that the device is delivered according to your order. Check for the correct supply voltage printed on the nameplate.

3.2 Storage

- Store the device in a dry, dust-free location.
- Avoid continuous direct sunlight.
- Store the device in its original packing.
- Storage temperature: -40...+70°C / -40...+158°F

3.3 Transport

Signal converter

- No special requirements.

Compact version

- Do not lift the device by the signal converter housing.
- Do not use lifting chains.
- To transport flange devices, use lifting straps. Wrap these around both process connections.

3.4 Installation specifications

**INFORMATION!**

The following precautions must be taken to ensure reliable installation.

- *Make sure that there is adequate space to the sides.*
- *The device must not be heated by radiated heat (e.g. exposure to the sun) to a electronics housing surface temperature above the maximum permissible ambient temperature. If it is necessary to prevent damage from heat sources, a heat protection (e.g. sun shade) has to be installed.*
- *Signal converters installed in control cabinets require adequate cooling, e.g. by fan or heat exchanger.*
- *Do not expose the signal converter to intense vibrations. The measuring devices are tested for a vibration level as described in the chapter "Technical data".*

3.5 Mounting of the compact version



CAUTION!

Turning the housing of the compact version is not permitted.



INFORMATION!

The signal converter is mounted directly on the flow sensor. For installation of the flowmeter, please observe the instructions in the supplied product documentation for the flow sensor.

3.6 Mounting the field housing, remote version



CAUTION!

Remarks for sanitary applications

- *To prevent contamination and dirt deposits behind the mounting plate, a cover plug must be installed between the wall and the mounting plate.*
- *Pipe mounting is not suitable for sanitary applications!*



INFORMATION!

Assembly materials and tools are not part of the delivery. Use the assembly materials and tools in compliance with the applicable occupational health and safety directives.

3.6.1 Pipe mounting

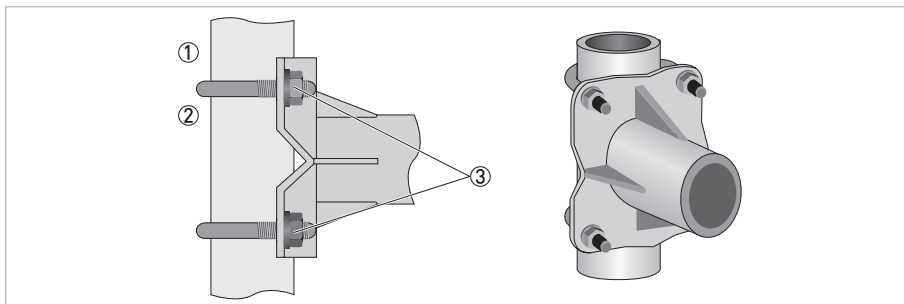


Figure 3-1: Pipe mounting of the field housing



- ① Fix the signal converter to the pipe.
- ② Fasten the signal converter using standard U-bolts and washers.
- ③ Tighten the nuts.

3.6.2 Wall mounting

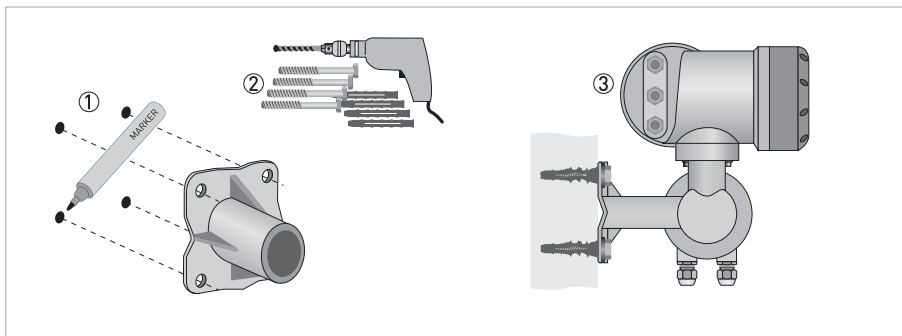


Figure 3-2: Wall mounting of the field housing



- ① Prepare the holes with the aid of the mounting plate. For further information refer to *Mounting plate of field housing* on page 128.
- ② Fasten the mounting plate securely to the wall.
- ③ Screw the signal converter to the mounting plate with the nuts and washers.

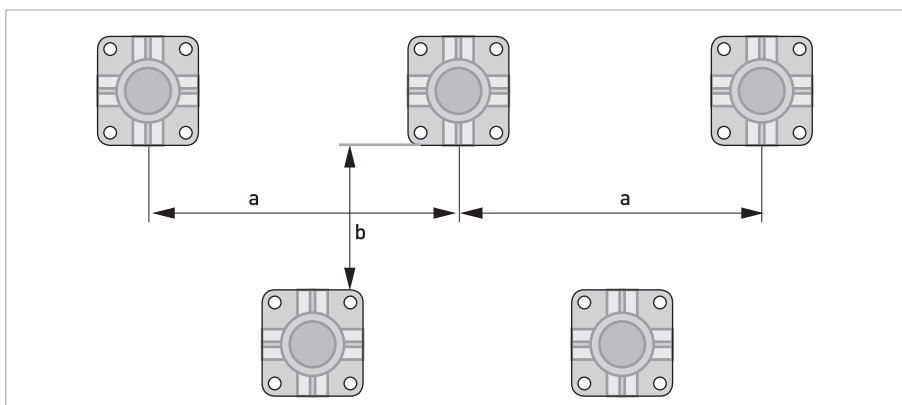


Figure 3-3: Mounting multiple devices next to each other

$a \geq 600 \text{ mm} / 23.6''$
 $b \geq 250 \text{ mm} / 9.8''$

3.6.3 Turning the display of the field housing version

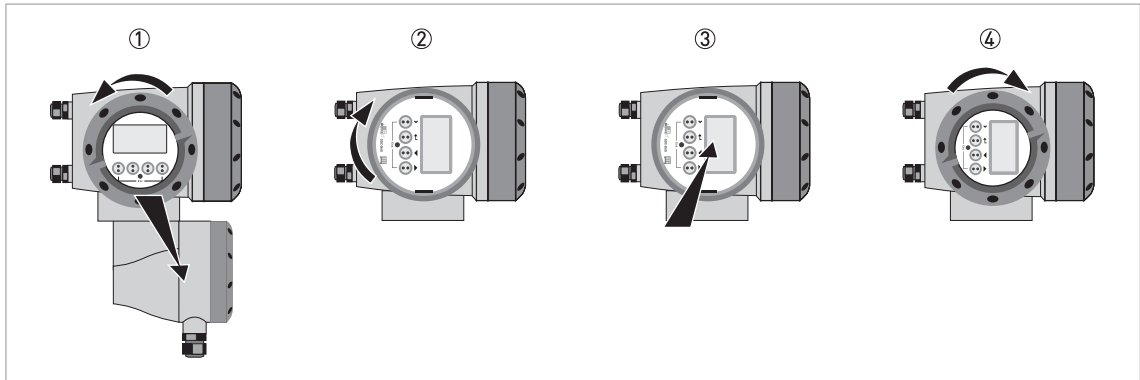


Figure 3-4: Turning the display of the field housing version



The display of the field housing version can be turned in 90° increments

- ① Unscrew the cover from the display and operation control unit.
- ② Pull out the display and rotate it to the required position.
- ③ Slide the display back into the housing.
- ④ Re-fit the cover and tighten it by hand.



CAUTION!

The ribbon cable of the display must not be folded or twisted repeatedly.



INFORMATION!

*Each time a housing cover is opened, the thread should be cleaned and greased. Use only resin-free and acid-free grease.
Ensure that the housing gasket is properly fitted, clean and undamaged.*

4.1 Safety instructions

**DANGER!**

All work on the electrical connections may only be carried out with the power disconnected. Take note of the voltage data on the nameplate!

**DANGER!**

Observe the national regulations for electrical installations!

**DANGER!**

For devices used in hazardous areas, additional safety notes apply; please refer to the Ex documentation.

**WARNING!**

Observe without fail the local occupational health and safety regulations. Any work done on the electrical components of the measuring device may only be carried out by properly trained specialists.

**INFORMATION!**

Look at the device nameplate to ensure that the device is delivered according to your order. Check for the correct supply voltage printed on the nameplate.

4.2 Important notes on electrical connection

**DANGER!**

Electrical connection is carried out in conformity with the VDE 0100 directive "Regulations for electrical power installations with line voltages up to 1000 V" or equivalent national regulations.

**CAUTION!**

- *Use suitable cable entries for the various electrical cables.*
- *The flow sensor and signal converter have been configured together at the factory. For this reason, please connect the devices in pairs.*

4.3 Signal cable requirements

**CAUTION!**

It is strongly recommended that the signal cable for remote meters is provided by the manufacturer.

Specifications for standard signal cables

- 5 twisted pair circuits (24 AWG)
- Insulation thickness of cables: ≥ 0.2 mm / 0.008"
- Each cable pair shielded with foil and drain wire
- Overall foil/braid shield
- Casing colour: grey
- Colour of wires:
 - Pair 1: yellow/black
 - Pair 2: green/black
 - Pair 3: blue/black
 - Pair 4: red/black
 - Pair 5: white/black
- Test voltage: ≥ 100 VAC
- Temperature range: $-40\dots+85^{\circ}\text{C}$ / $-40\dots+185^{\circ}\text{F}$
- Capacity between cables: ≤ 41 pF/m
- Capacity compared to shielding: ≤ 73 pF/m
- Inductance: ≤ 0.8 $\mu\text{H/m}$

Specifications for cables in hazardous areas

- 5 twisted pair circuits (24 AWG)
- Insulation thickness of cables: ≥ 0.2 mm / 0.008"
- Each cable pair shielded with foil and drain wire
- Overall foil/braid shield
- Casing colour: blue
- Colour of wires:
 - Pair 1: yellow/black
 - Pair 2: green/black
 - Pair 3: blue/black
 - Pair 4: red/black
 - Pair 5: white/black
- Test voltage: ≥ 100 VAC
- Temperature range: $-40\dots+85^{\circ}\text{C}$ / $-40\dots+185^{\circ}\text{F}$
- Capacity between cables: ≤ 41 pF/m
- Capacity compared to shielding: ≤ 73 pF/m
- Inductance: ≤ 0.8 $\mu\text{H/m}$

4.4 Connecting the signal cables



DANGER!

Cables may only be connected when the power is switched off.



DANGER!

The device must be grounded in accordance with regulations in order to protect personnel against electric shocks.



DANGER!

For devices used in hazardous areas, additional safety notes apply; please refer to the Ex documentation.



WARNING!

Observe without fail the local occupational health and safety regulations. Any work done on the electrical components of the measuring device may only be carried out by properly trained specialists.

4.4.1 Connection of signal cable - field housing and connection box for flow sensor

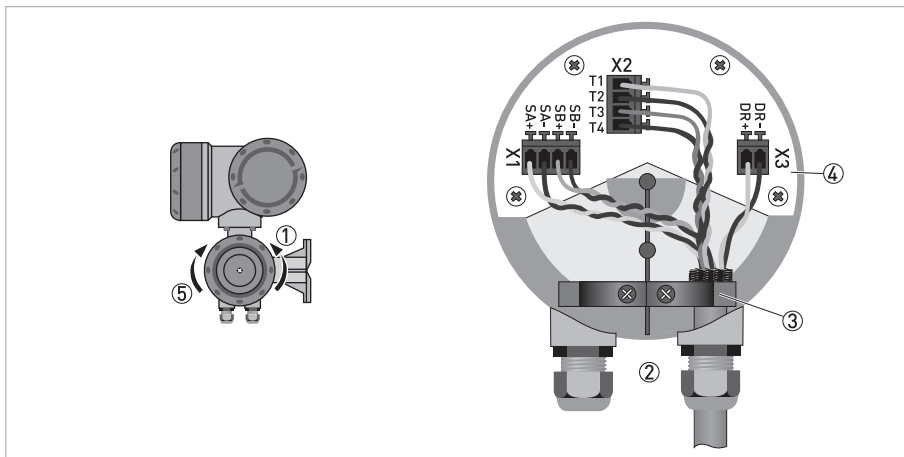


Figure 4-1: Connection of signal cable - field housing and connection box for flow sensor



- ① Unscrew the terminal compartment cover.
- ② Pass the prepared signal cable through the cable entry.
- ③ Secure the signal cable using the clip.
- ④ Connect the electrical conductors as shown. The shielding must also be connected to the spring terminal.
- ⑤ Re-fit the cover and tighten it by hand.

Cable		Connection terminal
Cable pair	Colour	
1	yellow	X1 SA+
1	black	X1 SA-
2	green	X1 SB+
2	black	X1 SB-
3	blue	X2 T1
3	black	X2 T2
4	red	X2 T3
4	black	X2 T4
5	white	X3 DR+
5	black	X3 DR-

Table 4-1: Colour coding of cables

**INFORMATION!**

Each time a housing cover is opened, the thread should be cleaned and greased. Use only resin-free and acid-free grease.

Ensure that the housing gasket is properly fitted, clean and undamaged.

4.4.2 Connection diagram



DANGER!

The device must be grounded in accordance with regulations in order to protect personnel against electric shocks.

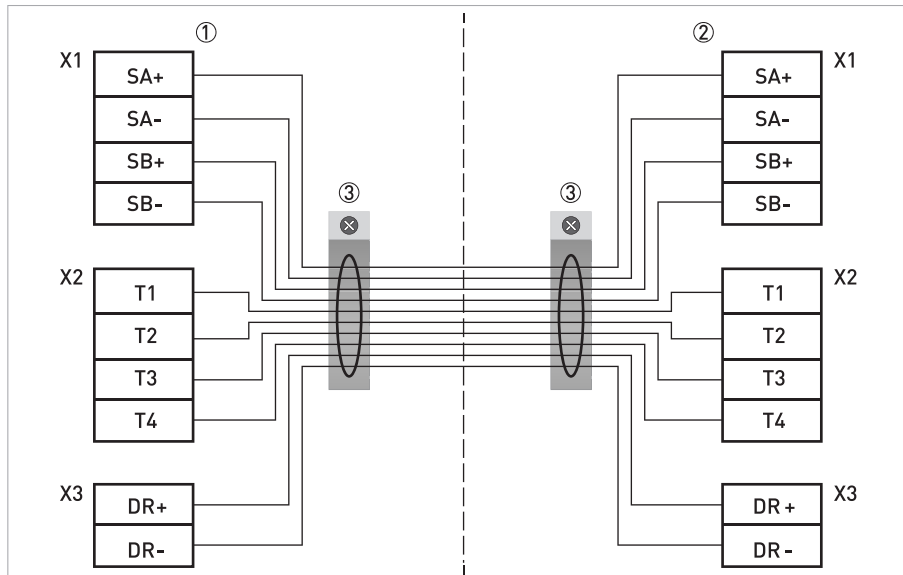


Figure 4-2: Connection diagram

- ① Terminal compartment for signal converter
- ② Terminal compartment for flow sensor
- ③ Connect shielding to spring terminal (drain wire and overall shield)

4.5 Grounding the flow sensor



DANGER!

There should be no difference in potential between the flow sensor and the housing or protective earth of the signal converter!

- The flow sensor must be properly grounded.
- The grounding cable should not transmit any interference voltages.
- Do not use the grounding cable to connect more than one device to ground.
- The flow sensors are connected to ground by means of a functional grounding conductor FE.
- In hazardous areas, grounding is used at the same time for equipotential bonding. Additional grounding instructions are provided in the supplementary "Ex documentation", which are only supplied together with hazardous area equipment.

4.6 Connecting power - all housing variants

**DANGER!**

The device must be grounded in accordance with regulations in order to protect personnel against electric shocks.

**DANGER!**

For devices used in hazardous areas, additional safety notes apply; please refer to the Ex documentation.

- The protection category depends on the housing versions (IP65...67 or NEMA4/4X/6).
- The housings of the devices, which are designed to protect the electronic equipment from dust and moisture, should be kept well closed at all times. Creepage distances and clearances are dimensioned to VDE 0110 and IEC 60664 for pollution severity 2. Supply circuits are designed for overvoltage category III and the output circuits for overvoltage category II.
- Fuse protection ($I_N \leq 16$ A) for the infeed power circuit, as well as a separator (switch, circuit breaker) to isolate the signal converter must be provided close to the device. The separator must be marked as the separator for this device.

100...230 VAC (tolerance range: -15% / +10%)

- Note the power supply voltage and frequency (50...60 Hz) on the nameplate.
- The protective ground terminal **PE** of the power supply must be connected to the separate U-clamp terminal in the terminal compartment of the signal converter

**INFORMATION!**

240 VAC + 5% is included in the tolerance range.

24 VDC (tolerance range: -55% / +30%)

- Note the data on the nameplate!
- For measurement process reasons, a functional ground **FE** must be connected to the separate U-clamp terminal in the terminal compartment of the signal converter.
- When connecting to functional extra-low voltages, provide a facility for protective separation (PELV) (acc. to VDE 0100 / VDE 0106 and/or IEC 60364 / IEC 61140 or relevant national regulations).

**INFORMATION!**

For 24 VDC, 12 VDC - 10% is included in the tolerance range.

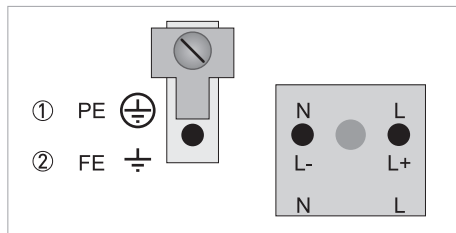


Figure 4-3: Power supply connection

- ① 100...230 VAC (-15% / +10%), 22 VA
- ② 24 VDC (-55% / +30%), 12 W

4.7 Inputs and outputs, overview

4.7.1 Combinations of the inputs/outputs (I/Os)

This signal converter is available with various input/output combinations.

Modular version

- Depending on the task, the device can be configured with various output modules.

Ex i version

- Depending on the task, the device can be configured with various output modules.
- Current outputs can be active or passive.
- Optionally available also with Foundation Fieldbus and Profibus PA

Bus systems

- The device allows intrinsically safe and non intrinsically safe bus interfaces in combination with additional modules.
- For connection and operation of bus systems, note the supplementary instructions.

Ex option

- For hazardous areas, all of the input/output variants for the housing designs C and F can be delivered with terminal compartment in Ex d (pressure-resistant casing) or Ex e (increased safety).
- For connection and operation of Ex devices, note the supplementary instructions.

4.7.2 Description of the CG number

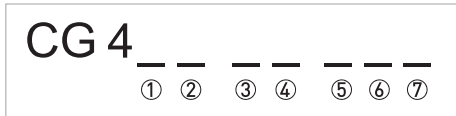


Figure 4-4: Marking (CG number) of the electronics module and input/output variants

- ① ID number: 3
- ② ID number: 0 = standard
- ③ Power supply option
- ④ Display
- ⑤ Input/output version (I/O)
- ⑥ 1st optional module for connection terminal A
- ⑦ 2nd optional module for connection terminal B

The last 3 digits of the CG number (⑤, ⑥ and ⑦) indicate the assignment of the terminal connections. Please refer to the following examples.

CG430114AC	100...230 VAC & standard display; modular I/O: I _a & P _N /S _N and optional module I _a /S _N & P _a /S _a
CG43081200	24 VDC & standard display; Ex i I/O: I _a & P _a /S _a and optional module I _a & P _N /S _N /C _N

Table 4-2: Examples for CG number

Abbreviation	Identifier for CG number	Description
I _a	A	Active current output
I _p	B	Passive current output
P _a / S _a	C	Active pulse output, frequency output, status output or limit switch (changeable)
P _p / S _p	E	Passive pulse output, frequency output, status output or limit switch (changeable)
P _N / S _N	F	Passive pulse output, frequency output, status output or limit switch acc. to NAMUR (changeable)
C _a	G	Active control input
C _p	K	Passive control input
C _N	H	Active control input acc. to NAMUR Signal converter monitors cable breaks and short circuits acc. to EN 60947-5-6. Errors indicated on LC display. Error messages possible via status output.
-	8	No additional module installed
-	0	No further module possible

Table 4-3: Description of abbreviations and CG identifier for possible optional modules on terminals A and B

4.7.3 Fixed, non-alterable input/output versions

This signal converter is available with various input/output combinations.

- The grey boxes in the tables denote unassigned or unused connection terminals.
- In the table, only the final digits of the CG no. are depicted.

CG no.	Connection terminals								
	A+	A	A-	B	B-	C	C-	D	D-

Ex i I/Os (option)

2 0 0						$I_a + \text{HART}^{\text{®}}$ active		P_N / S_N NAMUR ①
3 0 0						$I_p + \text{HART}^{\text{®}}$ passive		P_N / S_N NAMUR ①
2 1 0		I_a active		P_N / S_N NAMUR C_p passive ①		$I_a + \text{HART}^{\text{®}}$ active		P_N / S_N NAMUR ①
3 1 0		I_a active		P_N / S_N NAMUR C_p passive ①		$I_p + \text{HART}^{\text{®}}$ passive		P_N / S_N NAMUR ①
2 2 0		I_p passive		P_N / S_N NAMUR C_p passive ①		$I_a + \text{HART}^{\text{®}}$ active		P_N / S_N NAMUR ①
3 2 0		I_p passive		P_N / S_N NAMUR C_p passive ①		$I_p + \text{HART}^{\text{®}}$ passive		P_N / S_N NAMUR ①

PROFIBUS PA (Ex i) (option)

D 0 0						PA+	PA-	PA+	PA-
						FISCO Device		FISCO Device	
D 1 0		I_a active		P_N / S_N NAMUR C_p passive ①		PA+	PA-	PA+	PA-
						FISCO Device		FISCO Device	
D 2 0		I_p passive		P_N / S_N NAMUR C_p passive ①		PA+	PA-	PA+	PA-
						FISCO Device		FISCO Device	

FOUNDATION Fieldbus (Ex i) (option)

E 0 0						V/D+	V/D-	V/D+	V/D-
						FISCO Device		FISCO Device	
E 1 0		I_a active		P_N / S_N NAMUR C_p passive ①		V/D+	V/D-	V/D+	V/D-
						FISCO Device		FISCO Device	
E 2 0		I_p passive		P_N / S_N NAMUR C_p passive ①		V/D+	V/D-	V/D+	V/D-
						FISCO Device		FISCO Device	

PROFINET IO (option)

N 0 0		RX+	RX-	TX+	TX-	TX+	TX-	RX+	RX-
		Port 2				Port 1			

Table 4-4: Electrical connection of fixed, non-alterable input/output versions

① Changeable

4.7.4 Alterable input/output versions

This signal converter is available with various input/output combinations.

- The grey boxes in the tables denote unassigned or unused connection terminals.
- In the table, only the final digits of the CG no. are depicted.
- Term. = (connection) terminal

CG no.	Connection terminals									
	A+	A	A-	B	B-	C	C-	D	D-	

Modular I/Os (option)

4 __		max. 2 optional modules for term. A + B		I + HART® active/passive ①		P/S active/passive/ NAMUR ①
------	--	-----------------------------------------	--	-------------------------------	--	--------------------------------

PROFIBUS PA (option)

D __		max. 2 optional modules for term. A + B		PA+ (2)	PA- (2)	PA+ (1)	PA- (1)
------	--	-----------------------------------------	--	---------	---------	---------	---------

FOUNDATION Fieldbus (option)

E __		max. 2 optional modules for term. A + B		V/D+ (2)	V/D- (2)	V/D+ (1)	V/D- (1)
------	--	-----------------------------------------	--	----------	----------	----------	----------

PROFIBUS DP (option)

F _0		1 optional module for term. A	Termination P	RxD/TxD-P(2)	RxD/TxD-N(2)	Termination N	RxD/TxD-P(1)	RxD/TxD-N(1)
------	--	-------------------------------	---------------	--------------	--------------	---------------	--------------	--------------

Modbus (option)

G __ ②		max. 2 optional modules for term. A + B		Common	Sign. B (D1)	Sign. A (D0)
H __ ③		max. 2 optional modules for term. A + B		Common	Sign. B (D1)	Sign. A (D0)

Table 4-5: Electrical connection of alterable input/output versions

- ① Software configurable
- ② Not activated bus terminator
- ③ Activated bus terminator

4.8 Description of the inputs and outputs

4.8.1 Current output

**INFORMATION!**

- *The current outputs must be connected depending on the version! Which I/O versions and inputs/outputs are installed in your signal converter are indicated on the sticker in the cover of the terminal compartment.*
- *For Modular I/Os, the current output at terminal C must be configured to active/passive before connecting it.*
- All outputs are electrically isolated from each other and from all other circuits.
- All operating data and functions can be adjusted.
- Passive mode:
External power supply required: $U_{\text{ext}} \leq 30 \text{ VDC}$ at $I \leq 22 \text{ mA}$
- Active mode:
Load impedance $R_L \leq 1 \text{ k}\Omega$ at $I \leq 22 \text{ mA}$;
 $R_L \leq 400 \Omega$ at $I \leq 22 \text{ mA}$ for Ex i outputs
- Self-monitoring: interruption or load impedance too high in the current output loop
- Error message possible via status output, error indication on LC display.
- Alarm signal can be adjusted. Default setting: 3.5 mA
- Automatic range conversion via threshold or control input is available for current output at terminal A or B. The range for the threshold is between 5 and 80% of $Q_{100\%}$, $\pm 0...5\%$ hysteresis (corresponding ratio from smaller to larger range of 1:20 to 1:1.25). Signalling of the active range possible via a status output (adjustable).
- Forward/reverse flow measurement (F/R mode) is possible.

**INFORMATION!**

For further information refer to Description of the inputs and outputs on page 41 and refer to Technical data on page 117.

**DANGER!**

For devices used in hazardous areas, additional safety notes apply; please refer to the Ex documentation.

4.8.2 Pulse output and frequency output

**INFORMATION!**

- Depending on the version, the pulse and frequency outputs must be connected passively or actively or according to NAMUR EN 60947-5-6! Which I/O version and inputs/outputs are installed in your signal converter are indicated on the sticker in the cover of the terminal compartment.
- For Modular I/Os, the pulse output or frequency output at terminal D must be configured to active/passive/NAMUR before connecting it.
- All outputs are electrically isolated from each other and from all other circuits.
- All operating data and functions can be adjusted.
- Passive mode:
External power supply required: $U_{ext} \leq 32$ VDC;
 $I \leq 20$ mA at $f \leq 10$ kHz (over range up to $f_{max} \leq 12$ kHz);
 $I \leq 100$ mA at $f \leq 100$ Hz
- Active mode:
Use of the internal power supply: $U_{nom} = 24$ VDC;
 $I \leq 20$ mA at $f \leq 10$ kHz (over range up to $f_{max} \leq 12$ kHz);
 $I \leq 20$ mA at $f \leq 100$ Hz
- NAMUR mode:
Passive in accordance with EN 60947-5-6;
 $f \leq 10$ kHz (over range up to $f_{max} \leq 12$ kHz)
- Scaling:
Frequency output: in pulses per time unit (e.g. 1000 pulses/s at $Q_{100\%}$);
Pulse output: quantity per pulse
- Pulse width:
symmetric (pulse duty factor 1:1, independent of output frequency),
automatic (with fixed pulse width, duty factor approx. 1:1 at $Q_{100\%}$) or
fixed (pulse width adjustable as required from 0.05 ms...2 s)
- When pulse shape is set to fixed, then the maximum pulse rate/frequency is limited to $1/(1.5 * \text{pulse width})$.
- If output pulse rate is limited, pulses are cached and will continue to be transmitted even when the flow rate falls to zero.
- Forward/reverse flow measurement (F/R mode) is possible.
- All pulse and frequency outputs can also be used as a status output / limit switch.

**INFORMATION!**

For further information refer to Description of the inputs and outputs on page 41 and refer to Technical data on page 117.

**DANGER!**

For devices used in hazardous areas, additional safety notes apply; please refer to the Ex documentation.

4.8.3 Status output and limit switch

**INFORMATION!**

- Depending on the version, the status outputs and limit switches must be connected passively or actively or according to NAMUR EN 60947-5-6! Which I/O version and inputs/outputs are installed in your signal converter are indicated on the sticker in the cover of the terminal compartment.
- For Modular I/Os, the status output at terminal D must be configured to active/passive/NAMUR before connecting it.
- The status outputs / limit switches are electrically isolated from each other and from all other circuits.
- The output stages of the status outputs / limit switches during simple active or passive operation behave like relay contacts and can be connected with any polarity.
- All operating data and functions can be adjusted.
- Passive mode:
External power supply required: $U_{\text{ext}} \leq 32 \text{ VDC}$ at $I \leq 100 \text{ mA}$
- Active mode:
Use of the internal power supply: $U_{\text{nom}} = 24 \text{ VDC}$ at $I \leq 20 \text{ mA}$
- NAMUR mode:
Passive in accordance with EN 60947-5-6

**INFORMATION!**

For further information refer to *Description of the inputs and outputs* on page 41 and refer to *Technical data* on page 117.

**DANGER!**

For devices used in hazardous areas, additional safety notes apply; please refer to the *Ex documentation*.

4.8.4 Control input

**INFORMATION!**

Depending on the version, the control inputs must be connected passively or actively or according to NAMUR EN 60947-5-6! Which I/O version and inputs/outputs are installed in your signal converter are indicated on the sticker in the cover of the terminal compartment.

- All control inputs are electrically isolated from each other and from all other circuits.
- All operating data and functions can be adjusted.
- Passive mode:
External power supply required: $U_{\text{ext}} \leq 32 \text{ VDC}$
- Active mode:
Use of the internal power supply: $U_{\text{nom}} = 24 \text{ VDC}$
- NAMUR mode:
In accordance with EN 60947-5-6
{Active control input to NAMUR EN 60947-5-6: signal converter monitors cable breaks and short circuits acc. to EN 60947-5-6. Errors indicated on LC display. Error messages possible via status output.

**INFORMATION!**

For further information refer to Description of the inputs and outputs on page 41 and refer to Technical data on page 117.

**DANGER!**

For devices used in hazardous areas, additional safety notes apply; please refer to the Ex documentation.

4.9 Electrical connection of the inputs and outputs



CAUTION!

I/O connections must not be connected to DC power supply networks.



INFORMATION!

Assembly materials and tools are not part of the delivery. Use the assembly materials and tools in compliance with the applicable occupational health and safety directives.

4.9.1 Field housing, electrical connection of the inputs and outputs



DANGER!

All work on the electrical connections may only be carried out with the power disconnected. Take note of the voltage data on the nameplate!



INFORMATION!

For frequencies above 100 Hz, shielded cables are to be used in order to reduce effects from electrical interferences (EMC).

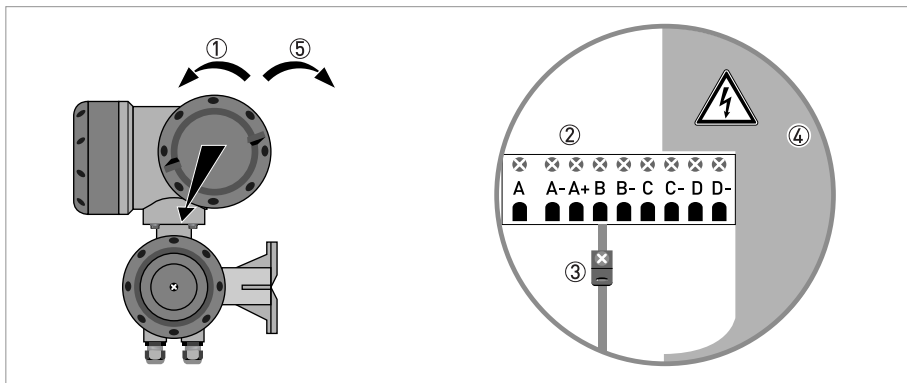


Figure 4-5: Terminal compartment for inputs and outputs in field housing



- ① Open the housing cover.
- ② Push the prepared cable through the cable entry and connect the necessary conductors.
- ③ Connect the shield if necessary.
- ④ Close the touch guard.
- ⑤ Close the housing cover.



INFORMATION!

Each time a housing cover is opened, the thread should be cleaned and greased. Use only resin-free and acid-free grease.

Ensure that the housing gasket is properly fitted, clean and undamaged.

4.9.2 Laying electrical cables correctly

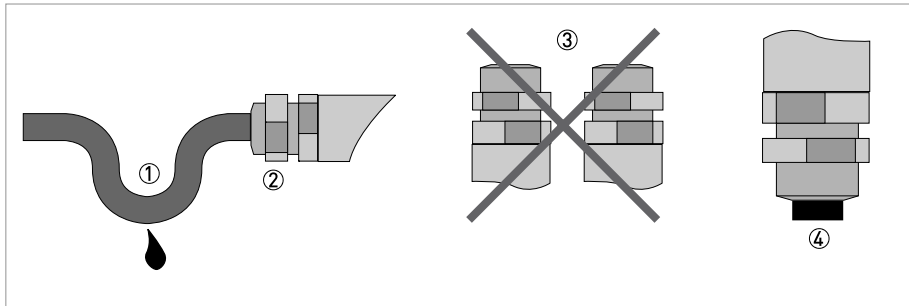


Figure 4-6: Protect housing from dust and water



- ① Lay the cable in a loop just before the housing.
- ② Tighten the screw connection of the cable entry securely.
- ③ Never mount the housing with the cable entries facing upwards.
- ④ Seal cable entries that are not needed with a plug.

4.10 Description of the inputs and outputs

4.10.1 Important notes



INFORMATION!

Depending on the version, the inputs/outputs must be connected passively or actively or acc. to NAMUR EN 60947-5-6! Which I/O version and inputs/outputs are installed in your signal converter are indicated on the sticker in the cover of the terminal compartment.

- All groups are electrically isolated from each other and from all other input and output circuits.
- Passive mode: An external power supply is necessary to operate (activation) the subsequent devices (U_{ext}).
- Active mode: The signal converter supplies the power for operation (activation) of the subsequent devices, observe max. operating data.
- Terminals that are not used should not have any conductive connection to other electrically conductive parts.



DANGER!

For devices used in hazardous areas, additional safety notes apply; please refer to the Ex documentation.

I_a	I_p	Current output active or passive
P_a	P_p	Pulse/frequency output active or passive
P_N		Pulse/frequency output passive acc. to NAMUR EN 60947-5-6
S_a	S_p	Status output/limit switch active or passive
S_N		Status output/limit switch passive acc. to NAMUR EN 60947-5-6
C_a	C_p	Control input active or passive
C_N		Control input active acc. to NAMUR EN 60947-5-6: Signal converter monitors cable breaks and short circuits acc. to EN 60947-5-6. Errors indicated on LC display. Error messages possible via status output.

Table 4-6: Description of used abbreviations

4.10.2 Description of the electrical symbols


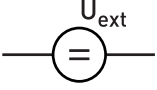
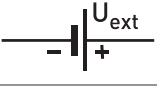
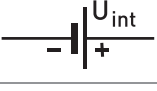
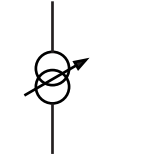
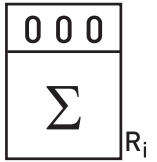
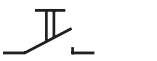
	<p>mA meter 0...20 mA or 4...20 mA and other R_L is the internal resistance of the measuring point including the cable resistance</p>
	<p>DC voltage source (U_{ext}), external power supply, any connection polarity</p>
	<p>DC voltage source (U_{ext}), observe connection polarity according to connection diagrams</p>
	<p>Internal DC voltage source</p>
	<p>Controlled internal power source in the device</p>
	<p>Electronic or electromagnetic counter At frequencies above 100 Hz, shielded cables must be used to connect the counters. R_i Internal resistance of the counter</p>
	<p>Button, N/O contact or similar</p>

Table 4-7: Description of the electrical symbols

4.10.3 Modular inputs/outputs and bus systems



CAUTION!

- Observe connection polarity.
- Configure the outputs at terminal C and D before connecting them.



INFORMATION!

- For further information refer to Description of the inputs and outputs on page 35.
- The electrical connection of the bus systems are described in the supplementary instructions of the respective bus system.

Current output active (only current output terminals C/C- have HART[®] capability), modular I/Os

- $U_{\text{int, nom}} = 24 \text{ VDC}$
- $I \leq 22 \text{ mA}$
- $R_L \leq 1 \text{ k}\Omega$
- X designates the connection terminals A, B or C, depending on the version of the signal converter.

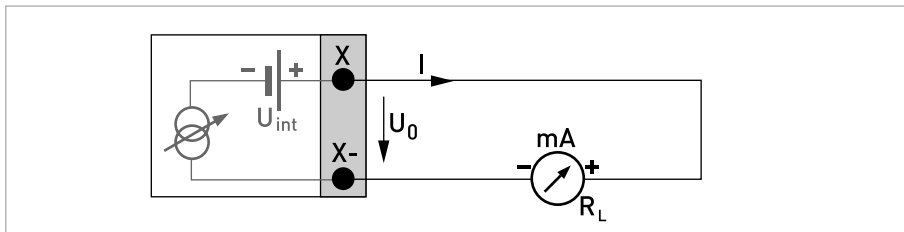


Figure 4-7: Current output active I_a

Current output passive (only current output terminals C/C- have HART[®] capability), modular I/Os

- $U_{\text{ext}} \leq 30 \text{ VDC}$
- $I \leq 22 \text{ mA}$
- $U_0 \geq 1.8 \text{ V}$
- $R_L \leq (U_{\text{ext}} - U_0) / I_{\text{max}}$
- X designates the connection terminals A, B or C, depending on the version of the signal converter.

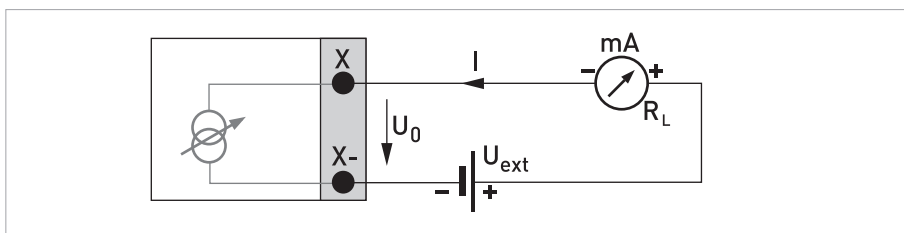


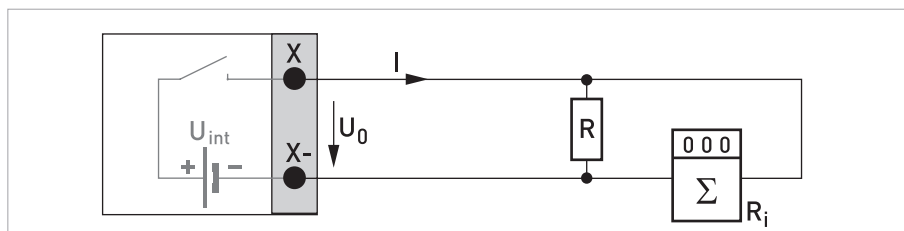
Figure 4-8: Current output passive I_p

**INFORMATION!**

- **Compact and field housing versions:** Shield connected via the cable terminals in the terminal compartment.
- Any connection polarity.

Pulse/frequency output active, modular I/Os

- $U_{nom} = 24 \text{ VDC}$
- f_{max} in the operating menu set to $f_{max} \leq 100 \text{ Hz}$:
 $I \leq 20 \text{ mA}$
 open:
 $I \leq 0.05 \text{ mA}$
 closed:
 $U_{0, nom} = 24 \text{ V at } I = 20 \text{ mA}$
- f_{max} in operating menu set to $100 \text{ Hz} < f_{max} \leq 10 \text{ kHz}$:
 $I \leq 20 \text{ mA}$
 open:
 $I \leq 0.05 \text{ mA}$
 closed:
 $U_{0, nom} = 22.5 \text{ V at } I = 1 \text{ mA}$
 $U_{0, nom} = 21.5 \text{ V at } I = 10 \text{ mA}$
 $U_{0, nom} = 19 \text{ V at } I = 20 \text{ mA}$
- If the following maximum load impedance $R_{L, max}$ is exceeded, the load impedance R_L must be reduced accordingly by parallel connection of R :
 $f \leq 100 \text{ Hz: } R_{L, max} = 47 \text{ k}\Omega$
 $f \leq 1 \text{ kHz: } R_{L, max} = 10 \text{ k}\Omega$
 $f \leq 10 \text{ kHz: } R_{L, max} = 1 \text{ k}\Omega$
- The minimum load impedance $R_{L, min}$ is calculated as follows:
 $R_{L, min} = U_0 / I_{max}$
- X designates the connection terminals A, B or D, depending on the version of the signal converter.

Figure 4-9: Pulse/frequency output active P_a

Pulse/frequency output passive, modular I/Os

- $U_{\text{ext}} \leq 32 \text{ VDC}$
- f_{max} in the operating menu set to $f_{\text{max}} \leq 100 \text{ Hz}$:
 $I \leq 100 \text{ mA}$
 open:
 $I \leq 0.05 \text{ mA}$ at $U_{\text{ext}} = 32 \text{ VDC}$
 closed:
 $U_{0, \text{max}} = 0.2 \text{ V}$ at $I \leq 10 \text{ mA}$
 $U_{0, \text{max}} = 2 \text{ V}$ at $I \leq 100 \text{ mA}$
- f_{max} in operating menu set to $100 \text{ Hz} < f_{\text{max}} \leq 10 \text{ kHz}$:
 open:
 $I \leq 0.05 \text{ mA}$ at $U_{\text{ext}} = 32 \text{ VDC}$
 closed:
 $U_{0, \text{max}} = 1.5 \text{ V}$ at $I \leq 1 \text{ mA}$
 $U_{0, \text{max}} = 2.5 \text{ V}$ at $I \leq 10 \text{ mA}$
 $U_{0, \text{max}} = 5 \text{ V}$ at $I \leq 20 \text{ mA}$
- If the following maximum load impedance $R_{L, \text{max}}$ is exceeded, the load impedance R_L must be reduced accordingly by parallel connection of R :
 $f \leq 100 \text{ Hz}$: $R_{L, \text{max}} = 47 \text{ k}\Omega$
 $f \leq 1 \text{ kHz}$: $R_{L, \text{max}} = 10 \text{ k}\Omega$
 $f \leq 10 \text{ kHz}$: $R_{L, \text{max}} = 1 \text{ k}\Omega$
- The minimum load impedance $R_{L, \text{min}}$ is calculated as follows:
 $R_{L, \text{min}} = (U_{\text{ext}} - U_0) / I_{\text{max}}$
- Can also be set as status output. For the electrical connection refer to status output connection diagram.
- X designates the connection terminals A, B or D, depending on the version of the signal converter.

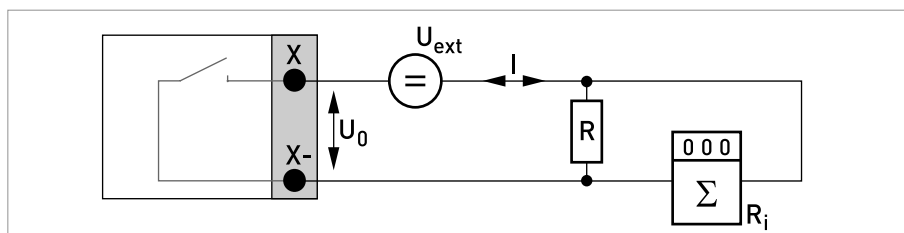


Figure 4-10: Pulse/frequency output passive P_p

**INFORMATION!**

- **Compact and field housing versions:** Shield connected via the cable terminals in the terminal compartment.
- Any connection polarity.

Pulse/frequency output passive P_N NAMUR, modular I/O

- Connection acc. to EN 60947-5-6.
 $U_{\text{ext}} = 8.2 \text{ V} \pm 0.1 \text{ VDC}$
 $R = 1 \text{ k}\Omega \pm 10 \Omega$
- open:
 $I_{\text{nom}} = 0.6 \text{ mA}$
 closed:
 $I_{\text{nom}} = 3.8 \text{ mA}$
- X designates the connection terminals A, B or D, depending on the version of the signal converter.

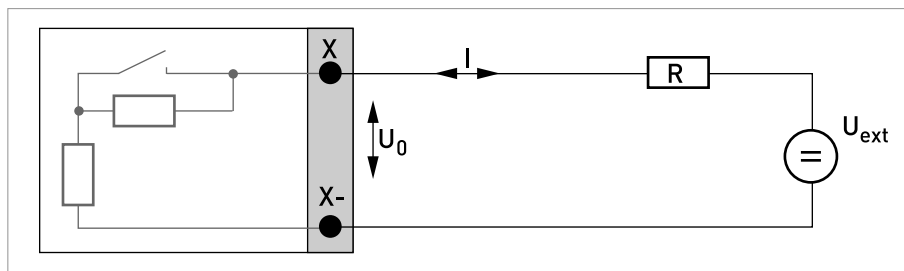


Figure 4-11: Pulse/frequency output passive P_N according to NAMUR EN 60947-5-6

Status output / limit switch active, modular I/Os

- Observe connection polarity.
- $U_{int} = 24 \text{ VDC}$
- $I \leq 20 \text{ mA}$
- $R_L \leq 47 \text{ k}\Omega$
- open:
 $I \leq 0.05 \text{ mA}$
- closed:
 $U_{0, nom} = 24 \text{ V}$ at $I = 20 \text{ mA}$
- X designates the connection terminals A, B or D, depending on the version of the signal converter.

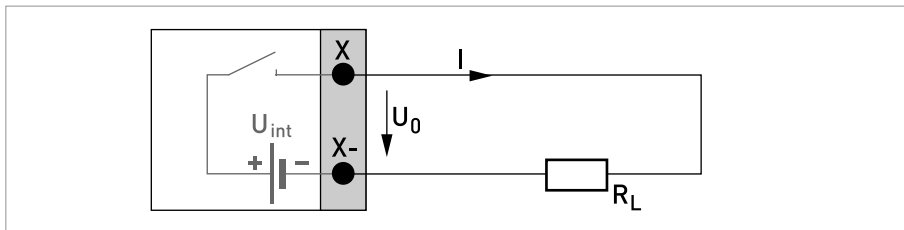


Figure 4-12: Status output / limit switch active S_a

Status output / limit switch passive, modular I/Os

- Any connection polarity.
- $U_{ext} = 32 \text{ VDC}$
- $I \leq 100 \text{ mA}$
- $R_{L, max} = 47 \text{ k}\Omega$
 $R_{L, min} = (U_{ext} - U_0) / I_{max}$
- open:
 $I \leq 0.05 \text{ mA}$ at $U_{ext} = 32 \text{ VDC}$
- closed:
 $U_{0, max} = 0.2 \text{ V}$ at $I \leq 10 \text{ mA}$
 $U_{0, max} = 2 \text{ V}$ at $I \leq 100 \text{ mA}$
- The output is open when the device is de-energised.
- X designates the connection terminals A, B or D, depending on the version of the signal converter.

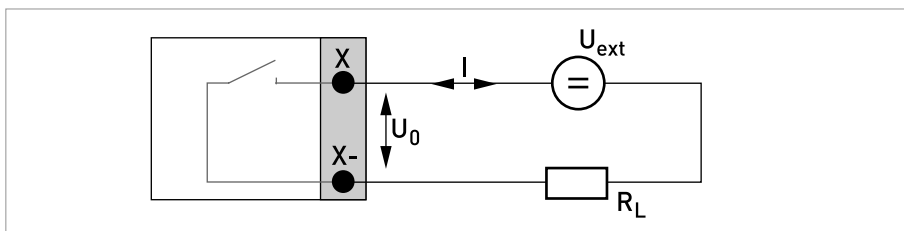


Figure 4-13: Status output / limit switch passive S_p

Status output / limit switch S_N NAMUR, modular I/Os

- Any connection polarity.
- Connection acc. to EN 60947-5-6.
 $U_{\text{ext}} = 8.2 \text{ V} \pm 0.1 \text{ VDC}$
 $R = 1 \text{ k}\Omega \pm 10 \Omega$
- open:
 $I_{\text{nom}} = 0.6 \text{ mA}$
closed:
 $I_{\text{nom}} = 3.8 \text{ mA}$
- The output is open when the device is de-energised.
- X designates the connection terminals A, B or D, depending on the version of the signal converter.

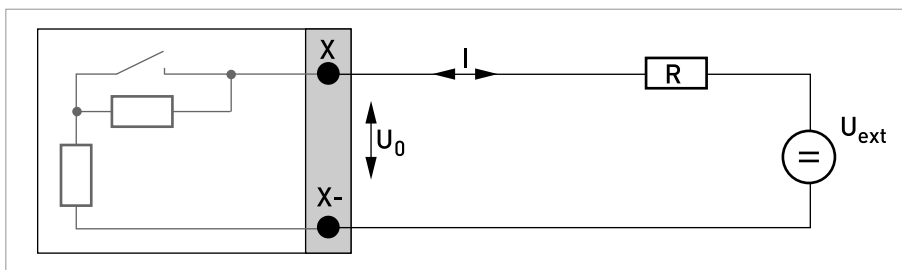


Figure 4-14: Status output / limit switch S_N according to NAMUR EN 60947-5-6

**CAUTION!**

Observe connection polarity.

Control input active, modular I/Os

- $U_{int} = 24 \text{ VDC}$
- External contact open:
 $U_{0, nom} = 22 \text{ V}$
- External contact closed:
 $I_{nom} = 4 \text{ mA}$
- Switching point for identifying "contact open or closed":
Contact closed (on): $U_0 \leq 10 \text{ V}$ at $I_{nom} = 1.9 \text{ mA}$
Contact open (off): $U_0 \geq 12 \text{ V}$ at $I_{nom} = 1.9 \text{ mA}$
- X designates the connection terminals A or B, depending on the version of the signal converter.

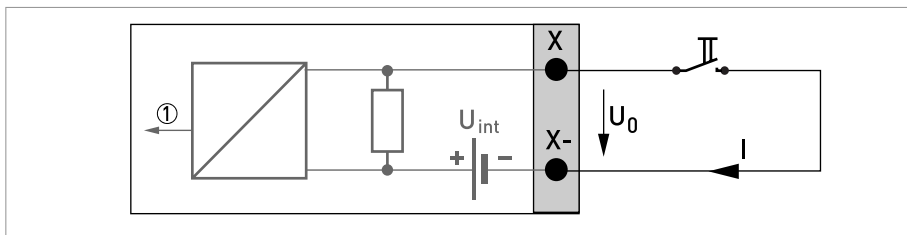


Figure 4-15: Control input active C_a

① Signal

Control input passive, modular I/Os

- $3 \text{ V} \leq U_{ext} \leq 32 \text{ VDC}$
- $I_{max} = 9.5 \text{ mA}$ at $U_{ext} \leq 24 \text{ V}$
 $I_{max} = 9.5 \text{ mA}$ at $U_{ext} \leq 32 \text{ V}$
- Switching point for identifying "contact open or closed":
Contact open (off): $U_0 \leq 2.5 \text{ V}$ at $I_{nom} = 1.9 \text{ mA}$
Contact closed (on): $U_0 \geq 3 \text{ V}$ at $I_{nom} = 1.9 \text{ mA}$
- X designates the connection terminals A or B, depending on the version of the signal converter.

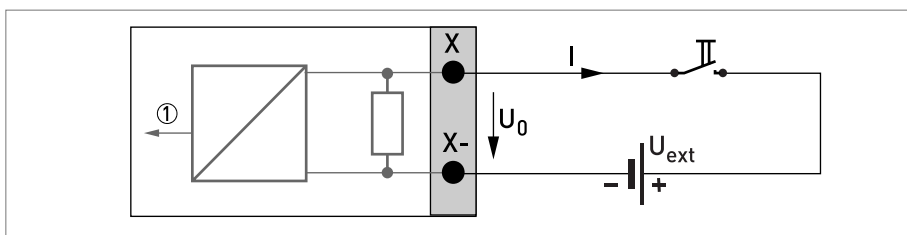


Figure 4-16: Control input passive C_p

① Signal



CAUTION!
Observe connection polarity.

Control input active C_N NAMUR, modular I/Os

- Connection acc. to EN 60947-5-6:
- Switching point for identifying "contact open or closed":
Contact open (off): $U_{0, nom} = 6.3 \text{ V}$ at $I_{nom} < 1.9 \text{ mA}$
Contact closed (on): $U_{0, nom} = 6.3 \text{ V}$ at $I_{nom} > 1.9 \text{ mA}$
- Detection of cable break:
 $U_0 \geq 8.1 \text{ V}$ at $I \leq 0.1 \text{ mA}$
- Detection of cable short circuit:
 $U_0 \leq 1.2 \text{ V}$ at $I \geq 6.7 \text{ mA}$
- X designates the connection terminals A or B, depending on the version of the signal converter.

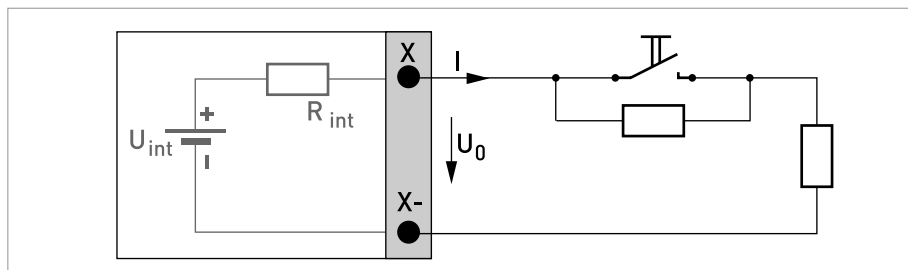


Figure 4-17: Control input active C_N according to NAMUR EN 60947-5-6

4.10.4 Ex i inputs/outputs

**DANGER!**

For devices used in hazardous areas, additional safety notes apply; please refer to the Ex documentation.

**INFORMATION!**

For further information refer to Description of the inputs and outputs on page 35.

Current output active (only current output terminals C/C- have HART[®] capability), Ex i I/Os

- Observe connection polarity.
- $U_{int, nom} = 21 \text{ VDC}$
- $I \leq 22 \text{ mA}$
- $R_L \leq 400 \Omega$
- X designates the connection terminals A or C, depending on the version of the signal converter.

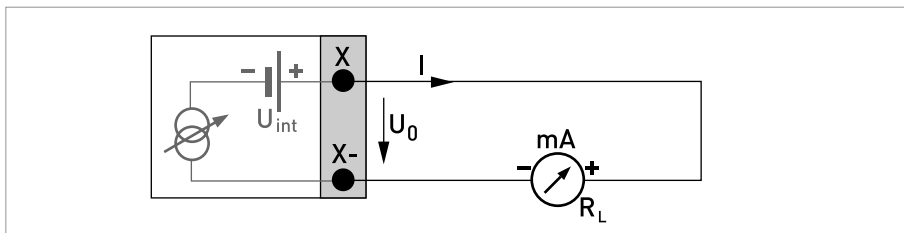


Figure 4-18: Current output active I_a Ex i

Current output passive (only current output terminals C/C- have HART[®] capability), Ex i I/Os

- Any connection polarity.
- $U_{ext} \leq 30 \text{ VDC}$
- $I \leq 22 \text{ mA}$
- $U_0 \geq 4 \text{ V}$
- $R_L \leq (U_{ext} - U_0) / I_{max}$
- X designates the connection terminals A or C, depending on the version of the signal converter.

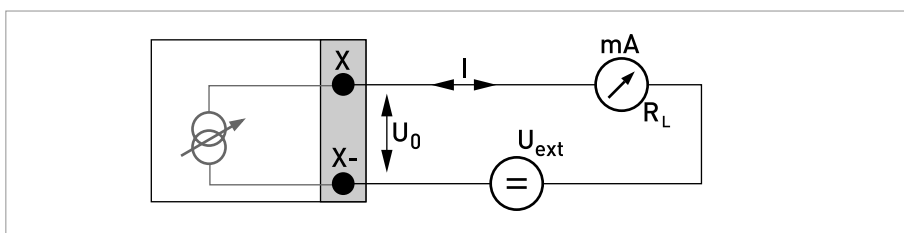


Figure 4-19: Current output passive I_p Ex i

**DANGER!**

For devices used in hazardous areas, additional safety notes apply; please refer to the Ex documentation.

**INFORMATION!**

- **Compact and field housing versions:** Shield connected via the cable terminals in the terminal compartment.
- Any connection polarity.

Pulse/frequency output passive P_N NAMUR, Ex i I/Os

- Connection acc. to EN 60947-5-6.
 $U_{\text{ext}} = 8.2 \text{ V} \pm 0.1 \text{ VDC}$
 $R = 1 \text{ k}\Omega \pm 10 \Omega$
- open:
 $I_{\text{nom}} = 0.43 \text{ mA}$
 closed:
 $I_{\text{nom}} = 4.5 \text{ mA}$
- X designates the connection terminals B or D, depending on the version of the signal converter.

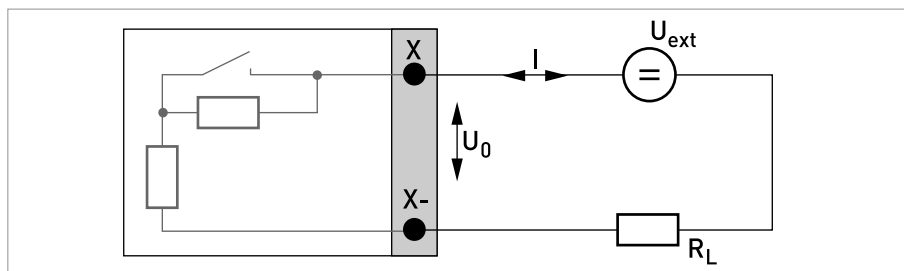


Figure 4-20: Pulse/frequency output passive P_N according to NAMUR EN 60947-5-6 Ex i

**INFORMATION!**

- Any connection polarity.

Status output / limit switch S_N NAMUR, Ex i I/Os

- Connection acc. to EN 60947-5-6.
 $U_{\text{ext}} = 8.2 \text{ V} \pm 0.1 \text{ VDC}$
 $R = 1 \text{ k}\Omega \pm 10 \Omega$
- open:
 $I_{\text{nom}} = 0.43 \text{ mA}$
 closed:
 $I_{\text{nom}} = 4.5 \text{ mA}$
- The output is closed when the device is de-energised.
- X designates the connection terminals B or D, depending on the version of the signal converter.

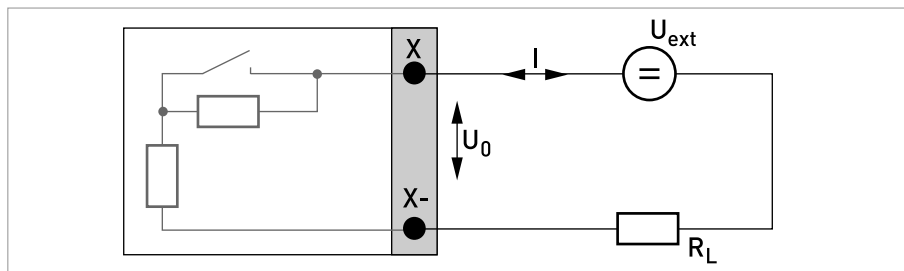


Figure 4-21: Status output / limit switch S_N according to NAMUR EN 60947-5-6 Ex i



DANGER!

For devices used in hazardous areas, additional safety notes apply; please refer to the Ex documentation.



INFORMATION!

- Any connection polarity.

Control input passive, Ex i I/Os

- $5.5\text{ V} \leq U_{\text{ext}} \leq 30\text{ VDC}$
- $I_{\text{max}} = 6\text{ mA}$ at $U_{\text{ext}} \leq 24\text{ V}$
 $I_{\text{max}} = 6.5\text{ mA}$ at $U_{\text{ext}} \leq 32\text{ V}$
- Switching point for identifying "contact open or closed":
 Contact open (off): $U_0 \leq 3.5\text{ V}$ at $I \leq 0.5\text{ mA}$
 Contact closed (on): $U_0 \geq 5.5\text{ V}$ at $I \geq 4\text{ mA}$
- X designates the connection terminals B, if available.

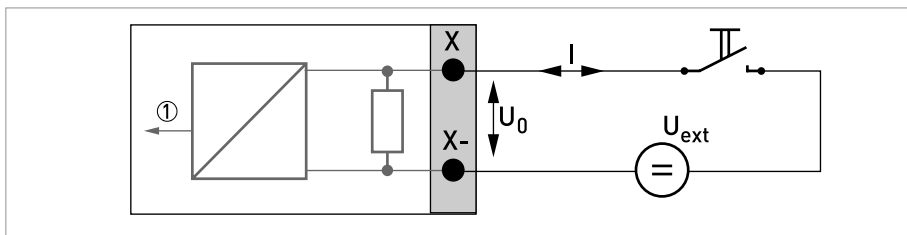


Figure 4-22: Control input passive C_p Ex i

① Signal

4.10.5 HART® connection



INFORMATION!

For modular I/O and Ex i I/O, only the output module for the connection terminals C/C- has HART® capability.

HART® connection active (point-to-point)

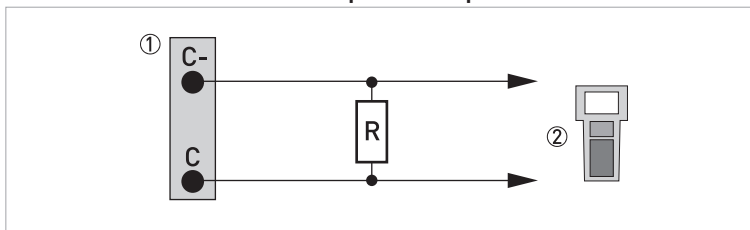
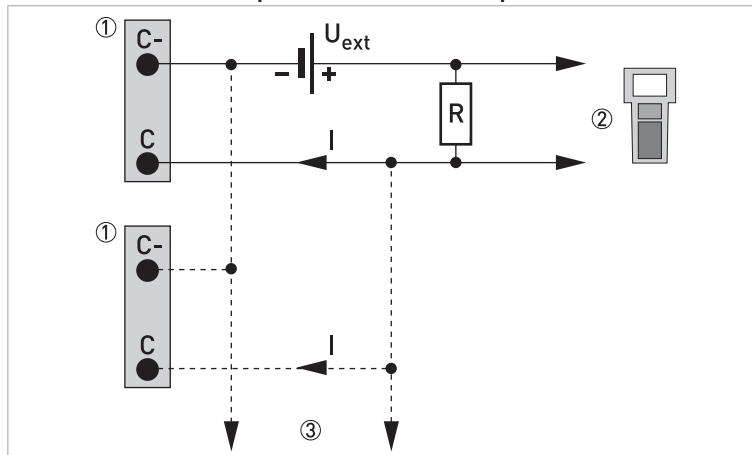


Figure 4-23: HART® connection active (I_a)

- ① Modular I/O: terminals C- and C
- ② HART® communicator

The parallel resistance to the HART® communicator must be $R \geq 230\ \Omega$.

HART[®] connection passive (Multi-Drop mode)Figure 4-24: HART[®] connection passive (I_p)

- ① Modular I/O: terminals C- and C
- ② HART[®] communicator
- ③ Other devices with HART[®] capability

**CAUTION!**

For Multi-Drop mode disable the loop current mode (C4.2).

- $I: I_{0\%} \geq 4 \text{ mA}$
- $U_{ext} \leq 32 \text{ VDC}$
- $R \geq 230 \Omega$

5.1 Switching on the power

Before connecting to power, please check that the system has been correctly installed. This includes:

- The device must be mechanically safe and mounted in compliance with the regulations.
- The power connections must have been made in compliance with the regulations.
- The electrical terminal compartments must be secured and the covers have been screwed on.
- Check that the electrical operating data of the power supply are correct.



- Switching on the power.

5.2 Starting the signal converter

The measuring device, consisting of the flow sensor and the signal converter, is supplied ready for operation. All operating data have been set at the factory in accordance with your order specifications.

When the power is switched on as well as continuously during operation, a self test is carried out. After that the device immediately begins measuring, and the current values are displayed.

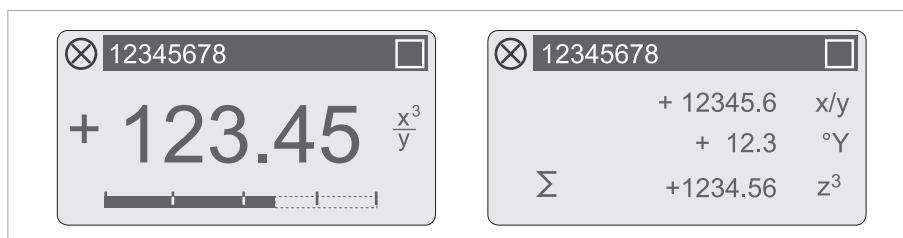


Figure 5-1: Displays in measuring mode (examples for 2 or 3 measured values)
x, y and z denote the units of the measured values displayed

It is possible to change between the two measured value windows, the trend display and a status page containing status messages from continuously running diagnostic functions by pressing the keys \uparrow and \downarrow . For possible status messages, their meaning and cause refer to *Diagnostic information and status messages* on page 106.

6.1 Display and operating elements

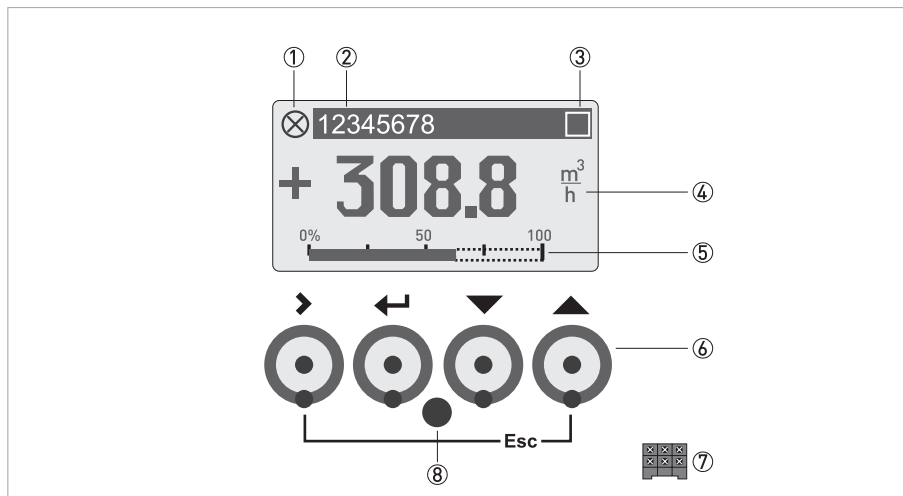


Figure 6-1: Display and operating elements (Example: flow indication with 2 measuring values)

- ① Indicates the device status
- ② Tag number (is only indicated if this number was entered previously by the operator)
- ③ Indicates the key and lock status
- ④ 1st measured variable in large representation
- ⑤ Bargraph indication
- ⑥ Operating keys, optical and mechanical (see table below for function and representation in text)
- ⑦ Interface to the GDC bus (not present in all signal converter versions)
- ⑧ Infrared sensor (not present in all signal converter versions)



INFORMATION!

- The switching point for the 4 optical keys is located directly in front of the glass. It is recommended to activate the keys at right angles to the front. Touching them from the side can cause incorrect operation.
- After 5 minutes of inactivity, there is an automatic return to measuring mode. Previously changed data is not saved.

Key	Measuring mode	Menu mode	Submenu or function mode	Parameter and data mode
>	Switch from measuring mode to menu mode; press key (optical keys for 2.5 s), "A0.0.0 Quick Setup" menu is then displayed	Access to displayed menu, then 1st submenu is displayed	Access to displayed submenu or function	For numerical values, move cursor (highlighted in blue) one position to the right
←	Reset display; "Quick Access" function	Return to measuring mode but prompt whether the data should be saved	Press 1 to 3 times, return to menu mode, data saved	Return to submenu or function, data saved
↓ or ↑	Switch between display pages: measured value 1 + 2, trend page and status page	Select menu	Select submenu or function	Use cursor highlighted in blue to change number, unit, property and to move the decimal point
Esc (> + ↑)	-	-	Return to menu mode without acceptance of data	Return to submenu or function without acceptance of data

Table 6-1: Description of functionality of operating keys








Icon	Description
	Optical or mechanical key pressed
	Optical keys disabled (only displayed while pressed)
	Lock jumper set
	Device in SIL mode (unverified safe configuration)
	Device in SIL mode (verified locked safe configuration)
	Infrared interface enabled
	Configuration checked and stored

Table 6-2: Indication of key and lock status

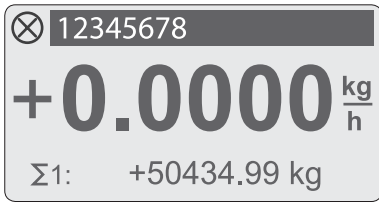

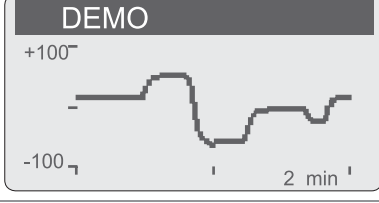
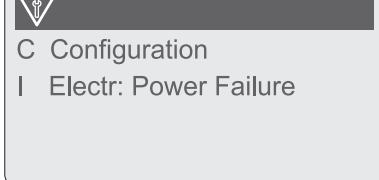
Name	Screen	Display in menu mode
1st measuring page		Menu for device configuration
2nd measuring page		Menu for device configuration
Graphic page		Menu for device configuration
Status message page		Menu for status messages with detailed status information

Table 6-3: Indication of display pages

6.1.1 Display in measuring mode with 2 or 3 measured values

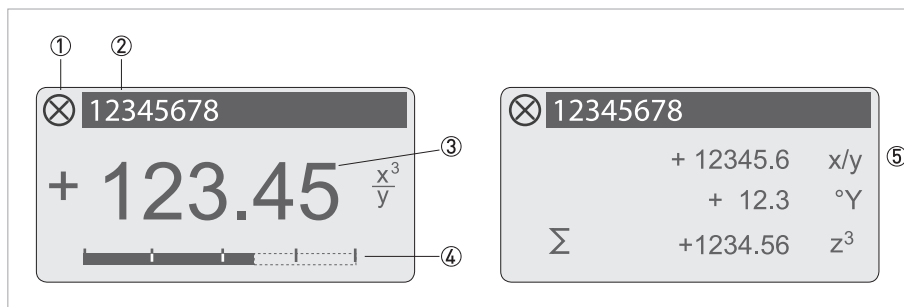


Figure 6-2: Example for display in measuring mode with 2 or 3 measured values

- ① Indicates a possible status message in the status list
- ② Tag number (is only indicated if this number was entered previously by the operator)
- ③ 1st measured variable in large representation
- ④ Bargraph indication
- ⑤ Depiction with 3 measured values

6.1.2 Display for selection of submenu and functions, 3 lines

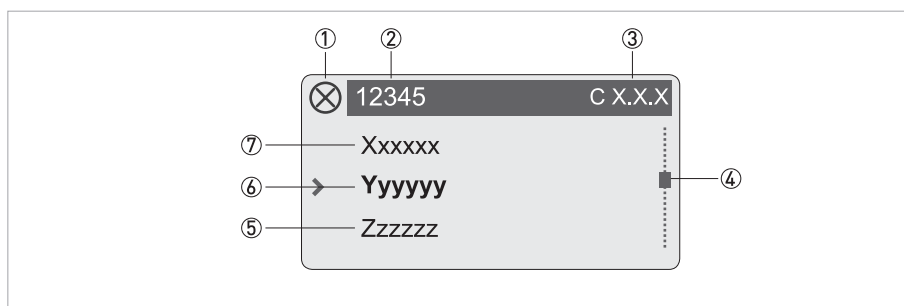


Figure 6-3: Display for selection of submenu and functions, 3 lines

- ① Indicates a possible status message in the status list
- ② Menu, submenu or function name
- ③ Number relating to ⑥
- ④ Indicates position within menu, submenu or function list
- ⑤ Next menu(s), submenu or function
[___ signals in this line the end of the list]
- ⑥ Current menu(s), submenu or function
- ⑦ Previous menu(s), submenu or function
[___ signals in this line the beginning of the list]

6.1.3 Display when setting parameters, 4 lines

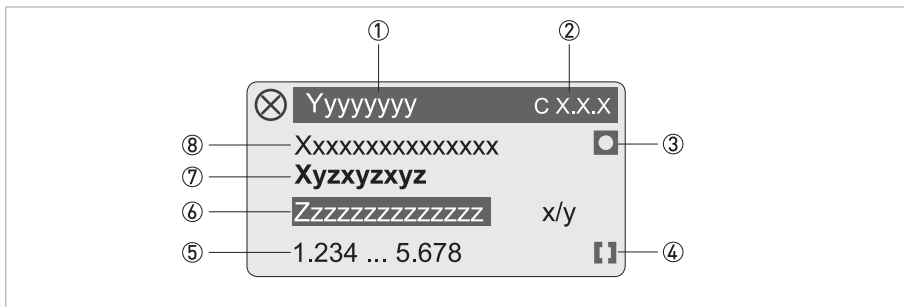


Figure 6-4: Display when setting parameters, 4 lines

- ① Current menu(s), submenu or function
- ② Number relating to ⑦
- ③ Denotes factory setting
- ④ Denotes permissible value range
- ⑤ Permissible value range for numeric values
- ⑥ Currently set value, unit or function (when selected, appears with white text, blue background)
This is where the data is changed.
- ⑦ Current parameter
- ⑧ Factory setting of parameter

6.1.4 Display when previewing parameters, 4 lines

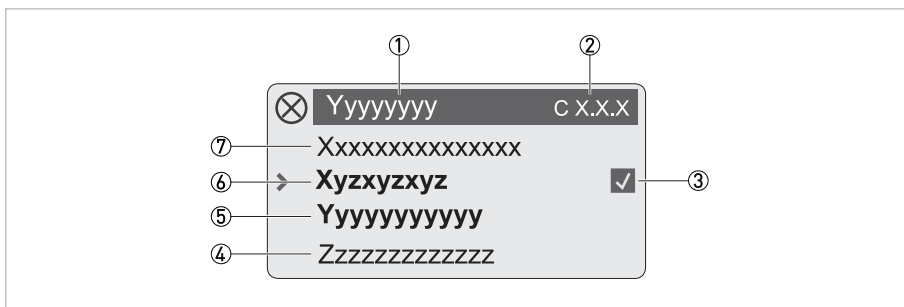


Figure 6-5: Display when previewing parameters, 4 lines

- ① Current menu(s), submenu or function
- ② Number relating to ⑥
- ③ Denotes the status of the parameter
- ④ Next parameter
- ⑤ Currently set data from ⑥
- ⑥ Current parameter [for selection press key >; then see previous chapter]
- ⑦ Factory setting of parameter

Icon	Description
	Changed parameter
	Factory parameter (not changeable)
	Lock parameter by write access authentication
	Lock parameter by jumper or SIL Mode

Table 6-4: Description of parameter icons

6.1.5 Using an IR interface (option)

The optical IR interface serves as an adapter for PC-based communication with the signal converter without opening the housing.



INFORMATION!

- *This option is not part of the scope of delivery.*
- *For more information about activation refer to function description of C6.4.3.*

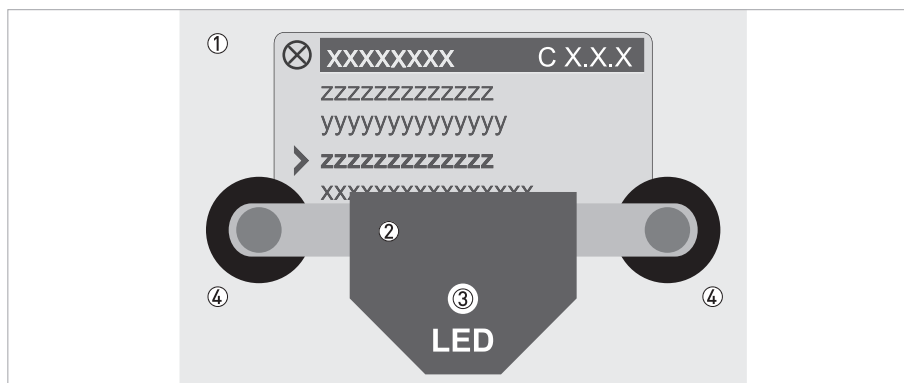


Figure 6-6: IR interface

- ① Glass panel in front of the control and display panel
- ② IR interface
- ③ LED lights up when IR interface is activated.
- ④ Suction cups

Timeout function

Following activation of the IR interface in Fct. C6.4.3 the interface must be properly positioned and attached to the housing with the suction cups within 60 seconds. If this does not happen within the specified time period, the device can be operated using the optical keys again. Upon activation, the LED ③ lights up and the optical keys no longer function.

6.2 Menu structure

Menu "Quick Setup"

A0.0.0 Quick Setup	
	A1.0.0 Language
	A2.0.0 Reset
	A2.1.0 Reset Errors
	A2.2.0 Stop all Simulations
	A2.3.0 All Totalisers
	A2.4.0 Totaliser 1
	A2.5.0 Totaliser 2
	A2.6.0 Totaliser 3
	A3.0.0 Configuration
	A3.1.0 Tag
	A3.2.0 Measurement
	A3.3.0 Range
	A3.4.0 Alarm Code
	A3.5.0 Low Flow Cutoff
	A3.6.0 Damping
	A3.7.0 Terminals C Type
	A3.8.0 Flow Direction
	A4.0.0 Safety Mode
	A5.0.0 SIL Verification
	A6.0.0 Unlock Device
	A7.0.0 Calibrate Zero
	A8.0.0 Operation Mode

Menu "Test"

B0.0.0 Test	
	B1.0.0 Status
	B1.1.0 Status Log
	B1.2.0 Change Log
	B1.3.0 Zero Calibration Log
	B1.4.0 Last Density Calib.
	B1.5.0 Act. Operat. Mode
	B1.6.0 Safety State
	B2.0.0 Actual Values
	B2.1.0 Operating Hours
	B2.2.0 Date and Time
	B2.3.0 Mass Flow
	B2.4.0 Volume Flow
	B2.5.0 Velocity
	B2.6.0 Density
	B2.7.0 Temperature
	B2.8.0 Strain 1
	B2.9.0 Strain 2
	B2.10.0 Tube Frequency
	B2.11.0 Drive Level
	B2.12.0 Sensor A Level
	B2.13.0 Sensor B Level
	B2.14.0 2 Phase Signal
	B2.15.0 Electronics Temp.
	B3.0.0 Simulation
	B3.1.0 Stop All Simulations
	B3.2.0 Mass Flow
	B3.3.0 Volume Flow
	B3.4.0 Density
	B3.5.0 Temperature
	B3.6.0 Status
	B3.7.0 IO A (dep. on output type of terminals A)
	B3.8.0 IO B (dep. on output type of terminals B)
	B3.9.0 IO C (dep. on output type of terminals C)
	B3.10.0 IO D (dep. on output type of terminals D)

B4.0.0 Sensor Information	
	B4.1.0 Sensor Type
	B4.2.0 Sensor ID
	B4.3.0 Sensor Serial No.
	B4.4.0 V No. Sensor
	B4.5.0 Sensor Revision
	B4.6.0 Nominal Mass Flow
	B4.7.0 Max. Allowed Temp.
	B4.8.0 Min. Allowed Temp.
	B4.9.0 Max. Rec. Temp.
	B4.10.0 Min. Rec. Temp.
	B4.11.0 Calibration Date
	B4.12.0 Flow Calibration
	B4.13.0 Density Calibration
B5.0.0 Electr. Information	
	B5.1.0 C Number
	B5.2.0 Sensor Electronics
	B5.3.0 HART
	B5.4.0 V No. Converter
	B5.5.0 Electronic Revision

Menu "Setup"

C0.0.0 Setup	
C1.0.0 Process Input	
	C1.1.0 Flow
	C1.2.0 Density
	C1.3.0 Concentration
	C1.4.0 System Control*
	C1.5.0 Diagnostics
C2.0.0 I/O	
	C2.1.0 Hardware
	C2.2.0 Terminals A
	C2.3.0 Terminals B
	C2.4.0 Terminals C
	C2.5.0 Terminals D
C3.0.0 Totalisers	
	C3.1.0 Totaliser 1
	C3.2.0 Totaliser 2
	C3.3.0 Totaliser 3
C4.0.0 HART	
	C4.1.0 HART
	C4.2.0 Loop Current Mode
	C4.3.0 Identification
	C4.4.0 HART Dyn. Variables

C5.0.0 Display	
	C5.1.0 Language
	C5.2.0 Contrast
	C5.3.0 Optical Keys
	C5.4.0 Backlight
	C5.5.0 Default Display
	C5.6.0 1st Meas. Page
	C5.7.0 2nd Meas. Page
	C5.8.0 Graphic Page
C6.0.0 Device	
	C6.1.0 Tag
	C6.2.0 Reset Errors
	C6.3.0 Config. Management
	C6.4.0 Special Functions
	C6.5.0 Units
	C6.6.0 Status Groups
C7.0.0 SIL**	
	C7.1.0 Configuration
	C7.2.0 Safety Mode
	C7.3.0 SIL Verification
	C7.4.0 Unlock Device
	C7.5.0 Unlock Password

* only available if expert mode is enabled

** only available in device variants certified according to IEC 61508

6.3 Function tables



INFORMATION!

- The following tables describe the functions of the standard device with HART[®] connection. The functions for Modbus, Foundation Fieldbus, Profibus and Profinet IO are described in detail in the corresponding supplementary instructions.
- Depending on the device version, not all functions are available.
- The device provides an expert mode. Some functions marked with * are only available in expert mode.

6.3.1 Menu "Quick Setup"

Function	Description and selection
A0.0.0 Quick Setup	
A1.0.0 Language	Select language. Available languages: English, German, French, Danish, Spanish, Italian, Dutch, Polish, Portuguese, Swedish, Turkish
A2.0.0 Reset	
A2.1.0 Reset Errors	Reset Errors? Select: No / Yes
A2.2.0 Stop all Simulations	Stop all running simulations? Select: No / Yes
A2.3.0 All Totalisers	Reset all Totalisers? Select: No / Yes
A2.4.0 Totaliser 1	Reset Totaliser 1? Select: No / Yes
A2.5.0 Totaliser 2	Reset Totaliser 2? Select: No / Yes
A2.6.0 Totaliser 3	Reset Totaliser 3? Select: No / Yes
A3.0.0 Configuration	
Safety relevant parameters for SIL setup.	
A3.1.0 Tag	Measuring point identifier [Tag no.] (also for HART [®] operation) will be displayed in the LCD header (max. 8 digits).
A3.2.0 Measurement	Measurement value for current output at terminals C. Select: Flow Velocity / Volume Flow / Mass Flow / Temperature / Density / Sensor Average / Sensor Deviation / Drive Level / Tube Frequency / Strain 1 / Strain 2 / 2 Phase Signal Depending on the settings for the concentration measurement, the following measurements are possible: Concentration 1 / Concentration 2 / Conc. mass flow 1 / Conc. mass flow 2 / Conc. volume flow 1 / Conc. volume flow 2
A3.3.0 Range	Range setting for current output. Selection depends on the measurement value.
A3.4.0 Alarm Code	Specify the failure current output. Select: Low (3.5 mA) / High (21.5 mA)
A3.5.0 Low Flow Cutoff	Sets the measurement to "0" for low values. x.xxx ± x.xxx%; range: 0.0...20% [1st value = switching point / 2nd value = hysteresis]; condition: 2nd value ≤ 1st value

Function	Description and selection
A3.6.0 Damping	Setting for the current output. Range: 0.0...100 s
A3.7.0 Terminals C Type	Select: Passive / Active
A3.8.0 Flow Direction	Defines polarity of flow direction. Select: Forwards (acc. to the arrow on the flow sensor) / Backwards (in the opposite direction of the arrow)
A4.0.0 Safety Mode	Select: non-SIL Mode / SIL Mode (only available in non expert mode)
A5.0.0 SIL Verification	Verification of safety relevant parameters and lock of the device. For detailed information refer to the "Safety manual". Note: Only available if "Safety Mode" is changed!
A6.0.0 Unlock Device	Unlock device. For detailed information refer to the "Safety manual".
A7.0.0 Calibrate Zero	Perform zero calibration. Query: Calibrate zero? Select: Automatic / Factory Calibration / Manual (display last value; set new value; range: -10...+10%) / Cancel (return without calibration)
A8.0.0 Operation Mode	Sets the operating mode. Select: Measuring / Standby / Stop

6.3.2 Menu "Test"

Function	Description and selection
B0.0.0 Test	
B1.0.0 Status	Information
B1.1.0 Status Log	Log with date and time of status messages that occurred.
B1.2.0 Change Log	Shows the changes including date, time and check sum for all settings and parameters in the signal converter, regardless of the interface (display, HART®, PROFIBUS,...) used. The check sum across all settings is displayed directly below the menu item.
B1.3.0 Zero Calibration Log	Displays history of zero calibrations performed. Showing zero point, temperature, date and time.
B1.4.0 Last Density Calib.	Displays date of last density calibration (yyyy-mmm-ddd).
B1.5.0 Act. Operat. Mode	Displays the current operating mode.
B1.6.0 Safety State	Displays current state of functional safety configuration (only for SIL device).
B2.0.0 Actual Values	
B2.1.0 Operating Hours	Displays the operating hours of the device.
B2.2.0 Date and Time	Displays date and time.
B2.3.0 Mass Flow	Displays current unfiltered mass flow.
B2.4.0 Volume Flow	Displays current unfiltered volume flow.
B2.5.0 Velocity	Displays current unfiltered flow velocity.
B2.6.0 Density	Displays current unfiltered density.
B2.7.0 Temperature	Displays current unfiltered temperature.
B2.8.0 Strain 1	Displays current value for the first strain.
B2.9.0 Strain 2	Displays current value for the second strain.
B2.10.0 Tube Frequency	Displays current vibration frequency of the measuring tube.
B2.11.0 Drive Level	Displays current drive level to activate vibration.
B2.12.0 Sensor A Level	Displays current vibration amplitude of "Sensor A".
B2.13.0 Sensor B Level	Displays current vibration amplitude of "Sensor B".
B2.14.0 2 Phase Signal	Displays current 2-phase indicator value.
B2.15.0 Electronics Temp.	Displays current temperature of the sensor electronics.
B3.0.0 Simulation	Displayed values are simulated.
B3.1.0 Stop All Simulations	Stop all running simulations. Select: No / Yes
B3.2.0 Mass Flow	Simulation of mass flow. Set value (set simulated value in kg/h). Query: Start Simulation? Select: Yes (start simulation) / Stop Simulation (stop simulation of mass flow) / Cancel (exit function without simulation)
B3.3.0 Volume Flow	Simulation of volume flow. Set value (set simulated value in L/h). Query: Start Simulation? Select: Yes (start simulation) / Stop Simulation (stop simulation of volume flow) / Cancel (exit function without simulation)

Function	Description and selection
B3.4.0 Density	Simulation of density. Set value (set simulated value in kg/m ³). Query: Start Simulation? Select: Yes (start simulation) / Stop Simulation (stop simulation of density) / Cancel (exit function without simulation)
B3.5.0 Temperature	Simulation of temperature. Set value (set simulated value in °C). Query: Start Simulation? Select: Yes (start simulation) / Stop Simulation (stop simulation of temperature) / Cancel (exit function without simulation)
B3.6.0 Status	Simulation of device status and process value status. Set value (select: Failure / Out of Specification / Maintenance Required / Function Check) Query: Start Simulation? Select: Yes (start simulation) / Stop Simulation (stop simulation of status) / Cancel (exit function without simulation)
B3.7.0 IO A	Sets simulated value of output on terminals A.
B3.8.0 IO B	Sets simulated value of output on terminals B.
B3.9.0 IO C	Sets simulated value of output on terminals C.
B3.10.0 IO D	Sets simulated value of output on terminals D.
B4.0.0 Sensor Information	
B4.1.0 Sensor Type	Displays the flow sensor type.
B4.2.0 Sensor ID	Displays the identification number of the flow sensor.
B4.3.0 Sensor Serial No.	Displays the serial number of the flow sensor.
B4.4.0 V No. Sensor	Displays the order number of the flow sensor.
B4.5.0 Sensor Revision	Displays information of the flow sensor revision.
B4.6.0 Nominal Mass Flow	Displays the nominal mass flow of the flow sensor.
B4.7.0 Max. Allowed Temp.	Displays the maximum permitted temperature for the flow sensor.
B4.8.0 Min. Allowed Temp.	Displays the minimum permitted temperature for the flow sensor.
B4.9.0 Max. Rec. Temp.	Displays the maximum recorded flow sensor temperature whilst powered.
B4.10.0 Min. Rec. Temp.	Displays the minimum recorded flow sensor temperature whilst powered.
B4.11.0 Calibration Date	Displays the date of calibration of the flow sensor.
B4.12.0 Flow Calibration	Displays the flow calibration coefficients (CF): CF1...CF27
B4.13.0 Density Calibration	Displays the flow sensor density calibration coefficient (DCF): DCF1...DCF8
B5.0.0 Electr. Information	
B5.1.0 C Number	Displays the C number of the installed electronics.
B5.2.0 Sensor Electronics	Displays information of the sensor electronics PCB.
B5.3.0 Profibus / Foundation Fieldbus / Modbus	Displays information of the Profibus interface or Foundation Fieldbus or RS 485 / Modbus interface.
B5.4.0 V No. Converter	Displays the order number of the electronics.
B5.5.0 Electronic Revision	Displays the electronic revision (ER) of the electronics.

6.3.3 Menu "Setup"

Function	Description and selection
C0.0.0 Setup	
C1.0.0 Process Input	
C1.1.0 Flow	
C1.1.1 Calibrate Zero	Performs zero calibration. Query: Calibrate zero? Select: Automatic / Factory Calibration / Manual (display last value; set new value; range: -10...+10%) / Cancel (return without calibration)
C1.1.2 Zero Add. Offset*	Direct setting of zero offset. Note: Only available if expert mode in C6.4.5 is enabled!
C1.1.3 Flow Correction*	Defines additional correction for mass flow. Range: -100.00...+100.00% Note: Only available if expert mode in C6.4.5 is enabled!
C1.1.4 Flow Direction	Defines polarity of flow direction. Select: Forwards (acc. to the arrow on the flow sensor) / Backwards (in the opposite direction of the arrow)
C1.1.5 Process Noise Damping*	Sets process noise damping. Range: 0.01...30.00 s Note: Only available if expert mode in C6.4.5 is enabled!
C1.1.6 Low Flow Cutoff*	Sets the measurement to "0" for low values. x.xxx ± x.xxx%; range: 0.0...20% (1st value = switching point / 2nd value = hysteresis); condition: 2nd value ≤ 1st value Note: Only available if expert mode in C6.4.5 is enabled!
C1.1.7 Press. Supp. Cutoff*	Low flow cutoff settings for the pressure suppression. Range: 0.0...10.0% Note: Only available if expert mode in C6.4.5 is enabled!
C1.1.8 Press. Supp. Time*	Sets the pressure suppression time. Range: 0.0...20.0 s Note: Only available if expert mode in C6.4.5 is enabled!
C1.1.9 Pipe Diameter	Sets the pipe diameter in mm to calculate the flow velocity. Range: 1.00...500.00 mm
C1.2.0 Density	
C1.2.1 Calibrate Density	Starts density calibration. Select: 1 Point Calibration / 2nd Calibration Point / Factory Calibration / Cancel For detailed information refer to <i>Density calibration (C1.2.1 Calibrate Density)</i> on page 89.
C1.2.2 Density Mode	Selection of density mode. Select: Process / Fixed [a fixed value is used for the density (e.g. standard density)] / Referred [calculates process density based on a reference temperature] / Standard [calculates standard density based on a reference temperature and the correction factors]
C1.2.3 Fixed Density Value	Sets the fixed value (e.g. standard density) for the density. Available only if density mode "Fixed" has been selected in C1.2.2.
C1.2.4 Ref. Density Temp	Sets the reference temperature for the reference density option. Available only if density mode "Referred" has been selected in C1.2.2.

Function	Description and selection
C1.2.5 Ref. Density Slope	Sets the slope for the reference density option. Range: 0.0...65.00 Available only if density mode "Referred" has been selected in C1.2.2.
C1.2.6 Standard Density Temp.	Density reference temperature to calculate standard density. Available only if density mode "Standard" has been selected in C1.2.2.
C1.2.7 Standard Density k0	Coefficient k_0 to calculate standard density. Range: 0.0...5000.00 Available only if density mode "Standard" has been selected in C1.2.2.
C1.2.8 Standard Density k1	Coefficient k_1 to calculate standard density. Range: -100.00...100.00 Available only if density mode "Standard" has been selected in C1.2.2.
C1.2.9 Standard Density k2	Coefficient k_2 to calculate standard density. Range: -10.0...10.00 Available only if density mode "Standard" has been selected in C1.2.2.
C1.3.0 Concentration	For further information refer to supplementary concentration manual.
C1.3.1 Conc. Data Sel.	Defines which set of general concentration parameters are active. Select: Conc. Data 1 / Conc. Data 2
C1.3.2 Concentration 1	Defines the function of the concentration measurement.
C1.3.2 Conc. Function	Sets the required concentration measurement. Select: Off / Brix / % Mass / % Volume / Baume 144 / Baume 145 / % NaOH / Plato / API / % Alcohol by mass / % Alcohol by volume
C1.3.2 Conc. Offset	Sets an additional offset for the concentration measurement. Can be used to correct for differences between the measured value and the reference value. Range: -100.00...+100.00%
C1.3.2 Conc. Product	Defines which general concentration product is displayed. Select: % Of Product A / % Of Product B
C1.3.3 Concentration 2	Defines the function of the concentration measurement.
C1.3.3 Conc. Function	Sets the required concentration measurement. Select: Off / Brix / % Mass / % Volume / Baume 144 / Baume 145 / %NaOH / Plato / API / % Alcohol by mass / % Alcohol by volume
C1.3.3 Conc. Offset	Sets an additional offset for the concentration measurement. Can be used to correct for differences between the measured value and the reference value. Range: -100.00...+100.00%
C1.3.3 Conc. Product	Defines which general concentration product is displayed. Select: % Of Product A / % Of Product B
C1.3.4 Conc. Data 1	Defines the concentration coefficients used for concentration parameter sets 1 & 2.
C1.3.4 CCF01	Defines the use of linear or non-linear coefficients to measure concentration. Select: Linear / Non Linear
C1.3.4 CCF02	Density of "Product A" in g/cm^3 .
C1.3.4 CCF03	Temperature coefficient for "Product A".
C1.3.4 CCF04	Temperature coefficient squared for "Product A".
C1.3.4 CCF05	Defines "Product B" type. Select: Pure Water / Town Water / Other
C1.3.4 CCF06	Density of "Product B" in g/cm^3 (if CCF05 = Other).
C1.3.4 CCF07	Temperature coefficient squared for "Product B" (if CCF05 = Other).
C1.3.4 CCF08	Defines non-linear equation if CCF01 is set to "Non Linear".
C1.3.4 CCF09	Defines non-linear equation if CCF01 is set to "Non Linear". Consult the manufacturer for settings.

Function	Description and selection
C1.3.4 CCF10	Defines non-linear equation if CCF01 is set to "Non Linear". Consult the manufacturer for settings.
C1.3.4 CCF11	Defines non-linear equation if CCF01 is set to "Non Linear". Consult the manufacturer for settings.
C1.3.4 CCF12	Defines non-linear equation if CCF01 is set to "Non Linear". Consult the manufacturer for settings.
C1.3.5 Conc. Data 2	Defines the concentration coefficients used for concentration parameter sets 1 & 2.
C1.3.5 CCF01	Defines the use of linear or non-linear coefficients to measure concentration. Select: Linear / Non Linear
C1.3.5 CCF02	Density of product A in g/cm ³ .
C1.3.5 CCF03	Temperature coefficient for "Product A".
C1.3.5 CCF04	Temperature coefficient squared for "Product A".
C1.3.5 CCF05	Defines "Product B" type. Select: Pure Water / Town Water / Other
C1.3.5 CCF06	Density of "Product B" in in g/cm ³ (if CCF05 = Other).
C1.3.5 CCF07	Temperature coefficient squared for "Product B" (if CCF05 = Other).
C1.3.5 CCF08	Defines non-linear equation if CCF01 is set to "Non Linear".
C1.3.5 CCF09	Defines non-linear equation if CCF01 is set to "Non Linear". Consult the manufacturer for settings.
C1.3.5 CCF10	
C1.3.5 CCF11	
C1.3.5 CCF12	
C1.4.0 System Control*	
C1.4.1 Function*	Sets the system control action. Select: Inactive (off) / Flow = 0 (flow to zero) Note: Only available if expert mode in C6.4.5 is enabled!
C1.4.2 Condition*	Sets the condition for activating the system control. Select: Density / Temperature Note: Only available if expert mode in C6.4.5 is enabled!
C1.4.3 Max. Temperature/Density*	Defines the upper limit for the condition selected in C1.4.2. Note: Only available if expert mode in C6.4.5 is enabled!
C1.4.3 Min. Temperature/Density*	Defines the lower limit for the condition selected in C1.4.2. Note: Only available if expert mode in C6.4.5 is enabled!
C1.5.0 Diagnostics	
C1.5.1 2 Phase Threshold	Sets the process-dependent threshold of the 2 phase signal error message. Range: 0.0...1000.0
C1.5.2 Diagnosis 1	Defines the parameter for the respective diagnosis value. Select: Disabled (goes to zero) / Sensor Average (sensor amplitude A+B) / Sensor Deviation / Drive Level / Tube Frequency / Strain 1 / Strain 2 / 2 Phase Signal
C1.5.3 Diagnosis 2	

Function	Description and selection
C2.0.0 I/O	
C2.1.0 Hardware	Configuration of connection terminals. Selection depends on signal converter version.
C2.1.1 Terminals A	Select: Off (switched off) / Current Output / Frequency Output / Pulse Output / Status Output / Limit Switch / Control Input
C2.1.3 Terminals B	Select: Off (switched off) / Current Output / Frequency Output / Pulse Output / Status Output / Limit Switch / Control Input
C2.1.5 Terminals C	Select: Off (switched off) / Current Output
C2.1.6 Terminals C Type	Select: Passive / Active
C2.1.7 Terminals D	Select: Off (switched off) / Frequency Output / Pulse Output / Status Output / Limit Switch
C2.1.8 Terminals D Type	Select: Active / Passive / NAMUR
C2._0 Current Out X	X represents one of the connection terminals A, B or C. _ represents: 1 = Terminals A, 2 = Terminals B, 3 = Terminals C
C2._1 Measurement	Measurement value for current output on terminals X. Select: Flow Velocity / Volume Flow / Mass Flow / Temperature / Density / Sensor Average / Sensor Deviation / Drive Level / Tube Frequency / Strain 1 / Strain 2 / 2 Phase Signal Depending on the settings for the concentration measurement, the following measurements are possible: Concentration 1 / Concentration 2 / Conc. mass flow 1 / Conc. mass flow 2 / Conc. volume flow 1 / Conc. volume flow 2
C2._2 Range	0...100% of the measurement value set in C2._1. x.xx...xx.xx __ _ (format and unit depend on the measurement value)
C2._3 Low Flow Cutoff	Sets the measurement to "0" for low values. x.xxx ± x.xxx%; range: 0.0...20% (1st value = switching point / 2nd value = hysteresis); condition: 2nd value ≤ 1st value
C2._4 Damping	Setting for the current output. Range: 0.0...100 s
C2._5 Polarity	Sets polarity; the flow direction in C1.1.4 must be considered! Select: Both Polarities (plus and minus values are displayed) / Positive Polarity (display for negative values = 0) / Negative Polarity (display for positive values = 0) / Absolute Value (displayed value is positive for both negative and positive measurement values) Note: Only available if expert mode in C6.4.5 is enabled!
C2._6 Current Span	Sets the current values that are used to represent the measurement value. Select: 4-20 mA / Custom (can be specified in C2._7)
C2._7 Range 0%...100%	HART® current output: 4...20 mA Current range for the selected measurement, e.g. 4...20 mA, corresponds to 0...100% Note: with a 0...20 mA current output, "HART" in C4.1.0 must be switched off! xx.x...xx.x mA; range: 4.00...20 mA (Condition: 4 mA ≤ 1st value ≤ 2nd value ≤ 20 mA) Note: Only available if "Custom" is selected for "Current Span" in C2._6! HART® is only available on "Terminals C"!
C2._8 Extended Range	Min. and max. limits of current values. If the current range is exceeded, the current is set to these limits. xx.x...xx.x mA; range: 03.5...21.5 mA (Condition: 0 mA ≤ 1st value ≤ 2nd value ≤ 21.5 mA and out of current range)

Function	Description and selection
C2._.9 Alarm Code	Specify the failure current output. Select: Low (3.5 mA) / High (21.5 mA) (if "4-20 mA" is selected for "Current Span") Range: 3.0...22.0 mA (if "Custom" is selected for "Current Span")
C2._.10 Alarm Condition	Sets the condition that triggers an alarm. Select: Safety Rel. Failures / Failure / Out of Specification
C2._.11 Special Function*	Automatic range Select: Off (switched off) / Automatic Range (range is changed automatically; extended lower range, only makes sense in combination with a status output) / External Range (change by control input, extended lower range; control input must also be activated) Note: Only available if expert mode in C6.4.5 is enabled!
C2._.12 Threshold*	Available only when C2._.11 is activated. Defines the threshold between extended and normal range. The automatic range function always changes from the extended to the normal range when the 100% current is reached. The upper 100% value of the hysteresis is then = 0. The threshold is then the hysteresis value, instead of "Threshold ± Hysteresis" as shown in the display. Range: 5.0...80% (1st value = switching point / 2nd value = hysteresis), condition: 2nd value ≤ 1st value Note: Only available if expert mode in C6.4.5 is enabled!
C2._.13 4mA Trimming*	Trimming of the current at 4 mA. Reset to 4 mA restores the factory calibration. Used for HART® setting. Note: Only available if expert mode in C6.4.5 is enabled!
C2._.14 20mA Trimming*	Trimming of the current at 20 mA. Reset to 20 mA restores the factory calibration. Used for HART® setting. Note: Only available if expert mode in C6.4.5 is enabled!
C2._.15 Information*	Serial number of the I/O board, software version number and production date of the circuit board. Note: Only available if expert mode in C6.4.5 is enabled!
C2._.0 Freq. Output X	X represents one of the connection terminals A, B or D. _ represents: 1 = Terminals A, 2 = Terminals B, 4 = Terminals D
C2._.1 Measurement	Measurement value for frequency output. Select: Flow Velocity / Volume Flow / Mass Flow / Temperature / Density / Sensor Average / Sensor Deviation / Drive Level / Tube Frequency / Strain 1 / Strain 2 / 2 Phase Signal Depending on the settings for the concentration measurement, the following measurements are possible: Concentration 1 / Concentration 2 / Conc. mass flow 1 / Conc. mass flow 2 / Conc. volume flow 1 / Conc. volume flow 2
C2._.2 Range	0...100% of the measurement value set in C2._.1. x.xx...xx.xx _ _ _ (format and unit depend on the measurement value)
C2._.3 Low Flow Cutoff	Sets the measurement to "0" for low values. x.xxx ± x.xxx%; range: 0.0...20% (1st value = switching point / 2nd value = hysteresis); condition: 2nd value ≤ 1st value
C2._.4 Damping	Range: 0.0...100 s

Function	Description and selection
C2._5 Polarity*	Sets polarity; the flow direction in C1.1.4 must be considered! Select: Both Polarities (plus and minus values are displayed) / Positive Polarity (display for negative values = 0) / Negative Polarity (display for positive values = 0) / Absolute Value (displayed value is positive for both negative and positive measurement values) Note: Only available if expert mode in C6.4.5 is enabled!
C2._6 Pulse Shape	Specify the pulse shape. Select: Symmetric (about 50% on and 50% off) / Automatic (constant pulse with about 50% on and 50% off at 100% pulse rate) / Fixed (fixed pulse rate, setting refer to "C2._9 Max. Pulse Rate")
C2._7 Pulse Width	Only available if set to "Fixed" in C2._6. Range: 0.05...2000 ms Note: max. setting value T_p [ms] \leq 500 / max. pulse rate [1/s], gives the pulse width = time where the output is activated
C2._8 100% Pulse Rate	Frequency for 100% of the measuring range. Range: 1...10000 Hz Limitation 100% pulse rate \leq 100/s: $I_{max} \leq$ 100 mA Limitation 100% pulse rate $>$ 100/s: $I_{max} \leq$ 20 mA
C2._9 Invert Signal	Select: Off (activated output: switch closed) / On (activated output: switch open)
C2._10 Phase Shift w.r.t. B	Only available when configuring the terminal A or D and only if output B is a pulse or frequency output. If setting in C2._5 is "Both Polarities", the phase shift is prefixed by a symbol, e.g. -90° and $+90^\circ$. Select: Off (no phase shift) / 0° Phase Shift (between outputs A or D and B, inversion possible) / 90° Phase Shift (between outputs A or D and B, inversion possible) / 180° Phase Shift (between outputs A or D and B, inversion possible)
C2._11 Information*	Serial number of the I/O board, software version number and production date of the circuit board. Note: Only available if expert mode in C6.4.5 is enabled!
C2._0 Pulse Output X	X represents one of the connection terminals A, B or D. _ represents: 1 = Terminals A, 2 = Terminals B, 4 = Terminals D
C2._1 Measurement	Measurements for activating the output. Select: Mass Flow / Volume Flow
C2._2 Pulse Value Unit	Selection of the unit from a list, depending on the selection of "measurement" in C2._1.
C2._3 Value Per Pulse	Sets value for volume or mass per pulse. xxx.xxx, measured value in unit depending on setting in C2._2. At max. pulse rate refer to "C2._9 Max. Pulse Rate".
C2._4 Low Flow Cutoff*	Sets the measurement to "0" for low values. $x.xxx \pm x.xxx\%$; range: 0.0...20% (1st value = switching point / 2nd value = hysteresis), condition: 2nd value \leq 1st value Note: Only available if expert mode in C6.4.5 is enabled!
C2._5 Damping*	Setting for the pulse output. Range: 0.0...100 s Note: Only available if expert mode in C6.4.5 is enabled!
C2._6 Polarity*	Sets polarity; the flow direction in C1.1.4 must be considered! Select: Both Polarities (plus and minus values are displayed) / Positive Polarity (display for negative values = 0) / Negative Polarity (display for positive values = 0) / Absolute Value (displayed value is positive for both negative and positive measurement values) Note: Only available if expert mode in C6.4.5 is enabled!

Function	Description and selection
C2._7 Pulse Shape	Specify the pulse shape. Select: Symmetric (about 50% on and 50% off) / Automatic (constant pulse with about 50% on and 50% off at 100% pulse rate) / Fixed (fixed pulse rate, setting refer to "C2._9 Max. Pulse Rate")
C2._8 Pulse Width	Only available if set to "Fixed" in C2._7. Range: 0.05...2000 ms Note: max. setting value T_p [ms] \leq 500 / max. pulse rate [1/s], gives the pulse width = time where the output is activated
C2._9 Max. Pulse Rate	Pulse rate for 100% of the measuring range Range: 0.01...10000 Hz Limitation 100% pulse rate \leq 100/s: $I_{max} \leq$ 100 mA Limitation 100% pulse rate $>$ 100/s: $I_{max} \leq$ 20 mA
C2._10 Invert Signal	Select: Off (activated output: switch closed) / On (activated output: switch open)
C2._11 Phase Shift w.r.t. B	Only available when configuring the terminal A or D and only if output B is a pulse or frequency output. If setting in C2._6 is "Both Polarities", the phase shift is prefixed by a symbol, e.g. -90° and $+90^\circ$. Select: Off (no phase shift) / 0° Phase Shift (between outputs A or D and B, inversion possible) / 90° Phase Shift (between outputs A or D and B, inversion possible) / 180° Phase Shift (between outputs A or D and B, inversion possible)
C2._11 Information*	Serial no. of the I/O board, software version no. and production date of the circuit board. Note: Only available if expert mode in C6.4.5 is enabled!
C2._0 Status Output X	X (Y) represents one of the connection terminals A, B or D. _ represents: 1 = Terminals A, 2 = Terminals B, 4 = Terminals D
C2._1 Mode	The output shows the following measuring conditions: Failure (output set, signals status of the category "Failure"; for details refer to <i>Diagnostic information and status messages</i> on page 106) / Out Of Specification (output set, signals status of category "Failure" or "Maintenance Required" or "Out Of Specification"; for details refer to <i>Diagnostic information and status messages</i> on page 106) / Maintenance Required (output set, signals status of category "Failure" or "Maintenance Required"; for details refer to <i>Diagnostic information and status messages</i> on page 106) / Flow Polarity (polarity of the current flow) / Flow Over Range (over range of the flow) / Totaliser 1 Preset (activates when totaliser X preset value is reached) / Totaliser 2 Preset (activates when totaliser X preset value is reached) / Output A (activated by the status of output Y, additional output data see below) / Output B (activated by the status of output Y, additional output data see below) / Output C (activated by the status of output Y, additional output data see below) / Output D (activated by the status of output Y, additional output data see below) / Off (switched off)
C2._2 Output Y	Only available if output A...D is set under "Mode" (see above) and this output is switched off.
C2._3 Invert Signal	Select: Off (activated output: switch closed) / On (activated output: switch open)
C2._4 Information*	Serial no. of the I/O board, software version no. and production date of the circuit board. Note: Only available if expert mode in C6.4.5 is enabled!

Function	Description and selection
C2._0 Limit Switch X	X represents one of the connection terminals A, B or D. _ represents: 1 = Terminals A, 2 = Terminals B, 4 = Terminals D
C2._1 Measurement	Select: Flow Velocity / Volume Flow / Mass Flow / Temperature / Density / Sensor Average / Sensor Deviation / Drive Level / Tube Frequency / Strain 1 / Strain 2 / 2 Phase Signal
C2._2 Threshold	Switching level, set threshold with hysteresis. xxx.x ±x.xxx (format and unit depend on the measurement, see above) (1st value = threshold / 2nd value = hysteresis), condition: 2nd value ≤ 1st value
C2._3 Damping	Setting for the limit switch. Range: 0.0...100 s
C2._4 Polarity*	Sets polarity; the flow direction in C1.1.4 must be considered! Select: Both Polarities (plus and minus values are displayed) / Positive Polarity (display for negative values = 0) / Negative Polarity (display for positive values = 0) / Absolute Value (displayed value is positive for both negative and positive measurement values) Note: Only available if expert mode in C6.4.5 is enabled!
C2._4 Invert Signal	Select: Off (activated output: switch closed) / On (activated output: switch open)
C2._5 Information*	Serial no. of the I/O board, software version no. and production date of the circuit board. Note: Only available if expert mode in C6.4.5 is enabled!
C2._0 Control Input X	X represents one of the connection terminals A or B. _ represents: 1 = Terminals A, 2 = Terminals B
C2._1 Mode	Select: Off (control input switched off) / Hold All Outputs (hold actual values, not display and totalisers) / Hold Output Y (hold actual values) / All Outputs To Zero (actual values = 0%, not display and totalisers) / Output Y To Zero (actual value = 0%) / All Totalisers (reset all totalisers to "0") / Reset Totaliser "Z" (set totaliser 1, 2 or 3 to "0") / Stop All Totalisers (stops all totalisers) / Stop Totaliser "Z" (stops totaliser 1, 2 or 3) / Zero Outp.+Stop Tot. (all outputs 0%, stop all totalisers, not the display) / External Range Y (control input for external range of current output Y) - also make this setting on current output Y (no check if current output Y is available) / Error Reset (all resettable errors are deleted) / Calibrate Zero
C2._2 Invert Signal	Select: Off (activated output: switch closed) / On (activated output: switch open)
C2._3 Information	Serial number of the I/O board, software version number and production date of the circuit board.

Function	Description and selection
C3.0.0 Totalisers	
C3._0 Totaliser _	Set function of totaliser _. _ can be 1...3
C3._1 Totaliser Function	Select: Absolute Total (counts positive + negative values) / Incremental Total (counts only the positive values) / Decremental Total (counts only the negative values) / Off (Totaliser is switched off)
C3._2 Measurement	Selection of the measurement for the totaliser. Select: Volume Flow / Mass Flow Depending on the settings for the concentration measurement, the following measurements are possible: Conc. mass flow 1 / Conc. mass flow 2 / Conc. volume flow 1 / Conc. volume flow 2
C3._3 Low Flow Cutoff*	Sets the measurement to "0" for low values. x.xxx ± x.xxx%; range: 0.0...20% (1st value = switching point / 2nd value = hysteresis), condition: 2nd value ≤ 1st value Note: Only available if expert mode in C6.4.5 is enabled!
C2._4 Damping*	Range: 0.0...100 s Note: Only available if expert mode in C6.4.5 is enabled!
C3._5 Preset Value	If this value is reached, positive or negative, a signal is generated that can be used for a status output at which "Totaliser X Preset" has to be set. Preset Value (max. 8 digits) x.xxxxx in selected unit, refer to C6.5.10 + 13
C3._6 Reset Totaliser	Reset Totaliser _? Select: No / Yes
C3._7 Set Totaliser	Set Totaliser _ to the desired value. Select: Cancel (exit function) / Set Value (opens the editor to make the entry) Query: Set Totaliser? Select: No (exit function without setting the value) / Yes (sets the totaliser and exits the function)
C3._8 Stop Totaliser	Totaliser _ is stopped and holds the actual value. Select: No (exit the function without stopping the totaliser) / Yes (stop the totaliser and exit the function)
C3._9 Start Totaliser	Start Totaliser _ after that totaliser is stopped. Select: No (exits the function without starting the totaliser) / Yes (starts the totaliser and exits the function)
C3._10 Information	Serial number of the I/O board, software version number and production date of the circuit board.

Function	Description and selection
C4.0.0 HART	<p>Selection or display of the 4 dynamic variables (DV) for HART®.</p> <p>The HART® current output (terminal A basic I/Os or terminal C modular I/Os) always has a fixed link to the primary variables (PV). Fixed links of the other DVs (1-3) are only possible if additional analogue outputs (current and frequency output) are available. If not, the measured value can be freely selected from the values in the list in Fct. A3.2.0 "Measurement".</p>
C4.1.0 HART	<p>Switch HART® communication on/off.</p> <p>Select: Enabled (HART® activated) possible current range for current output 4...20 mA / Disabled (HART® not activated) possible current range for current output 0...20 mA</p>
C4.2.0 Loop Current Mode	<p>Configure loop current mode.</p> <p>Select: Disabled = Multi-Drop mode / Enabled = Current Signal mode</p>
C4.3.0 Identification	
C4.3.1 Address	<p>Set address for HART® operation.</p> <p>Select: 00 (Point-to-Point operation; current output has normal function; current = 4...20 mA) / 01...15 (Multi-Drop mode; current output has a constant setting of 4 mA)</p>
C4.3.2 Tag	<p>Measuring point identifier (Tag no.) (also for HART® operation) will be displayed in the LCD header (max. 8 digits).</p>
C4.3.3 Long Tag	<p>Set the HART® Long Tag.</p>
C4.3.4 Manufacturer ID	<p>Display the Manufacturer ID.</p>
C4.3.5 Device Type	<p>Display the device type.</p>
C4.3.6 Electronics Serial No.	<p>Display the serial no. of the electronic assembly.</p>
C4.3.7 Description	<p>Set required text.</p>
C4.3.8 Message	<p>Set required text.</p>
C4.3.9 HART Version	<p>Display HART® version.</p>
C4.3.9 HART Device Revision	<p>Display HART® device revision.</p>
C4.4.0 HART Dyn. Variables	
C4.4.1 PV	<p>Current output (primary variable)</p>
C4.4.2 SV	<p>(secondary variable)</p> <p>Select: Flow Velocity / Volume Flow / Mass Flow / Temperature / Density / Sensor Average / Sensor Deviation / Drive Level / Tube Frequency / Strain 1 / Strain 2 / 2 Phase Signal / Totaliser 1 Mass / Totaliser 1 Volume / Totaliser 2 Mass / Totaliser 2 Volume</p>
C4.4.3 TV	<p>(tertiary variable)</p> <p>Select: Flow Velocity / Volume Flow / Mass Flow / Temperature / Density / Sensor Average / Sensor Deviation / Drive Level / Tube Frequency / Strain 1 / Strain 2 / 2 Phase Signal / Totaliser 1 Mass / Totaliser 1 Volume / Totaliser 2 Mass / Totaliser 2 Volume</p>
C4.4.4 4V	<p>(4th variable)</p> <p>Select: Flow Velocity / Volume Flow / Mass Flow / Temperature / Density / Sensor Average / Sensor Deviation / Drive Level / Tube Frequency / Strain 1 / Strain 2 / 2 Phase Signal / Totaliser 1 Mass / Totaliser 1 Volume / Totaliser 2 Mass / Totaliser 2 Volume</p>

Function	Description and selection
C5.0.0 Display	
C5.1.0 Language	Select language. Available languages: English, German, French, Danish, Spanish, Italian, Dutch, Polish, Portuguese, Swedish, Turkish
C5.2.0 Contrast	Adjust display contrast for extreme temperatures. Setting: -99...+99 This change takes place immediately, not when setting mode is exited!
C5.3.0 Optical Keys	Activate or deactivate the optical keys. Select: Enabled / Disabled
C5.4.0 Backlight	Select the display backlight. Select: Off (no backlight) / White (white backlight) / Red - Failure (red backlight in case of failure status, white backlight otherwise) / NE107 Color (the backlight colour represents the current NE107 status)
C5.5.0 Default Display	Specification of the default display page that is returned to after a short delay period. Select: None (the current page is always active) / 1st Meas. Page (show this page) / 2nd Meas. Page (show this page) / Status Page (show only status messages) / Graphic Page (trend display of the 1st measurement)
C5._0 1st Meas. Page & 2nd Meas. Page	_ = 6 for 1st Meas. Page; _ = 7 for 2nd Meas. Page
C5._1 Function	Specify number of measured value lines (font size). Select: One Line / Two Lines / Three Lines
C5._2 1st Line Variable	Specify measurement for 1st line. Select: Flow Velocity / Volume Flow / Mass Flow / Temperature / Density / Sensor Average / Sensor Deviation / Drive Level / Tube Frequency / Strain 1 / Strain 2 / 2 Phase Signal Depending on the settings for the concentration measurement, the following measurements are possible: Concentration 1 / Concentration 2 / Conc. mass flow 1 / Conc. mass flow 2 / Conc. volume flow 1 / Conc. volume flow 2
C5._3 Range	0...100% of the "Measurement" set in C5._2. x.xx...xx.xx _ _ _ (format and unit depend on the "Measurement")
C5._4 Limitation	Limitation before applying the time constant. \pm xxx... \pm xxx%; Range: -150...+150%
C5._5 Low Flow Cutoff	Sets the measurement to "0" for low values. x.xxx \pm x.xxx%; Range: 0.0...20% (1st value = switching point / 2nd value = hysteresis), condition: 2nd value \leq 1st value

Function	Description and selection
C5._.6 Damping	Range: 0.0...100 s
C5._.7 1st Line Format	Specify decimal places. Select: Automatic (adaptation is carried out automatically) / X (= none) ...X.XXXXXXXXXX°(max. 8 decimal places) depends on size of font
C5._.8 2nd Line Variable	Specify "2nd Line Variable" (only available if this 2nd line is activated). Select: Bargraph (for the "Measurement" selected in the 1st line) / Flow Velocity / Volume Flow / Mass Flow / Temperature / Density / Sensor Average / Sensor Deviation / Drive Level / Tube Frequency / Strain 1 / Strain 2 / 2 Phase Signal / Totaliser 1 Mass / Totaliser 1 Volume / Totaliser 2 Mass / Totaliser 2 Volume / Operating Hours Depending on the settings for the concentration measurement, the following measurements are possible: Concentration 1 / Concentration 2 / Conc. mass flow 1 / Conc. mass flow 2 / Conc. volume flow 1 / Conc. volume flow 2
C5._.9 2nd Line Format	Specify decimal places. Select: Automatic (adaptation is carried out automatically) / X (= none) ...X.XXXXXXXXXX°(max. 8 decimal places) depends on size of font
C5._.10 3rd Line Variable	Specify "3rd Line Variable" (only available if this 3rd line is activated). Select: Flow Velocity / Volume Flow / Mass Flow / Temperature / Density / Sensor Average / Sensor Deviation / Drive Level / Tube Frequency / Strain 1 / Strain 2 / 2 Phase Signal / Totaliser 1 Mass / Totaliser 1 Volume / Totaliser 2 Mass / Totaliser 2 Volume / Operating Hours Depending on the settings for the concentration measurement, the following measurements are possible: Concentration 1 / Concentration 2 / Conc. mass flow 1 / Conc. mass flow 2 / Conc. volume flow 1 / Conc. volume flow 2
C5._.11 3rd Line Format	Specify decimal places. Select: Automatic (adaptation is carried out automatically) / X (= none) ...X.XXXXXXXXXX°(max. 8 decimal places) depends on size of font
C5.8.0 Graphic Page	
C5.8.1 Select Range	Graphic page always shows trend curve of the measurement of the 1st page / 1st line; refer to C5.6.2. Select: Manual (set range in C5.8.2) / Automatic (automatic depiction based on the measured values) Reset only after parameter change or after switching off and on.
C5.8.2 Range	Set the scaling for the Y axis. Only available if "Manual" is set in C5.8.1. ±xxx ±xxx%; range: -100...+100% (1st value = center value / 2nd value = offset); condition: 1st value ≤ 2nd value
C5.8.3 Time Scale	Set the time scaling for the X axis, trend curve. xxx min; range: 0...100 min
C6.0.0 Device	
C6.1.0 Tag	Measuring point identifier (Tag no.) (also for HART® operation) will be displayed in the LCD header (max. 8 digits).
C6.2.0 Reset Errors	Reset Errors? Select: No / Yes

Function	Description and selection
C6.3.0 Config. Management	
C6.3.1 Save Settings	Save current settings. Select: Cancel (exit function without saving) / Backup 1 (save in storage location 1) / Backup 2 (save in storage location 2) Query: Continue To Copy? (cannot be undone) Select: No (exit function without saving) / Yes (copy current settings to storage backup 1 or backup 2)
C6.3.2 Load Settings	Load saved settings. Select: Cancel (exit function without loading) / Factory Settings (restore factory settings) / Backup 1 (load data from storage location 1) / Backup 2 (load data from storage location 2) Query: Continue To Copy? (cannot be undone) Select: No (exit the function without saving) / Yes (load data from the selected storage location)
C6.3.3 Factory Reset	Reset to factory settings. Query: Reset? Select: Factory Settings (reset to factory settings) / Cancel (exit function without resetting to factory settings)
C6.3.4 Set Operator Password	Sets the password required to enable "access authentication". 0000 (= access authentication disabled) xxxx (password required); range 4 digits: 0001...9999
C6.3.5 Password Reset	In case of a lost password, request a reset password from manufacturer. xxxx (password required); range 4 digits: 0001...9999
C6.3.6 Write Lock Selection	Configure application specific lock (for details refer to <i>Locking of configuration</i> on page 103).
C6.4.0 Special Functions	
C6.4.1 Set Date and Time	Set real-time clock.
C6.4.2 Quick Access	Set "Quick Access" function. Select: Off (deactivated) / Reset all Totalisers / Reset Totaliser 1 / Reset Totaliser 2
C6.4.3 GDC IR Interface	After this function has been activated an optical GDC adapter can be connected to the LC display. After 60 seconds pass without a connection being established or after the adapter is removed, the function is exited and the optical keys are active again. Select: Cancel (exit function without connection) / Activate (the IR interface adapter and interrupt the optical keys)
C6.4.4 Cold Start	Perform cold start of measurement device? Select: No / Yes
C6.4.5 Expert Mode	Enable expert mode? (not available in SIL mode) Select: No / Yes
C6.5.0 Units	
C6.5.1 Volume Flow	L/s; L/min; L/h; m ³ /s; m ³ /min; m ³ /h; cf/s; cf/min; cf/h; gal/s; gal/min; gal/h; IG/s; IG/min; IG/h; barrel/h; barrel/day; Free Unit (set factor and text in the next two functions, sequence see below)
C6.5.2 Text Free Unit	For text to be specified refer to <i>Set free units</i> on page 86:
C6.5.3 [m ³ /s]*Factor	Specification of the conversion factor, based on m ³ /s: xxx.xxx refer to <i>Set free units</i> on page 86
C6.5.4 Mass Flow	g/s; g/min; g/h; kg/s; kg/min; kg/h; t/min; t/h; lb/s; lb/min; lb/h; ST/min; ST/h; LT/h; Free Unit (set factor and text in the next two functions, sequence see below)
C6.5.5 Text Free Unit	For text to be specified refer to <i>Set free units</i> on page 86:
C6.5.6 [kg/s]*Factor	Specification of the conversion factor, based on kg/s: xxx.xxx refer to <i>Set free units</i> on page 86

Function	Description and selection
C6.5.7 Flow Velocity	m/s; ft/s
C6.5.9 Temperature	°C; °F; K
C6.5.10 Volume	ml; L; hl; m ³ ; in ³ ; cf; yd ³ ; gal; IG; barrel; Free Unit (set factor and text in the next two functions, sequence see below)
C6.5.11 Text Free Unit	For text to be specified refer to <i>Set free units</i> on page 86:
C6.5.12 [m ³]*Factor	Specification of the conversion factor, based on m ³ : xxx.xxx refer to <i>Set free units</i> on page 86
C6.5.13 Mass	mg; g; kg; t; oz; lb; ST; LT; Free Unit (set factor and text in the next two functions, sequence see below)
C6.5.14 Text Free Unit	For text to be specified refer to <i>Set free units</i> on page 86:
C6.5.15 [kg]*Factor	Specification of the conversion factor, based on kg: xxx.xxx refer to <i>Set free units</i> on page 86
C6.5.16 Density	kg/m ³ ; kg/L; lb/cf; lb/gal; SG; Free Unit (set factor and text in the next two functions, sequence see below)
C6.5.17 Text Free Unit	For text to be specified refer to <i>Set free units</i> on page 86:
C6.5.18 [kg/m ³]*Factor	Specification of the conversion factor, based on kg/m ³ : xxx.xxx refer to <i>Set free units</i> on page 86
C6.6.0 Status Groups	
C6.6.1 Proc: Signal Low*	Selection of status signal (Out of Specification, Failure, Information, Maintenance Required and Function Check) for the group "Proc: Signal Low". Note: Only available if expert mode in C6.4.5 is enabled!
C6.6.2 Proc: Signal Search*	Selection of status signal (Out of Specification, Failure, Information, Maintenance Required and Function Check) for the group "Proc: Signal Search". Note: Only available if expert mode in C6.4.5 is enabled!
C6.6.3 Proc: 2 Phase Flow	Selection of status signal (Out of Specification, Failure, Information, Maintenance Required and Function Check) for the group "Proc: 2 Phase Flow".
C6.6.4 Proc: System Control*	Selection of status signal (Out of Specification, Failure, Information, Maintenance Required and Function Check) for the group "Proc: System Control". Note: Only available if expert mode in C6.4.5 is enabled!
C6.6.5 Config: Totaliser	Selection of status signal (Out of Specification, Failure, Information, Maintenance Required and Function Check) for the group "Config: Totaliser".
C6.6.6 Electr: Power Failure	Selection of status signal (Out of Specification, Failure, Information, Maintenance Required and Function Check) for the group "Electr: Power Failure".
C6.6.7 Electr: IO connection	Selection of status signal (Out of Specification, Failure, Information, Maintenance Required and Function Check) for the group "Electr: IO connection".

Function	Description and selection
C7.0.0 SIL	Note: Only available if expert mode in C6.4.5 is disabled!
C7.1.0 Configuration	
C7.1.1 Tag	Measuring point identifier (Tag no.) (also for HART [®] operation) will be displayed in the LCD header (max. 8 digits).
C7.1.2 Measurement	Select: Flow Velocity / Volume Flow / Mass Flow / Temperature / Density / Sensor Average / Sensor Deviation / Drive Level / Tube Frequency / Strain 1 / Strain 2 / 2 Phase Signal
C7.1.3 Range	Range setting for current output. Selection depends on the measurement value.
C7.1.4 Alarm Code	Specify the failure current output. Select: Low (3.6 mA) / High (21.5 mA)
C7.1.5 Low Flow Cutoff	Sets the measurement to "0" for low values. x.xxx ± x.xxx%; Range: 0.0...20% (1st value = switching point / 2nd value = hysteresis)
C7.1.6 Damping	Setting for the main current output. Range: 0.0...100 s
C7.1.7 Terminals C Type	Select: Passive / Active
C7.1.8 Flow Direction	Define polarity of flow direction. Select: Forwards (acc. to the arrow on the flow sensor) / Backwards (in the opposite direction of the arrow)
C7.1.9 Calibrate Zero	Perform zero calibration. Query: Calibrate zero? Select: Automatic / Factory Calibration / Manual (display last value; set new value; range: -10...+10%) / Cancel (return without calibration)
C7.1.10 2 Phase Threshold	Sets the process-dependent threshold of the 2 phase signal error message. Range: 0.0...1000.0
C7.1.11 Proc: 2 Phase Flow	Change NE107 status signal for status group "Proc: 2 Phase Flow". Select: Out of Specification / Failure / Information / Maintenance Required / Function Check
C7.1.12 Alarm Condition	Sets the condition that triggers an alarm. Select: Safety Rel. Failures / Failure / Out of Specification
C7.2.0 Safety Mode	Select: Non-SIL / SIL Mode (not available in expert mode)
C7.3.0 SIL Verification	Verification of safety relevant parameters and lock of the device. Note: Only available if "Safety Mode" is changed!
C7.4.0 Unlock Device	Unlock device.
C7.5.0 Unlock Password	Set the password required to unlock the device. xxxx (password required); range 4 digits: 0001...9999

6.3.4 Set free units

Free units	Sequences to set texts and factors
Texts	
Volume flow, mass flow and density	3 digits before and after the slash xxx/xxx (max. 6 characters plus a "/")
Permissible characters	A...Z; a...z; 0...9; / - + , . * ; @ \$ % ~ () [] _
Conversion factors	
Desired unit	= [unit see above] * conversion factor
Conversion factor	Max. 9 digits
Shift decimal point	↑ to the left and ↓ to the right

6.4 Calibration functions

6.4.1 Zero calibration (C1.1.1 Calibrate Zero)

Following installation, perform zero calibration prior to commissioning the device. Finalise the installation before performing zero calibration. Changes (pipe system or calibration factor) made after the zero calibration may affect the accuracy, making it necessary to perform zero calibration again.

Observe the following for reliable zero calibration:

- The flow sensor should be completely filled with the product at the expected process pressure and temperature.
- The product may contain no air or gas, especially when it comes to horizontal installations. Prior to zero calibration, it is recommended that the product be flushed at a high flow rate (>50%), for 2 minutes.
- After flushing, re-establish zero flow by closing off the corresponding valves.

Set zero calibration automatically or manually using the operating controls. The signal converter cover must be installed on the display for automatic calibration.

Key	Screen	Description
>	A0.0.0 Quick Setup	Press and hold for 2.5 s, then release the key.
2 x ↓	C0.0.0 Setup	
3 x >	C1.1.1 Calibrate Zero	
>	Calibrate Zero? Automatic	
←	Please Wait	A progress bar indicates the progress of zero calibration.
	Calibrate Zero Passed	
←	Calibrate Zero +XX.XXX%	Display of measured zero calibration in %.
5 x ←	Save Configuration? Yes	
←	Display page	

Table 6-5: Procedure for "Automatic calibration"

Key	Screen	Description and setting
>	A0.0.0 Quick Setup	Press and hold for 2.5 s, then release the key.
2 x ↓	C0.0.0 Setup	
3 x >	C1.1.1 Calibrate Zero	
>	Calibrate Zero? Automatic	
2 x ↓	Calibrate Zero? Manual	
	Calibrate Zero +XX.XXX%	Display currently stored zero calibration in %. Warning: value can be changed! Possible manual entry of zero calibration.
		Storing the displayed zero calibration.
5 x ←	Save Configuration? Yes	
←	Display page	

Table 6-6: Procedure for "Manual calibration"

Zero calibration log (B1.3.0 Zero Calibration Log)

Zero calibrations are recorded in the zero calibration log. Log information includes zero offset, temperature, date and time. Navigate using the ↑ and ↓ keys. Exit the menu using the ← key.

Under certain conditions, zero calibration is not possible and will be cancelled:

- The product is still flowing. The shut-off valves are not closed tightly enough.
- There are still gas bubbles in the flow sensor.
Remedy: Flush flow sensor and repeat calibration

With some media, it may be difficult to perform zero calibration. In such cases, there are various methods to still achieve good zero calibration:

Medium	Possible solutions
Media that tend to evaporate or outgas	Increase pressure.
Two-phase media (slurries), that contain solids that may fall out.	Only fill the flow sensor with the carrier medium.
Two-phase media in which the solids or gas-forming components cannot be separated.	Fill flow sensor with another liquid, e.g. water.

Table 6-7: Zero calibration for difficult media

6.4.2 Density calibration (C1.2.1 Calibrate Density)

Mass flowmeters are calibrated for density in the factory. Density calibration is based on 2 calibration points. In the factory, air and water are used under reference conditions. The result of this calibration is saved in the converter electronics and stored in the factory settings. Regardless, various applications require maximum accuracy which can only be achieved with on-site calibration.

Option	Explanation
1 Point Calibration	One of the 2 saved calibration points is replaced by customer calibration. The signal converter decides which of the 2 calibration points is modified.
2nd Calibration Point	Calibration of the 2nd point.
Factory Calibration	The signal converter reactivates the factory settings for the density calibration.

Table 6-8: Available density calibration options

Key	Screen	Description and setting
>	A0.0.0 Quick Setup	Press and hold for 2.5 s, then release the key.
2 x ↓	C0.0.0 Setup	
↓	C1.2.0 Density	
2 x >	C1.2.1 Calibrate Density 1 Point Calibration	
←	Density Calib. Product XXXXXXX	
Press ↓ until	Density Calib. Product Town Water	
←	Calibrate Density? OK	
←	Please Wait	A progress bar indicates the progress of zero calibration.
	Calibrate Density Passed	
5 x ←	Save Configuration? Yes	
←	Display page	

Table 6-9: Example of 1 point calibration with town water

On-site density calibration:

- Ensure that the device has been properly installed and functions smoothly.
- If air (empty) is used as the medium, the measuring tube must be completely dry and free of liquids and solids. If possible, blow dry air into the measuring tube to empty it.
- If liquids are used, flush for a few minutes at a high flow rate to remove gas bubbles.
- Set the flow rate to a typical value (50% of the nominal flow is ideal).
- If the process temperature is higher than the ambient temperature, wait until the system has stabilised.
- When it comes to 1 point and 2 point calibration, you can choose from the options "Empty", "Pure Water", "Town Water" and "Other". The reference values for the specified products are stored in the signal converter.

Density calibration has failed if "Density Calib. Error" is displayed. The reason for the error may be indicated on the display. Possible reasons for failed density calibration:

- The device is not in "Measurement" mode.
- The calibration points are too close together.
- One or more calibration points did not pass the plausibility test.
- Flow, pressure, temperature or system are not stable?
- Please check your system and try again.
- If this results in another failed calibration, please contact the manufacturer.

1 Point Calibration

- See examples for "Calibration with town water and other".
- Select the function using ↓ and ↑ and then confirm with ↵.
- If "Other" is selected, the product density must be entered.
- 1 point calibration is generally sufficient for most applications, such as adapting the density measurement to a new installation.
- Make sure that prior to calibrating the 2nd point that 1 point calibration was carried out and that the result was saved with the dialog "Save Configuration?".

2 Point Calibration

- In this case, both reference points are recalibrated (with the products of the system).
- With 2 point calibration, ensure that both calibration points entered by the user are accepted.

If the 2nd point cannot be calibrated immediately after the first one, because the 2nd product is not yet available, the device continues to function normally as after the 1 point calibration. In other words, there can be weeks or even months between the calibration of the two measuring points.

6.4.3 Temperature/density tables

Temperature		Density		Temperature		Density	
°C	°F	kg/m ³	lb/ft ³	°C	°F	kg/m ³	lb/ft ³
0	32	999.8396	62.41999	0.5	32.9	999.8712	62.42197
1	33.8	999.8986	62.42367	1.5	34.7	999.9213	62.42509
2	35.6	999.9399	62.42625	2.5	36.5	999.9542	62.42714
3	37.4	999.9642	62.42777	3.5	38.3	999.9701	62.42814
4	39.2	999.972	62.42825	4.5	40.1	999.9699	62.42812
5	41	999.9638	62.42774	5.5	41.9	999.954	62.42713
6	42.8	999.9402	62.42627	6.5	43.7	999.9227	62.42517
7	44.6	999.9016	62.42386	7.5	45.5	999.8766	62.4223
8	46.4	999.8482	62.42053	8.5	47.3	999.8162	62.4185
9	48.2	999.7808	62.41632	9.5	49.1	999.7419	62.41389
10	50	999.6997	62.41125	10.5	50.9	999.6541	62.40840
11	51.8	999.6051	62.40535	11.5	52.7	999.5529	62.40209
12	53.6	999.4975	62.39863	12.5	54.5	999.4389	62.39497
13	55.4	999.3772	62.39112	13.5	56.3	999.3124	62.38708
14	57.2	999.2446	62.38284	14.5	58.1	999.1736	62.37841
15	59	999.0998	62.3738	15.5	59.9	999.0229	62.36901
16	60.8	998.9432	62.36403	16.5	61.7	998.8607	62.35887
17	62.6	998.7752	62.35354	17.5	63.5	998.687	62.34803
18	64.4	998.596	62.34235	18.5	65.3	998.5022	62.3365
19	66.2	998.4058	62.33047	19.5	67.1	998.3066	62.32428
20	68	998.2048	62.31793	20.5	68.9	998.1004	62.31141
21	69.8	997.9934	62.30473	21.5	70.7	997.8838	62.29788
22	71.6	997.7716	62.29088	22.5	72.5	997.6569	62.28372
23	73.4	997.5398	62.27641	23.5	74.3	997.4201	62.26894
24	75.2	997.2981	62.26132	24.5	76.1	997.1736	62.25355
25	77	997.0468	62.24563	25.5	77.9	996.9176	62.23757
26	78.8	996.7861	62.22936	26.5	79.7	996.6521	62.22099
27	80.6	996.5159	62.21249	27.5	81.5	996.3774	62.20384
28	82.4	996.2368	62.19507	28.5	83.3	996.0939	62.18614
29	84.2	995.9487	62.17708	29.5	85.1	995.8013	62.16788
30	86	995.6518	62.15855	30.5	86.9	995.5001	62.14907
31	87.8	995.3462	62.13947	31.5	88.7	995.1903	62.12973
32	89.6	995.0322	62.11986	32.5	90.5	994.8721	62.10987

33	91.4	994.71	62.09975	33.5	92.3	994.5458	62.08950
34	93.2	994.3796	62.07912	34.5	94.1	994.2113	62.06861
35	95	994.0411	62.05799	35.5	95.9	993.8689	62.04724
36	98.6	993.6948	62.03637	36.5	97.7	993.5187	62.02537
37	98.6	993.3406	62.01426	37.5	99.5	993.1606	62.00302
38	100.4	992.9789	61.99168	38.5	101.3	992.7951	61.98020
39	102.2	992.6096	61.96862	39.5	103.1	992.4221	61.95692
40	104	992.2329	61.9451	40.5	104.9	992.0418	61.93317
41	105.8	991.8489	61.92113	41.5	106.7	991.6543	61.90898
42	107.6	991.4578	61.89672	42.5	108.5	991.2597	61.88434
43	109.4	991.0597	61.87186	43.5	110.3	990.8581	61.85927
44	111.2	990.6546	61.84657	44.5	112.1	990.4494	61.83376
45	113	990.2427	61.82085	45.5	113.9	990.0341	61.80783
46	114.8	989.8239	61.79471	46.5	115.7	989.6121	61.78149
47	116.6	989.3986	61.76816	47.5	117.5	989.1835	61.75473
48	118.4	988.9668	61.7412	48.5	119.3	988.7484	61.72756
49	120.2	988.5285	61.71384	49.5	121.1	988.3069	61.70
50	122	988.0839	61.68608	50.5	122.9	987.8592	61.67205
51	123.8	987.6329	61.65793	51.5	124.7	987.4051	61.64371
52	125.6	987.1758	61.62939	52.5	126.5	986.945	61.61498
53	127.4	986.7127	61.60048	53.5	128.3	986.4788	61.58588
54	129.2	986.2435	61.57118	54.5	130.1	986.0066	61.5564
55	131	985.7684	61.54153	55.5	131.9	985.5287	61.52656
56	132.8	985.2876	61.51115	56.5	133.7	985.0450	61.49636
57	134.6	984.8009	61.48112	57.5	135.5	984.5555	61.4658
58	136.4	984.3086	61.45039	58.5	137.3	984.0604	61.43489
59	138.2	983.8108	61.41931	59.5	139.1	983.5597	61.40364
60	140	983.3072	61.38787	60.5	140.9	983.0535	61.37203
61	141.8	982.7984	61.35611	61.5	142.7	982.5419	61.34009
62	143.6	982.2841	61.324	62.5	144.5	982.0250	61.30783
63	145.4	981.7646	61.29157	63.5	146.3	981.5029	61.27523
64	147.2	981.2399	61.25881	64.5	148.1	980.9756	61.24231
65	149	980.7099	61.22573	65.5	149.9	980.4432	61.20907

66	150.8	980.1751	61.19233	66.5	151.7	979.9057	61.17552
67	152.6	979.6351	61.15862	67.5	153.5	979.3632	61.14165
68	154.4	979.0901	61.1246	68.5	155.3	978.8159	61.10748
69	156.2	978.5404	61.09028	69.5	157.1	978.2636	61.07300
70	158	977.9858	61.05566	70.5	158.9	977.7068	61.03823
71	159.8	977.4264	61.02074	71.5	160.7	977.145	61.00316
72	161.6	976.8624	60.98552	72.5	162.5	976.5786	60.96781
73	163.4	976.2937	60.95002	73.5	164.3	976.0076	60.93216
74	165.2	975.7204	60.91423	74.5	166.1	975.4321	60.89623
75	167	975.1428	60.87816	75.5	167.9	974.8522	60.86003
76	168.8	974.5606	60.84182	76.5	169.7	974.2679	60.82355
77	170.6	973.9741	60.80520	77.5	171.5	973.6792	60.7868
78	172.4	973.3832	60.76832	78.5	173.3	973.0862	60.74977
79	174.2	972.7881	60.73116	79.5	175.1	972.489	60.71249
80	176	972.188	60.69375				

6.5 Measurement functions

6.5.1 Flow (C1.1.0 Flow)

Flow direction (C1.1.4 Flow Direction)

This function allows the operator to set the direction of flow in relation to the arrow on the housing. If "Forwards" is selected, the flow direction corresponds to the "+" arrow and with "Backwards" the flow direction corresponds to the "-" arrow on the housing.

Process noise damping (C1.1.5 Process Noise Damping)

The flow and density measurements are filtered in order to reduce process noise. The time constant of this filter can be changed in C1.1.5.

If you require a faster response of the device, e.g. for short batches, you could reduce this time. This parameter is only available if the device is switched to expert mode (C6.4.5).

Low flow cutoff (C1.1.6 Low Flow Cutoff)

The flow sensor provides a low flow cutoff (C1.1.6) which is a percentage value of nominal mass flow rate. The low flow cutoff is enabled by default sets all flow measurement variables to zero when the flow is below the low flow cutoff value entered.

This parameter is only available if the device is switched to expert mode (C6.4.5).

Pressure suppression (C1.1.7 & C1.1.8)

The pressure suppression eliminates any disruption in the measurement in the event of an abrupt flow switch-off e.g. when valves are suddenly closed. In such cases, surges may occur in the pipe and in the measuring device which could lead to over-vibration. The flow then "swings" back and forth before a stable zero flow is established, as shown in the figure below. This effect occurs mainly in high pressure applications.

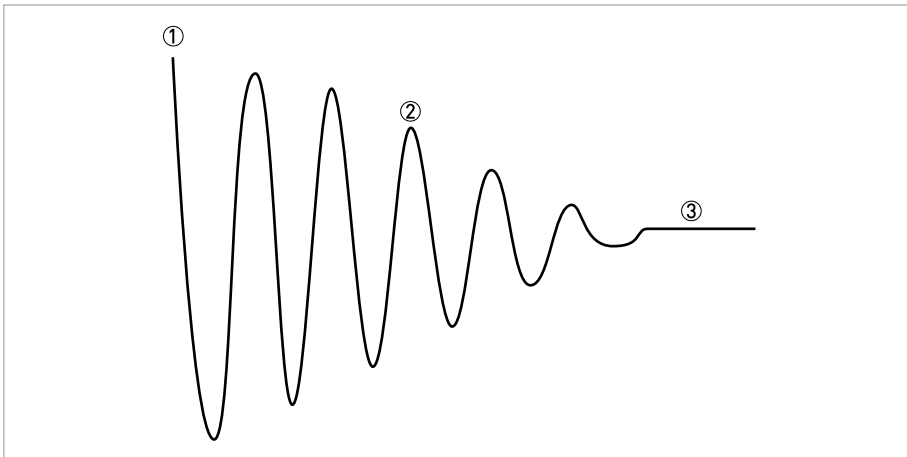


Figure 6-7: Vibration behaviour during pressure suppression

- ① Flow switched off
- ② Sinusoidal vibration ("over-vibration")
- ③ Stable zero flow

The pressure suppression function eliminates this effect by activating a larger low flow cutoff threshold for a programmable period of time. The pressure suppression is activated when the flow falls below the standard low flow cutoff level for the first time (C1.1.6). For a programmable period of time (C1.1.8), the pressure suppression threshold is added to the standard low flow threshold (C1.1.7).

This parameter is only available if the device is switched to expert mode (C6.4.5).

Measurement of flow velocity

The signal converter can provide the flow velocity based on a pipe diameter which the operator can freely program (C1.1.9). This value can either be the inner diameter of the measuring tube (factory setting) or the inner diameter of the process pipe.

6.5.2 Density (C1.2.0 Density)

Density mode (C1.2.2 Density Mode)

There are 4 available operating modes for density that can be set here:

- Process:
The device measures and displays the current operating density of the product.
- Fixed:
The device displays a fixed density value. This value must be entered in menu C1.2.3.
- Referred:
The device calculates the density based on a set reference temperature.
- Standard:
The device calculates the standard density based on a set reference temperature and the correction factors $k_0...k_2$, so that a standard volume can be output.

The following equation is used for the "Referred" mode:

$$\rho_r = \rho_a + a (t_a - t_r)$$

ρ_r = Density at reference temperature

ρ_a = Current measured operating density at current operating temperature

a = Programmed temperature coefficient/density gradient

t_a = Current measured operating temperature

t_r = Reference temperature

The reference temperature must be entered in menu item C1.2.4. The density gradient is set in C1.2.5.

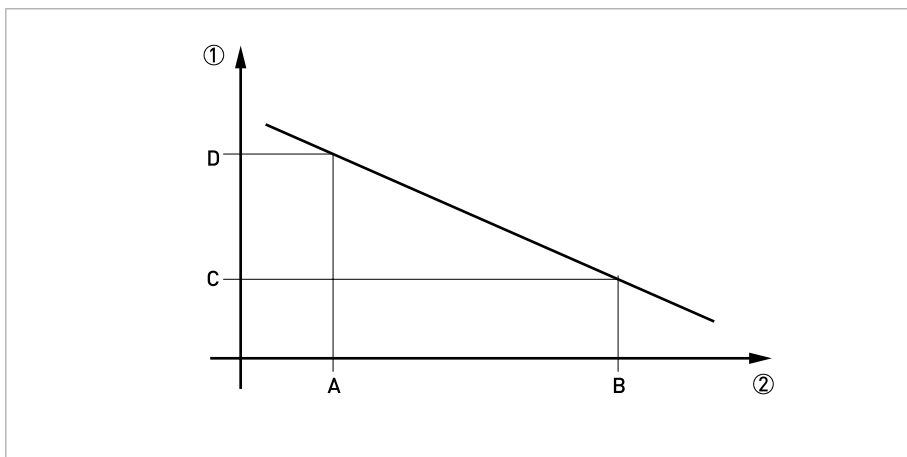


Figure 6-8: Calculating the density gradient

① Density

② Temperature

The following equation is used to calculate the density gradient:

$$a = (\rho_D - \rho_C) / (T_B - T_A)$$

The value for the density gradient is generally positive as an increase in temperature usually reduces the measured density (exception: water anomaly).

Calculating the standard density

The measuring device can display a density which has been corrected in terms of the standard temperature in accordance with API 11.1. Standard 2540.

The corresponding reference temperature is entered in menu C1.2.4. The correction factors k_0 ... k_2 are entered in menu C1.2.7...C1.2.9.

Type of product (acc. to API)	Low limit ρ_{15}	High limit ρ_{15}	k_0	k_1	k_2
	[kg/m ³]				
Crude oil	610.5	1075.0	613.9723	0	0
Gasoline	653.0	770.0	346.4228	0.4388	0
Transition area	770.5	787.5	2680.3206	0	-0.00336312
Jet group	788.0	838.5	594.5418	0	0
Fuel oil	839.0	1075.0	186.9696	0.4862	0
Free fill in	500.0	2000.0	0	0	0

Table 6-10: Example of standard factors

6.5.3 System control (C1.4.0 System Control)

The signal converter provides a system control function which allows to set the flow to 0 in case of a programmable process conditions. The system control function can be enabled in menu C1.4.1. The following menu items configure the condition and limits for activation of system control:

This parameter is only available if the device is switched to expert mode (C6.4.5).

C1.4.2 Condition

Selecting the process measurement which activates the system control. Density and temperature can be selected.

C1.4.3 Max. Temperature/Density & C1.4.3 Min. Temperature/Density

Setting the limit values to activate system control. Current measuring values outside of this range activate this function.

6.5.4 Detection of 2 phase flow

Due to EGM™ (Entrained Gas Management) the device performs a stable measurement function between 0...100% gas ratio. The device provides a signal which indicates two phase flow. This signal can be used to for signalling two phase flow according to NE 107 or for approximating the amount of entrained gas. The signal depends on the amount, distribution and size of the entrained gas and therefore any threshold has to be adapted on the application.

Screen	Description and setting
B2.14.0 2 Phase Signal	Display of actual value for two phase signal.

Table 6-11: Display of two phase signal

Screen	Description and setting
C1.5.2 Diagnosis 1	Set "2 Phase Signal".

Table 6-12: Output of two phase signal via any I/O or measure page

Screen	Description and setting
C1.5.1 2 Phase Threshold	Set a value above 0 in order to activate the two phase signalling via the device and process value status. In case of two phase flow the status message "2 Phase Flow Detected" is generated.
C6.6.3 Proc: 2 Phase Flow	Select the status signal for two phase flow.

Table 6-13: Signalling of 2 phase flow

6.6 I/O configuration

6.6.1 Damp output signals

All digital and analogue outputs provide damping with a digital filter which allows to stabilise the output. The damping can be individually set for each output by a time constant. However, keep in mind that the degree of filtration affects the response time of the device in the event of rapid changes.

The general behaviour of the damping value is:

- Small damping:
 - Fast response times
 - Fluctuating reading
- Large damping:
 - Slow response time
 - Stable reading

The damping corresponds to the elapsed time until 63% of the end value has been reached according to a step function. The time until 90% of the end value is reached in case of a step response is $T_{90} = \tau * 1.8$ (τ = damping).

6.6.2 Suppress small flow rates

All digital and analogue outputs provide a low flow cutoff for flow measurements in order to suppress small flowrates.

If the low flow cutoff has been activated, the respective output is set to zero when the flow is below the low flow cutoff value entered. The value can be entered as a percentage of the upper range value or in the case of a pulse output as a discrete flow value.

Two values must be entered. The first is for the operating point of the flow sensor and the second is for hysteresis.

Condition: 1st value > 2nd value

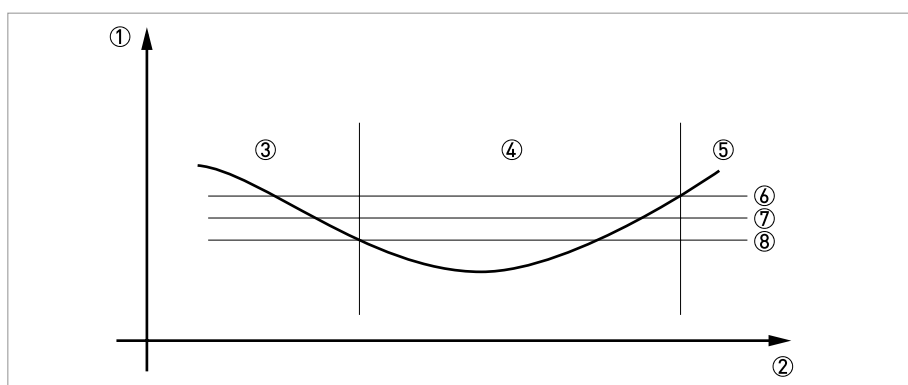


Figure 6-9: Indication of low flow cutoff

- ① Flow
- ② Time
- ③ Currently indicated flow
- ④ Display set to zero
- ⑤ Currently indicated flow
- ⑥ Positive hysteresis
- ⑦ Operating point
- ⑧ Negative hysteresis

6.6.3 Polarity of measurement

All digital and analogue outputs provide a polarity setting which allows:

Polarity	Function
Both	Polarity function does not affect output values.
Positive	Positive values passed to output, negative values set to 0.
Negative	Absolute value of negative values passed to output, positive values set to 0.
Absolute	Absolute value of input values.



INFORMATION!

For reverse flow detection at a current output set polarity to "Both" and select the lower and upper flow range values for your application.

6.6.4 Current output

The current outputs of the signal converter have several operation modes which can be configured by the current span and the alarm signal. The lower and upper range value is mapped to the lower and upper endpoint as depicted in the following figure:

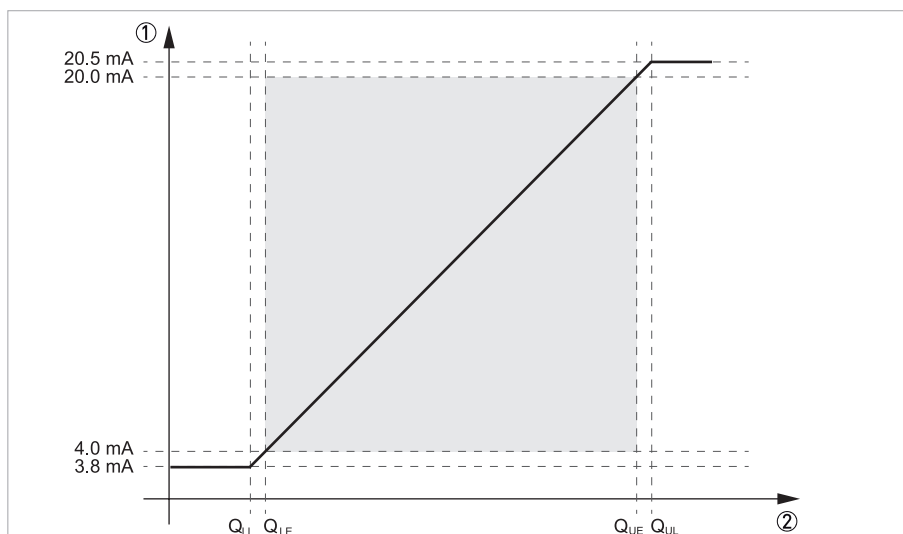


Figure 6-10: Operation modes of the current output

- ① Output current
- ② Measuring value

Current span	Lower limit (Q _{LL})	Lower end point (Q _{LE})	Upper end point (Q _{UE})	Upper limit (Q _{UL})	Low alarm	High alarm
[mA]						
4...20	3.8	4.0	20.0	20.5	3.5	21.5
0...20 ①	0	0	20.0	20.0	0 ②	21.5
Custom	Custom values				Custom values	

Table 6-14: Limit values

① Only available if HART is disabled or not available for respective current output

② Low alarm signalling is not recommended for current span 0...20 mA

Reaching the lower or upper limit is signalled by the status "Out of Specification" but does not set an alarm signal. All current outputs detect an open loop or output current errors due to exceeded load values.

6.6.5 Alarm signalling via current outputs

Current outputs provide an alarm signalling via upper or lower failure current. The alarm signal is set by default in case of device failure, i.e. if the status signal failure is set. If additional status signals should be considered, the error condition can be changed:

Alarm condition	Evaluated status signals
Failure	Failure
Out of Spec	Failure or Out of Spec

Table 6-15: Alarm conditions

6.6.6 Pulse output and batching applications

Pulse outputs of the signal converter are designed for minimum latency and suited for use with pulse counters (mechanical, digital) or provers (e.g. small volume provers). Select the maximum output frequency according to your counter.

Some custody transfer applications require dual phase pulse outputs. For this purpose pulse outputs from two terminals can be paired. Terminal pairs A and B or D and B can be used.



In this case, perform the following settings:

- Configure pulse output terminal A or D
- Set "Output B" to phase shifted mode in menu C2.3.10 by choosing the base pulse output (A or D). All functions for output B are set using output D or output A.
- Phase shift relative to output A: set phase shift (0°, 90° or 180°) in menu C2.2.10
Phase shift relative to output D: set phase shift (0°, 90° or 180°) in menu C2.4.10

6.7 Display configuration

6.7.1 Optical keys (C5.3.0 Optical Keys)

This function can deactivate the optical keys. In this case, the device may only be operated using the push buttons. In the display, the switched off state of the optical keys is represented the following symbol in the upper right corner:

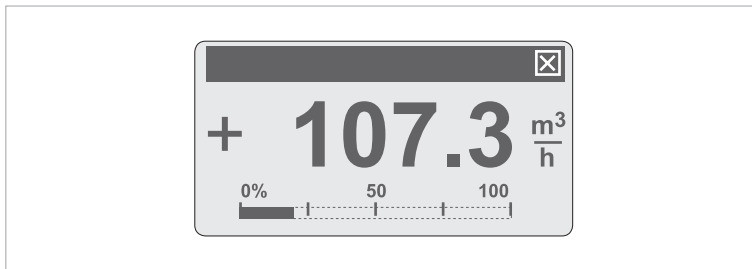


Figure 6-11: Indication of optical keys in switched off state

6.7.2 Backlight (C5.4.0 Backlight)

The signal converter's local display has a colour backlight which can be used to show the NE 107 status. In menu C5.4.0 its behaviour can be configured as described in the following table:

Backlight settings	Description
Off	Backlight always turned off.
White	Backlight colour is always white.
Red - Failure	Backlight colour is set to red in case of a device failure.
NE107 Color	Backlight colour is set according to the NE 107 status of the device.

Table 6-16: Description of backlight settings

6.8 Configuration management (C6.3.0 Config. Management)

6.8.1 Load and save configuration (C6.3.2 & C6.3.1)

The signal converter provides functions to store and restore sets of configurations (Backup 1 and Backup 2). Using the functions in C6.3.2 the present configuration can be stored for later restoration via C6.3.1.

For documentation purposes please note the checksum for the present configuration (B1.2.0 Change Log).

6.8.2 Factory reset (C6.3.3 Factory Reset)

The signal converter configuration can be reset to factory configuration.



INFORMATION!

Be careful with this function because this process cannot be reverted.

6.8.3 Change log (B1.2.0 Change Log)

Any configuration change of the signal converter is logged within a change log (B1.2.0) with date and time and a checksum of the signal converter configuration. The change log covers all device parameters (incl. factory parameters) and provides 128 entries.

6.8.4 Locking of configuration

Access authentication

The signal converter has a multilevel access authentication concept which allows to protect the entire configuration against unauthorised write accesses. The access authentication is disabled by default, however can be enabled by setting an operator password that is not equal to 0000. In case of an enabled access authentication, write accesses via any interface (local display, HART®, OPTICHECK, ...) can only be performed after authentication by entering the respective access level password (refer to next table). Entering this password only unlocks the currently used interface but no other interfaces.

Level	Description	Authentication
0	User / Free	No authentication necessary.
1	Operator	Operator password (C6.3.4 Set Operator Password) or no authentication necessary if operator password not set (0000).
2	Service	Service password.
Jumper	Application Specific Lock	Remove jumper.

Table 6-17: Available access levels

A lock of parameters and functions via access authentication is indicated as depicted in the following figure:

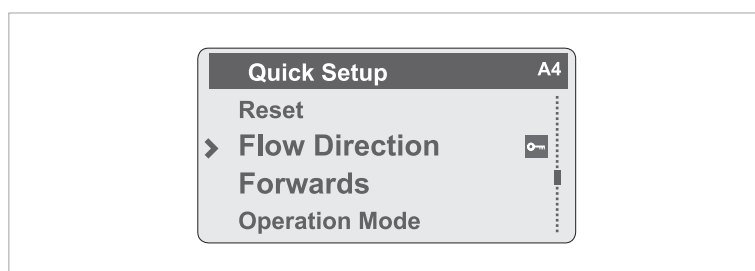


Figure 6-12: Indication of access authentication

Application specific lock (C6.3.6 Write Lock Selection)

Custody transfer (CT) applications require a lock for all parameters and functions which affect the relevant measurement and outputs. For this purpose the signal converter provides an application specific lock which can be enabled by a jumper. The lock mechanism can be configured before applying the jumper in order to lock only CT relevant functions and parameters. The following table shows the locking combinations which can be selected in C6.3.6 and the respective locked functionalities and parameters:

x = locked configuration

Selection in C6.3.6 / Locked entries	Terminal A	Terminal B	Terminal C	Terminal D	Sensor	Totalizer 1	HMI
None	-	-	-	-	-	-	-
Term. C+S	-	-	x	-	x	-	-
Term. D+S	-	-	-	x	x	-	-
Term. BD+S	-	x	-	x	x	-	-
Term. CD+S	-	-	x	x	x	-	-
Term. ABD+S	x	x	-	x	x	-	-
Term. BCD+S	-	x	x	x	x	-	-
Term. ABCD+S	x	x	x	x	x	-	-
HMI+S+Tot.1	-	-	-	-	x	x	x
Term. C+S+HMI+Tot.1	-	-	x	-	x	x	x
Term. D+S+HMI+Tot.1	-	-	-	x	x	x	x
Term. BD+S+HMI+Tot.1	-	x	-	x	x	x	x
Term. CD+S+HMI+Tot.1	-	-	x	x	x	x	x
Term. ABD+S+HMI+Tot.1	x	x	-	x	x	x	x
Term. BCD+S+HMI+Tot.1	-	x	x	x	x	x	x
Term. ABCD+S+HMI+Tot.1	x	x	x	x	x	x	x

Table 6-18: Possible locking combinations

The lock is enabled directly after applying the jumper and is indicated by a lock icon in the upper right corner or at the locked parameter or function.

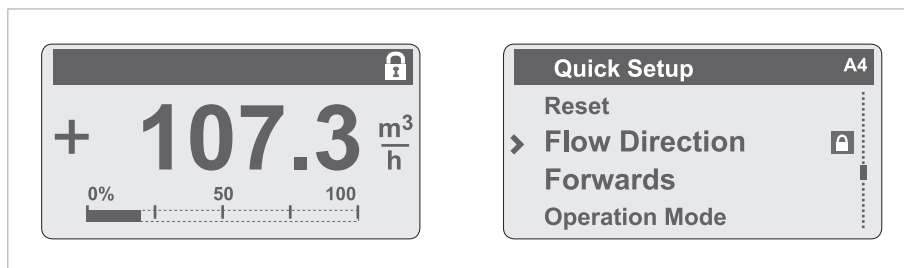


Figure 6-13: Indication of lock icon

Changes to these parameters only can be performed after removal of the lock jumper.

6.9 Special functions

Quick access (C6.4.2 Quick Access)

The local display provides a quick access function which can be used to reset totaliser 1, 2, 3 or all totalisers. Pressing the "←" key for 2.5 seconds carries out the "Quick Access" function.

Date and time (C6.4.1 Set Date and Time)

The signal converter has a real time clock which is used for all of the log functions in the device. This function can be used to set the date and time of the real time clock.

Expert mode (C6.4.5 Expert Mode)

The signal converter local menu is designed to show only functions and parameters which are used by most users. For some applications additional functions (e.g. process noise damping, pressure suppression, ...) are required which are only available if the expert mode (C6.4.5) is enabled. Within this mode the device cannot be set to SIL mode (only SIL capable device). If the expert mode is disabled all expert mode parameters are reset to their default values.

6.10 SIL configuration (only for SIL capable devices)

Refer to "Safety manual" in case of functional safe device variant.

6.11 Testing of device installation (B3.0.0 Simulation)

During installation of the device, the configuration should be tested using simulation functions of the signal converter (B3). The following simulation functions are available:

Function	Description
B3.2.0 Mass Flow	Simulation of process variable mass flow.
B3.3.0 Volume Flow	Simulation of process variable volume flow.
B3.4.0 Density	Simulation of process variable density.
B3.5.0 Temperature	Simulation of process variable temperature.
B3.6.0 Status	Simulation of device status and process value status. This function requires a device status without failures.
B3.7.0 I/O A to B3.10.0 I/O D	Simulation of output signals for I/Os.

Table 6-19: Available simulation functions



INFORMATION!

- Several simulation functions can run in parallel.
- Simulation functions only affect the respective process variable and do not affect derived process variables (e.g. simulation of mass flow does not affect volume flow).



WARNING!

Once started simulation functions continue until they are stopped or the device performs a power cycle. The device status "Function Check" indicates running simulation functions. Use function "A2.2.0 Stop all Simulations" to stop all running simulation functions simultaneously.

6.12 Diagnostic information and status messages

The signal converter continuously carries out various diagnostic functions during operation. The diagnostic function are e.g.:

- Sensor channels and amplifiers checks using reference signals
- Internal voltages against references
- Monitoring of voltages and safety relevant resistances using references
- CPU memory, OP codes check and temporal monitoring
- Internal communication monitoring
- Electronics temperature monitoring
- Current loop monitoring
- Sensor integrity
- Process conditions
- ...

This diagnostic information is displayed in accordance with NAMUR standard NE 107.

To facilitate identification of the problem source, all messages are sorted into the status groups:

- Sensor
- Configuration
- Electronics
- Process

Each status group has one status signal. There are 16 status groups with fixed status signals and 7 groups with variable status signals.



INFORMATION!

As status message always the name of the relevant status group and the status signal is displayed.

The variable status signal can be changed in menu C6.6. Changing the status signal to "Information" switches off the message.

6.12.1 Status groups (C6.6.0 Status Groups)

Each status group has a defined status signal and contains several status messages.

*: Status signal cannot be changed.

F: Failure

C: Function Check

S: Out of Specification

M: Maintenance Required

	Status group	Description
F*	Sensor	"Failure" in sensor.
F*	Electronics	"Failure" in electronics.
F*	Configuration	"Failure" in configuration.
F*	Process	"Failure" in process.
C*	Sensor	"Function Check" in sensor.
C*	Electronics	"Function Check" in electronics.
C*	Configuration	"Function Check" in configuration.
C*	Process	"Function Check" in process.
S*	Sensor	"Out of Specification" in sensor.
S*	Electronics	"Out of Specification" in electronics.
S*	Configuration	"Out of Specification" in configuration.
S*	Process	"Out of Specification" in process.
M*	Sensor	"Maintenance Required" in sensor.
M*	Electronics	"Maintenance Required" in electronics.
M*	Configuration	"Maintenance Required" in configuration.
M*	Process	"Maintenance Required" in process.
F	Proc: Signal Search	Searching signal.
S	Proc: Signal Low	Signal is low.
S	Proc: 2 Phase Flow	Two phase flow detected.
S	Electr: IO Connection	Open circuit or too big load at current output.
S	Config: Totaliser	Overflow of any totaliser.
I	Proc: System Control	System control function active.
I	Electr: Power Failure	Power failure occurred.
I*	Electr: Operation Info.	Operation information.

Table 6-20: Description of status groups

6.12.2 Status log (B1.1.0 Status Log)

The history of status messages is logged by the signal converter with date and time. Menu B1.1.0 shows the log of a status event.

- ↳ Shows the beginning of a status event.
- | Shows the end of a status event.

6.12.3 Reset errors (A2.1.0 Reset Errors)

Some diagnostic functions generate latching status messages which need to be acknowledged by the operator. For this purpose use "Reset Errors" in A2.1.0.

7.1 Replacing the signal converter electronics

**DANGER!**

Work on the signal converter electronics may only be performed when disconnected from the power supply.

**DANGER!**

Observe the waiting period for Ex devices.

**WARNING!**

Observe without fail the local occupational health and safety regulations. Any work done on the electrical components of the measuring device may only be carried out by properly trained specialists.



- Remove the front panel. Use a small screwdriver to open the plastic clips that hold the display.
- Remove the 2 locking screws.
- Carefully pull the electronics almost completely out of the housing.
- Remove the 2 connecting cables from the electronics before removing the signal converter electronics to be replaced.



- To insert the new electronics, first connect the 2 connecting cables to the electronics.
- Carefully push the electronics back into the housing.
- Tighten the 2 locking screws again and secure the display.

➡ The measuring system recognises the hardware replacement when the power supply is switched on.

7.2 Driver or sensor coil fault

Typical inductance and resistance values

7.2.1 VersaFlow Coriolis 100

The specified values are for guidance only.

Size	Resistance (Ω)	
	Driver	Sensor A/B
15	68	84
25	68	64
40	68	84
50	68	64

- Driver = black and grey
- Sensor A = white and yellow
- Sensor B = green and violet
- Pt500 = red and blue (530...550 Ω) at ambient temperature
- Strain values measuring tube = 420...560 Ω
- Resistance values outside of the ranges specified above may indicate a circuit error. The device may be in "start-up" mode or indicate measuring errors.
- All circuits should be isolated with respect to earth (device housing) and each other >20 M Ω .
- A driver/sensor coil short circuit may cause the meter to be in "start-up" mode.



INFORMATION!

Failure of two or more of the upper circuits may indicate a measuring tube error. There may be product in the housing. If this is the case, **depressurise** the process line and immediately remove the measuring device from the process line.

7.2.2 VersaFlow Coriolis 200

The specified values are for guidance only.

Size	Resistance (Ω)	
	Driver	Sensor A/B
100	41	108
150	46	87
250	40	87
400	46	84

- Driver = black and grey
- Sensor A = white and yellow
- Sensor B = green and violet
- Pt500 = red and blue (530...550 Ω) at ambient temperature
- Strain 1 and strain 2 values = 420...580 Ω
- Resistance values outside of the ranges specified above may indicate a circuit error. The device may be in "start-up" mode or indicate measuring errors.
- All circuits should be isolated with respect to earth (device housing) and each other >20 M Ω .
- A driver/sensor coil short circuit may cause the meter to be in "start-up" mode.



INFORMATION!

*Failure of two or more of the upper circuits may indicate a measuring tube error. There may be product in the housing. If this is the case, **depressurise** the process line and immediately remove the measuring device from the process line.*

7.2.3 VersaFlow Coriolis 6000

The specified values are for guidance only.

Size	Resistance (Ω)			
	Driver		Sensor A - Sensor B	
	black/grey		purple/green - white/yellow	
	Cryo +230°C / +446°F	+400°C / +752°F	Cryo +230°C / +446°F	+400°C / +752°F
6000 - 08	72	12	273	49
6000 - 10	68	12	273	49
6000 - 15	68	6	273	49
6000 - 25	42	12	185	22.5
6000 - 50	42	52	185	22.5
6000 - 80	42	52	185	22.5
6000 - 100	42	54	185	22.5
6000 - S150	42	70	185	22.5
6000 - S200	69	68	185	22.5

Typical RTD resistances

	Resistance (Ω)	
	Pt500	Compensation lines
	red/brown	brown/orange
6000 - all sizes	540 at +20°C / +68°F	0.1

- Resistance values outside of the ranges specified above may indicate a circuit error. The device may be in "start-up" mode or indicate measuring errors.
- All circuits should be isolated with respect to earth (device housing) and each other >20 M Ω .
- A driver/sensor coil short circuit may cause the meter to be in "start-up" mode.



INFORMATION!

Failure of two or more of the upper circuits may indicate a measuring tube error. There may be product in the housing. If this is the case, **depressurise** the process line and immediately remove the measuring device from the process line.

7.2.4 VersaFlow Coriolis 1000

The specified values are for guidance only.

Size	Resistance (Ω)	
	Driver	Sensor A/B
06 / 10	91	142
15	73	142
25	69	142
40 / 50 / 80	48	142

- Driver = black and grey
- Sensor A = white and yellow
- Sensor B = green and violet
- Pt500 = red and blue (530...550 Ω) at ambient temperature
- Resistance values outside of the ranges specified above may indicate a circuit error. The device may be in "start-up" mode or indicate measuring errors.
- All circuits should be isolated with respect to earth (device housing) and each other >20 M Ω .
- A driver/sensor coil short circuit may cause the meter to be in "start-up" mode.

Strain 1 = red and brown	VersaFlow Coriolis 1000 - all sizes	420...600 Ω at ambient temperature
Strain 2 = brown and orange	VersaFlow Coriolis 1000 - 06...10	215...300 Ω at ambient temperature
	VersaFlow Coriolis 1000 - 15...80	Short circuited



INFORMATION!

Failure of two or more of the upper circuits may indicate a measuring tube error. There may be product in the housing. If this is the case, **depressurise** the process line and immediately remove the measuring device from the process line.

7.3 Spare parts availability

The manufacturer adheres to the basic principle that functionally adequate spare parts for each device or each important accessory part will be kept available for a period of 3 years after delivery of the last production run for the device.

This regulation only applies to spare parts which are subject to wear and tear under normal operating conditions.

7.4 Availability of services

The manufacturer offers a range of services to support the customer after expiration of the warranty. These include repair, maintenance, technical support and training.



INFORMATION!

For more precise information, please contact your local sales office.

7.5 Returning the device to the manufacturer

7.5.1 General information

This device has been carefully manufactured and tested. If installed and operated in accordance with these operating instructions, it will rarely present any problems.



WARNING!

Should you nevertheless need to return a device for inspection or repair, please pay strict attention to the following points:

- *Due to statutory regulations on environmental protection and safeguarding the health and safety of the personnel, the manufacturer may only handle, test and repair returned devices that have been in contact with products without risk to personnel and environment.*
- *This means that the manufacturer can only service this device if it is accompanied by the following certificate (see next section) confirming that the device is safe to handle.*



WARNING!

If the device has been operated with toxic, caustic, radioactive, flammable or water-endangering products, you are kindly requested:

- *to check and ensure, if necessary by rinsing or neutralising, that all cavities are free from such dangerous substances,*
- *to enclose a certificate with the device confirming that it is safe to handle and stating the product used.*

7.5.2 Form (for copying) to accompany a returned device



CAUTION!

To avoid any risk for our service personnel, this form has to be accessible from outside of the packaging with the returned device.

Company:		Address:	
Department:		Name:	
Tel. no.:		Fax no. and/or Email address:	
Manufacturer's order no. or serial no.:			
The device has been operated with the following medium:			
This medium is:	<input type="checkbox"/>	radioactive	
	<input type="checkbox"/>	water-hazardous	
	<input type="checkbox"/>	toxic	
	<input type="checkbox"/>	caustic	
	<input type="checkbox"/>	flammable	
	<input type="checkbox"/>	We checked that all cavities in the device are free from such substances.	
<input type="checkbox"/>	We have flushed out and neutralized all cavities in the device.		
We hereby confirm that there is no risk to persons or the environment through any residual media contained in the device when it is returned.			
Date:		Signature:	
Stamp:			

7.6 Disposal



LEGAL NOTICE!

Disposal must be carried out in accordance with legislation applicable in your country.

Separate collection of WEEE (Waste Electrical and Electronic Equipment) in the European Union:



According to the directive 2012/19/EU, the monitoring and control instruments marked with the WEEE symbol and reaching their end-of-life **must not be disposed of with other waste**.

The user must dispose of the WEEE to a designated collection point for the recycling of WEEE or send them back to our local organisation or authorised representative.

8.1 Measuring principle

The signal converter has been designed to work with all the measuring tube designs used in the mass flowmeters. For information regarding the measuring principle for a specific measuring tube design, please refer to the technical documentation of the relevant flow sensor.

8.2 Technical data



INFORMATION!

- *The following data is provided for general applications. If you require data that is more relevant to your specific application, please contact us or your local sales office.*
- *Additional information (certificates, special tools, software,...) and complete product documentation can be downloaded free of charge from the website.*

Measuring system

Measuring principle	Coriolis principle
Application range	Measurement of mass flow, density, temperature, volume flow, flow velocity, concentration

Design

Modular construction	The measuring system consists of a flow sensor and a signal converter.
Flow sensor	
VersaFlow Coriolis 100	DN15...50 / 1/2...2"
VersaFlow Coriolis 200	DN100...400 / 4...12"
VersaFlow Coriolis 6000	DN08...250 / 3/8...10"
VersaFlow Coriolis 1000	DN06...80 / 1/4...3"
	All flow sensors are also available in an Ex version.
Signal converter	
Compact version (C)	VersaFlow Coriolis x / TWC 9400 C (x = 100, 200, 1000 or 6000)
Field housing (F) - remote version	TWC 9400 F
	Compact and field housing versions are also available in an Ex version.
Options	
Outputs / inputs	Current output (incl. HART®), pulse output, frequency output, and/or status output, limit switch and/or control input (depending on the I/O version)
Totaliser	2 (optional 3) internal totalisers with a max. of 8 counter places (e.g. for counting volume and/or mass units)
Verification	Integrated verification, diagnostic functions: measuring device, process, measured value, stabilisation
Concentration measurement	Universal concentration measurement, °Brix, °Baume, °Plato, alcohol concentration, NaOH and API density
Communication interfaces	HART®, Foundation Fieldbus, Profibus PA and DP, PROFINET IO, Modbus

Display and user interface	
Graphic display	LC display, backlit white.
	Size: 256 x 128 pixels, corresponds to 59 x 31 mm = 2.32" x 1.22"
	Display turnable in 90° steps.
	Ambient temperatures below -25°C / -13°F may affect the readability of the display.
Operating elements	4 push buttons/optical keys for operator control of the signal converter without opening the housing.
	Infrared interface for reading and writing all parameters with IR interface (option) without opening the housing.
Remote operation	PACTware™ (incl. Device Type Manager (DTM))
	HART® Hand Held Communicator from Emerson Process
	AMS® from Emerson Process
	PDM® from Siemens
	All DTMs and drivers are available free of charge from the manufacturer's website.
Display functions	
Operating menu	Setting the parameters using 2 measuring pages, 1 status page, 1 graphic page (measured values and graphics are freely adjustable)
Language display texts	Available languages: English, German, French, Danish, Spanish, Italian, Dutch, Polish, Portuguese, Swedish, Turkish
Measurement functions	Units: Metric, British and US units selectable as desired from lists for volume/mass flow and counting, velocity, temperature, pressure
	Measured values: Mass flow, total mass, temperature, density, volume flow, total volume, velocity, flow direction (not displayed unit – but available via outputs), BRIX, Baume, NaOH, Plato, API, mass concentration, volume concentration
Diagnostic functions	Standards: VDI / NAMUR / WIB 2650 and NE 107
	Status messages: Output of status messages optional via display, current and/or status output, HART® or bus interface
	Sensor and sensor electronics diagnosis: Sensor signal integrity, sensor and drive coils diagnostics, measurement channels check, comparison of internal signals with references, drive circuit integrity, process temperature, CPU diagnostics, process temperature circuit monitoring, internal data integrity check, redundant calibration
	Signal converter and inputs/outputs: Data bus monitoring, current output connections, current readback with redundant calibration, factory calibration integrity, electronics temperature, CPU diagnostics, voltage monitoring

Measuring accuracy

Reference conditions	Medium: water
	Temperature: +20°C / +68°F
	Pressure: 1 bar / 14.5 psi
Maximum measuring error	Refer to technical data for the flow sensor.

Operating conditions

Temperature	
Process temperature	Refer to technical data for the flow sensor.
Ambient temperature	Depending on the version and combination of outputs.
	It is a good idea to protect the signal converter from external heat sources such as direct sunlight as higher temperatures reduce the life cycle of all electronic components.
	Die-cast aluminium housing: SIL device: -40...+55°C / -40...+131°F Non-SIL device: -40...+60°C / -40...+140°F
	Stainless steel housing: SIL device: -40...+55°C / -40...+131°F Non-SIL device: -40...+60°C / -40...+140°F
	Ambient temperatures below -25°C / -13°F may affect the readability of the display.
Storage temperature	-40...+70°C / -40...+158°F
Pressure	
Medium	Refer to technical data for the flow sensor.
Ambient pressure	Atmospheric
Chemical properties	
State of aggregation	Liquids, gases and slurries
Flow rate	Refer to technical data for the flow sensor.
Other conditions	
Ingress protection acc. to IEC 60529	IP66/67 (acc. to NEMA 4/4X)

Installation conditions

Installation	For detailed information, refer to chapter "Installation".
Dimensions and weights	For detailed information refer to chapter "Dimensions and weights".

Materials

Signal converter housing	Standard: die-cast aluminium (polyurethane coated)
	Option: stainless steel 316 (1.4408)
Flow sensor	For housing material, process connections, measuring tubes, accessories and gaskets, refer to technical data for the flow sensor.

Electrical connection

General	Electrical connection is carried out in conformity with the VDE 0100 directive "Regulations for electrical power installations with line voltages up to 1000 V" or equivalent national specifications.
Power supply	Standard: 100...230 VAC (-15% / +10%), 50/60 Hz
	Option: 24 VDC (-55% / +30%)
Power consumption	AC: 22 VA
	DC: 12 W
Signal cable	Only for remote versions.
	10 core shielded cable. Detailed specifications are available on request.
	Length: max. 20 m / 65.6 ft
Cable entries	Standard: M20 x 1.5 (8...12 mm)
	Option: 1/2 NPT, PF 1/2

Inputs and outputs

General	All outputs are electrically isolated from each other and from all other circuits. All operating data and output values can be adjusted.	
Description of abbreviations	U_{ext} = external voltage; R_L = load + resistance; U_0 = terminal voltage; I_{nom} = nominal current Safety limit values [Ex i]: U_i = max. input voltage; I_i = max. input current; P_i = max. input power rating; C_i = max. input capacity; L_i = max. input inductivity	
Current output		
Output data	Volume flow, mass flow, temperature, density, flow velocity, diagnostic values, 2-phase signal Concentration and concentration flow are also possible with available concentration measurement (optional).	
Resolution	<1 μ A	
Uncertainty	± 5 μ A	
Temperature coefficient	Typically ± 30 ppm/K	
Settings	Without HART® $Q = 0\%$: 0...20 mA; $Q = 100\%$: 10...20 mA Alarm signal: selectable 0...22 mA With HART® $Q = 0\%$: 4...20 mA; $Q = 100\%$: 10...20 mA Alarm signal: selectable 3...22 mA	
Operating data	Modular I/Os	Ex i
Active	$U_{int, nom} = 24$ VDC $I \leq 22$ mA $R_L \leq 1$ k Ω	$U_{int, nom} = 21$ VDC $I \leq 22$ mA $R_L \leq 400$ Ω $I_0 = 90$ mA $P_0 = 0.5$ W $C_0 = 90$ nF / $L_0 = 2$ mH $C_0 = 110$ nF / $L_0 = 0.5$ mH
Passive	$U_{ext} \leq 30$ VDC $I \leq 22$ mA $U_0 \geq 1.8$ V $R_L \leq (U_{ext} - U_0) / I_{max}$	$U_{ext} \leq 30$ VDC $I \leq 22$ mA $U_0 \geq 4$ V $R_L \leq (U_{ext} - U_0) / I_{max}$ $U_i = 30$ V $I_i = 100$ mA $P_i = 1$ W $C_i = 10$ nF $L_i \sim 0$ mH

HART®		
Description	HART® protocol via active and passive current output	
	HART® version: V7	
	Universal HART® parameter: completely integrated	
Load	≥ 230 Ω at HART® test point; Note maximum load for current output!	
Multi-Drop operation	Disabled loop current mode, output current = 0%, e.g. 4 mA	
	Multi-Drop address adjustable in operation menu 0...63	
Device drivers	Available for FC 375/475, AMS, PDM, FDT/DTM	
Registration (HART Communication Foundation)	Yes	
Pulse output or frequency output		
Output data	Pulse output: volume flow, mass flow, mass or volume of dissolved substance during activated concentration measurement	
	Frequency output: flow velocity, mass flow, temperature, density, diagnostic value Optional: concentration, flow of the dissolved substance	
Function	Can be set as a pulse output or frequency output	
Pulse rate/frequency	0.01...10000 pulses/s or Hz	
Settings	Mass or volume per pulse or max. frequency for 100% flow	
	Pulse width: adjustable as automatic, symmetric or fixed (0.05...2000 ms)	
Operating data	Modular I/Os	Ex i
Active	$U_{nom} = 24 \text{ VDC}$	
	f_{max} in operating menu set to $f_{max} \leq 100 \text{ Hz}$: $I \leq 20 \text{ mA}$	
	open: $I \leq 0.05 \text{ mA}$	
	closed: $U_{0, nom} = 24 \text{ V}$ at $I = 20 \text{ mA}$	
	f_{max} in operating menu set to 100 Hz < $f_{max} \leq 10 \text{ kHz}$: $I \leq 20 \text{ mA}$	
	open: $I \leq 0.05 \text{ mA}$	
	closed: $U_{0, nom} = 22.5 \text{ V}$ at $I = 1 \text{ mA}$ $U_{0, nom} = 21.5 \text{ V}$ at $I = 10 \text{ mA}$ $U_{0, nom} = 19 \text{ V}$ at $I = 20 \text{ mA}$	

Passive	$U_{\text{ext}} \leq 32 \text{ VDC}$	-
	f_{max} in operating menu set to $f_{\text{max}} \leq 100 \text{ Hz}$: $I \leq 100 \text{ mA}$ open: $I \leq 0.05 \text{ mA}$ at $U_{\text{ext}} = 32 \text{ VDC}$ closed: $U_{0, \text{max}} = 0.2 \text{ V}$ at $I \leq 10 \text{ mA}$ $U_{0, \text{max}} = 2 \text{ V}$ at $I \leq 100 \text{ mA}$	
	f_{max} in operating menu set to $100 \text{ Hz} <$ $f_{\text{max}} \leq 10 \text{ kHz}$: $I \leq 20 \text{ mA}$ open: $I \leq 0.05 \text{ mA}$ at $U_{\text{ext}} = 32 \text{ VDC}$ closed: $U_{0, \text{max}} = 1.5 \text{ V}$ at $I \leq 1 \text{ mA}$ $U_{0, \text{max}} = 2.5 \text{ V}$ at $I \leq 10 \text{ mA}$ $U_{0, \text{max}} = 5.0 \text{ V}$ at $I \leq 20 \text{ mA}$	
NAMUR	Passive to EN 60947-5-6 $U_{\text{ext}} = 8.2 \text{ V} \pm 0.1 \text{ VDC}$ $R = 1 \text{ k}\Omega \pm 10 \Omega$ open: $I_{\text{nom}} = 0.6 \text{ mA}$ closed: $I_{\text{nom}} = 3.8 \text{ mA}$	Passive to EN 60947-5-6 open: $I_{\text{nom}} = 0.43 \text{ mA}$ closed: $I_{\text{nom}} = 4.5 \text{ mA}$
		$U_i = 30 \text{ V}$ $I_i = 100 \text{ mA}$ $P_i = 1 \text{ W}$ $C_i = 10 \text{ nF}$ $L_i \sim 0 \text{ mH}$
Low flow cut off		
Function	Switching point and hysteresis separately adjustable for each output, counter and the display	
Switching point	Set in increments of 0.1%.	
	0...20% (current output, frequency output)	
Hysteresis	Set in increments of 0.1%.	
	0...20% (current output, frequency output)	
Damping		
Function	The time constant corresponds to the elapsed time until 63% of the end value has been reached according to a step function.	
Settings	Set in increments of 0.1 seconds.	
	0...100 seconds	

Status output / limit switch		
Function and settings	Adjustable as automatic measuring range conversion, display of flow direction, overflow, error or switching point.	
	Valve control with activated dosing function	
	Status and/or control: ON or OFF	
Operating data	Modular I/Os	Ex i
Active	$U_{int} = 24 \text{ VDC}$ $I \leq 20 \text{ mA}$ open: $I \leq 0.05 \text{ mA}$ closed: $U_{0, nom} = 24 \text{ V at } I = 20 \text{ mA}$	-
Passive	$U_{ext} \leq 32 \text{ VDC}$ $I \leq 100 \text{ mA}$ $R_{L, max} = 47 \text{ k}\Omega$ $R_{L, min} = (U_{ext} - U_0) / I_{max}$ open: $I \leq 0.05 \text{ mA at } U_{ext} = 32 \text{ VDC}$ closed: $U_{0, max} = 0.2 \text{ V at } I \leq 10 \text{ mA}$ $U_{0, max} = 2 \text{ V at } I \leq 100 \text{ mA}$	-
NAMUR	Passive to EN 60947-5-6 $U_{ext} = 8.2 \text{ V} \pm 0.1 \text{ VDC}$ $R = 1 \text{ k}\Omega \pm 10 \Omega$ open: $I_{nom} = 0.6 \text{ mA}$ closed: $I_{nom} = 3.8 \text{ mA}$	Passive to EN 60947-5-6 open: $I_{nom} = 0.43 \text{ mA}$ closed: $I_{nom} = 4.5 \text{ mA}$ $U_i = 30 \text{ V}$ $I_i = 100 \text{ mA}$ $P_i = 1 \text{ W}$ $C_i = 10 \text{ nF}$ $L_i = 0 \text{ mH}$

Control input		
Function	Hold value of the outputs (e.g. for cleaning work), set value of the outputs to "zero", counter and error reset, stop counter, range conversion, zero calibration	
	Start of dosing when dosing function is activated.	
Operating data	Modular I/Os	Ex i
Active	$U_{int} = 24 \text{ VDC}$ External contact open: $U_{0, nom} = 22 \text{ V}$ External contact closed: $I_{nom} = 4 \text{ mA}$ Contact open (off): $U_0 \geq 12 \text{ V}$ with $I_{nom} = 1.9 \text{ mA}$ Contact closed (on): $U_0 \leq 10 \text{ V}$ with $I_{nom} = 1.9 \text{ mA}$	-
Passive	$3 \text{ V} \leq U_{ext} \leq 32 \text{ VDC}$ $I_{max} = 9.5 \text{ mA}$ at $U_{ext} \leq 24 \text{ V}$ $I_{max} = 9.5 \text{ mA}$ at $U_{ext} \leq 32 \text{ V}$ Contact closed (on): $U_0 \geq 3 \text{ V}$ with $I_{nom} = 1.9 \text{ mA}$ Contact open (off): $U_0 \leq 2.5 \text{ V}$ with $I_{nom} = 1.9 \text{ mA}$	$U_{ext} \leq 32 \text{ VDC}$ $I \leq 6 \text{ mA}$ at $U_{ext} = 24 \text{ V}$ $I \leq 6.5 \text{ mA}$ at $U_{ext} = 32 \text{ V}$ On: $U_0 \geq 5.5 \text{ V}$ with $I \geq 4 \text{ mA}$ Off: $U_0 \leq 3.5 \text{ V}$ with $I \leq 0.5 \text{ mA}$ $U_i = 30 \text{ V}$ $I_i = 100 \text{ mA}$ $P_i = 1 \text{ W}$ $C_i = 10 \text{ nF}$ $L_i = 0 \text{ mH}$
NAMUR	Active to EN 60947-5-6 Terminals open: $U_{0, nom} = 8.7 \text{ V}$ Contact closed (on): $U_{0, nom} = 6.3 \text{ V}$ with $I_{nom} > 1.9 \text{ mA}$ Contact open (off): $U_{0, nom} = 6.3 \text{ V}$ with $I_{nom} < 1.9 \text{ mA}$ Detection of cable break: $U_0 \geq 8.1 \text{ V}$ with $I \leq 0.1 \text{ mA}$ Detection of cable short circuit: $U_0 \leq 1.2 \text{ V}$ with $I \geq 6.7 \text{ mA}$	-

PROFIBUS DP	
Description	Galvanically isolated acc. to IEC 61158
	Profile version: 3.02
	Automatic data transmission rate recognition (max. 12 MBaud)
	Bus address adjustable via local display at the measuring device
Function blocks	8 x analogue input, 3 x totaliser
Output data	Mass flow, volume flow, mass counter 1 + 2, volume counter, product temperature, several concentration measurements and diagnostic data
PROFIBUS PA	
Description	Galvanically isolated acc. to IEC 61158
	Profile version: 3.02
	Current consumption: 10.5 mA
	Permissible bus voltage: 9...32 V; in Ex application: 9...24 V
	Bus interface with integrated reverse polarity protection
	Typical error current FDE (Fault Disconnection Electronic): 4.3 mA
	Bus address adjustable via local display at the measuring device
Function blocks	8 x analogue input, 3 x totaliser
Output data	Mass flow, volume flow, mass counter 1 + 2, volume counter, product temperature, several concentration measurements and diagnostic data
FOUNDATION Fieldbus	
Description	Galvanically isolated acc. to IEC 61158
	Current consumption: 10.5 mA
	Permissible bus voltage: 9...32 V; in Ex application: 9...24 V
	Bus interface with integrated reverse polarity protection
	Link Master function (LM) supported
	Tested with Interoperable Test Kit (ITK) version 6.01
Function blocks	6 x analogue input, 2 x integrator, 1 x PID
Output data	Mass flow, volume flow, density, temperature of tube, several concentration measurements and diagnostic data
Modbus	
Description	Modbus RTU, Master/Slave, RS485
Address range	1...247
Supported function codes	01, 03, 04, 05, 08, 16, 43
Supported Baud rate	1200, 2400, 3600, 4800, 9600, 19200, 38400, 57600, 115200 Baud

Approvals and certificates

CE	This device fulfils the statutory requirements of the relevant EU directives. The manufacturer certifies successful testing of the product by applying the CE mark.
	For full information of the EU directives & standards and the approved certifications, please refer to the CE declaration or the manufacturer website.
Non-Ex	Standard
Functional safety acc. to EN 61508	Depends on I/O variant and flow sensor. For detailed information refer to the "Safety manual".
Hazardous areas	
Option (C version only)	
ATEX	II 1/2 (1) G - Ex d ia [ia Ga] IIC T6 Ga/Gb
	II 1/2 (1) G - Ex de ia [ia Ga] IIC T6...T1 Ga/Gb
	II 2 (1) G - Ex d ia [ia Ga] IIC T6...T1 Gb
	II 2 (1) G - Ex de ia [ia Ga] IIC T6...T1 Gb
	II 2 (1) D - Ex t [ia Da] IIIC Txxx Db
	II 1/2 G - Ex d ia IIC T6...T1 Ga/Gb; II 1/2 G - Ex de ia IIC T6...T1 Ga/Gb
	II 2 G - Ex d ia IIC T6...T1 Gb; II 2 G - Ex de ia IIC T6...T1 Gb
II 2 D - Ex t IIIC Txxx°C Db	
Option (F version only)	
ATEX	II 2 (1) G - Ex d [ia Ga] IIC T6 Gb
	II 2 (1) G - Ex de [ia Ga] IIC T6 Gb
	II 2 (1) D - Ex t [ia Da] IIIC T75°C Db
	II 2 G - Ex d [ia] IIC T6 Gb; II 2 G - Ex de [ia] IIC T6 Gb
	II 2 D - Ex t IIIC T75 Db
NEPSI	Ex d ia [ia Ga] IIC T6...T1 Ga/Gb; Ex de ia [ia Ga] IIC T6...T1 Ga/Gb
Option	
FM / CSA	FM: Class I, Div 1 groups A, B, C, D CSA: Class I, Div 1 groups C, D
	Class II, Div 1 groups E, F, G
	Class III, Div 1 hazardous areas
	FM: Class I, Div 2 groups A, B, C, D CSA: Class I, Div 2 groups C, D
	Class II, Div 2 groups E, F, G
Class III, Div 2 hazardous areas	
IECEx	Ex zone 1 + 2
Custody transfer	
Without	Standard
Option (in preparation)	Liquids other than water 2004/22/EC (MID MI005) acc. to OIML R117-1
	Gases 2004/22/EC (MID MI002) acc. to OIML R137
	Compliance with API and AGA
Other standards and approvals	
Vibration resistance	IEC 60068-2-6 10 cycles 10-150-10 Hz with: 0.15 mm for 10-60 Hz and 20 m/s ² for 60-150 Hz
NAMUR	NE 21, NE 43, NE 53, NE 107

8.3 Dimensions and weight

8.3.1 Housing

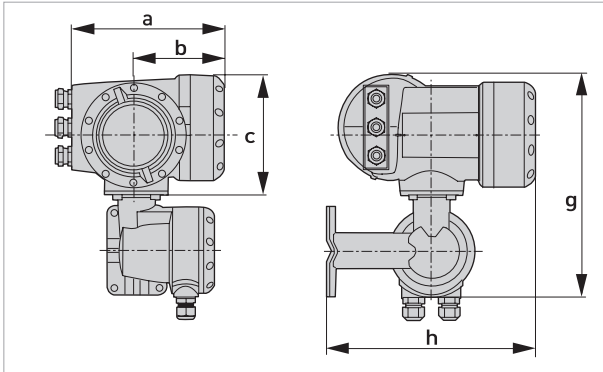


Figure 8-1: Dimensions for field housing (F) - remote version

Dimensions [mm / inch]					Weight [kg / lb]
a	b	c	g	h	
202 / 7.75	120 / 4.75	155 / 6.10	295.8 / 11.60	277 / 10.90	5.7 / 12.60

Table 8-1: Dimensions and weight

8.3.2 Mounting plate of field housing

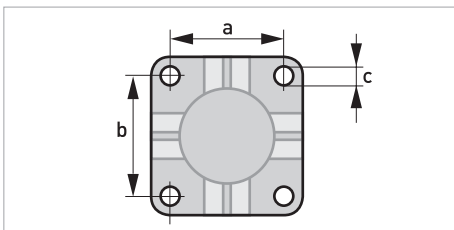


Figure 8-2: Dimensions for mounting plate of field housing

	[mm]	[inch]
a	72	2.8
b	72	2.8
c	Ø9	Ø0.4

Table 8-2: Dimensions in mm and inch

9.1 General description

The open HART[®] protocol, which can be used freely, is integrated into the signal converter for communication.

Devices which support the HART[®] protocol are classified as either operating devices or field devices. When it comes to operating devices (Master), both manual control units (Secondary Master) and PC-supported workstations (Primary Master) are used in, for example, a control centre.

HART[®] field devices include flow sensors, signal converters and actuators. The field devices range from 2-wire to 4-wire to intrinsically safe versions for use in hazardous areas.

The HART[®] data are superimposed over the analogue 4...20 mA signal via FSK modem. This way, all of the connected devices can communicate digitally with one another via the HART[®] protocol while simultaneously transmitting the analogue signals.

When it comes to the field devices and secondary masters, the FSK or HART[®] modem is integrated, whereas with a PC communication takes place via an external modem which must be connected to the serial interface. There are, however, other connection variants which can be seen in the following connection figures.

9.2 Software history



INFORMATION!

In the table below, "x" is a place holder for possible multi-digit alphanumeric combinations, depending on the available version.

Release date	Electronic Revision	HART [®]	
		Device Revision	DD Revision
2016-07-01	ER 2.0.0x	1	1

HART[®] identification codes and revision numbers

Manufacturer ID:	69 [0x45]
Extended Device Type:	0x45BB
Device Revision:	1
DD Revision:	1
HART [®] Universal Revision:	7
FC 375/475 system SW.Rev.:	≥ 3.3
AMS version:	≥ 8.0
PDM version:	≥ 6.0
FDT version:	≥ 1.2

9.3 Connection variants

The signal converter is a 4-wire device with 4...20 mA current output and HART[®] interface. Depending on the version, the settings and the wiring, the current output can operate as passive or active output.

- **Multi-Drop Mode is supported**
In a Multi-Drop communication system, more than 2 devices are connected to a common transmission cable.
- **Burst Mode is not supported**
In the Burst Mode a slave device transfers cyclic pre-defined response telegrams, to get a higher rate of data transfer.



INFORMATION!

For detailed information about the electrical connection of the signal converter for HART[®], refer to the section "Electrical connection".

There are two ways of using the HART[®] communication:

- as Point-to-Point connection and
- as multi-drop connection, with 2-wire connection or as multi-drop connection, with 3-wire connection.

9.3.1 Point-to-Point connection - analogue / digital mode

Point-to-Point connection between the signal converter and the HART[®] Master.

The current output of the device may be active or passive.

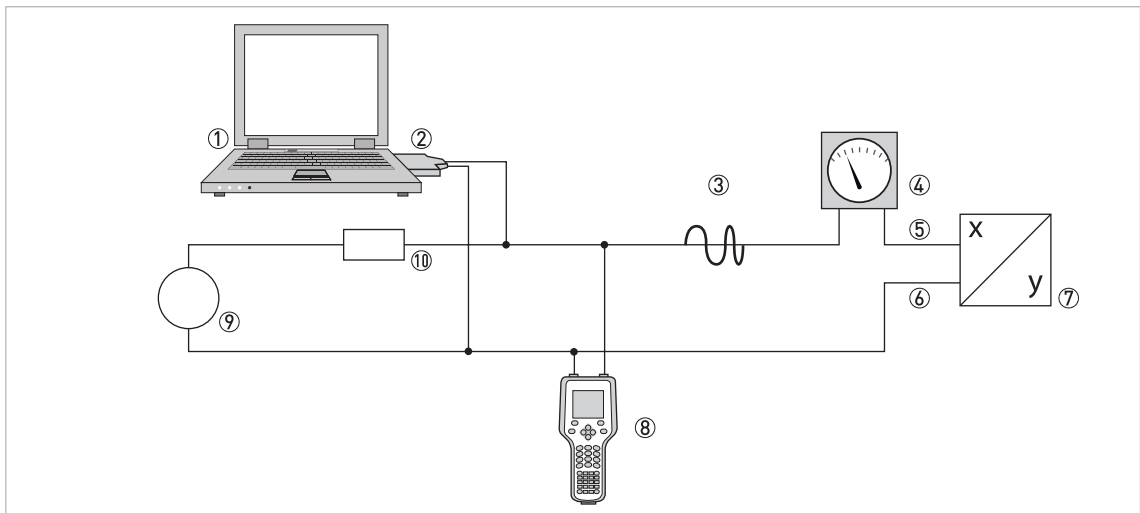


Figure 9-1: Point-to-Point connection

- ① Primary master
- ② FSK modem or HART[®] modem
- ③ HART[®] signal
- ④ Analogue indication
- ⑤ Signal converter terminals C
- ⑥ Signal converter terminals C-
- ⑦ Signal converter with address = 0 and passive or active current output
- ⑧ Secondary Master
- ⑨ Power supply for devices (slaves) with passive current output
- ⑩ Load $\geq 230 \Omega$

9.3.2 Multi-Drop connection (2-wire connection)

In the case of a multi-drop connection, up to 15 devices may be installed in parallel (this signal converter and other HART[®] devices).

The current outputs of the devices must be passive!

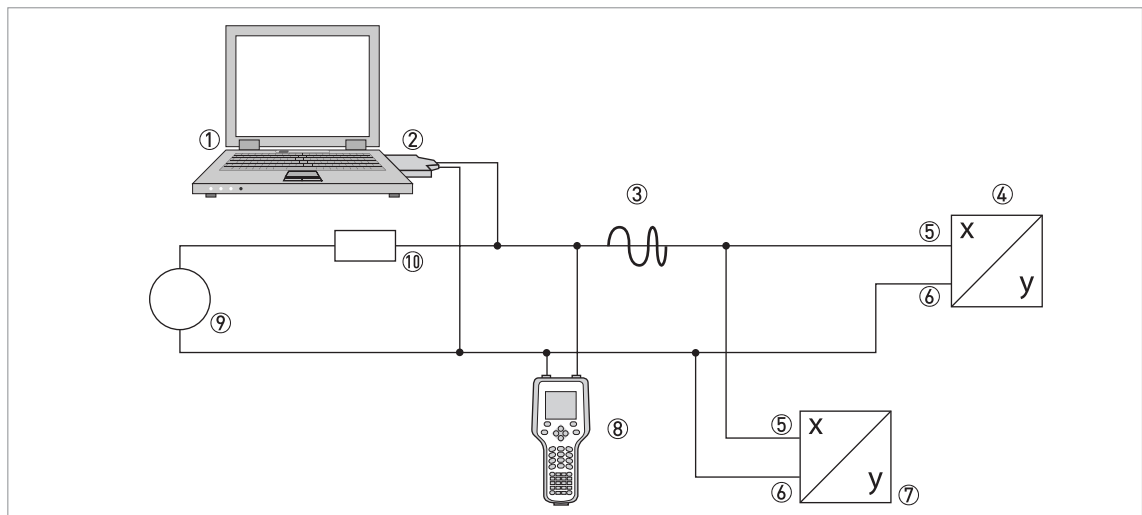


Figure 9-2: Multi-Drop connection (2-wire connection)

- ① Primary Master
- ② HART[®] modem
- ③ HART[®] signal
- ④ Other HART[®] devices or this signal converter (refer also to ⑦)
- ⑤ Signal converter terminals C
- ⑥ Signal converter terminals C-
- ⑦ Signal converter with address > 0 and passive current output, connection of max. 15 devices (slaves) with 4...20 mA
- ⑧ Secondary Master
- ⑨ Power supply
- ⑩ Load $\geq 230 \Omega$

9.3.3 Multi-Drop connection (3-wire connection)

Connection of 2-wire and 4-wire devices in the same network. In order that the current output of the signal converter is working continuously active, an additional third wire must be connected to the devices in the same network. These devices must be powered via a 2-wire loop.

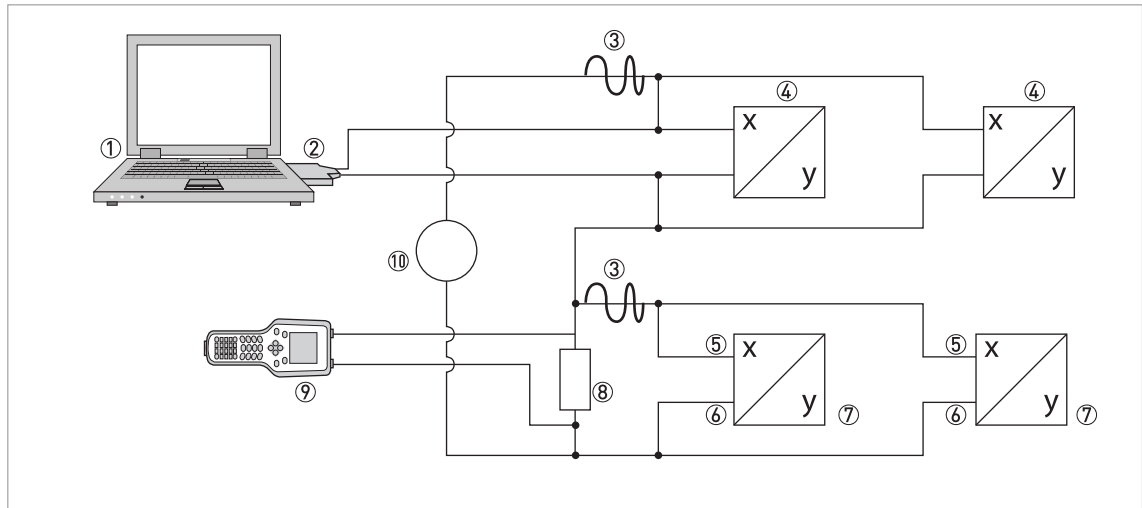


Figure 9-3: Multi-Drop connection (3-wire connection)

- ① Primary Master
- ② HART[®] modem
- ③ HART[®] signal
- ④ 2-wire external devices (slaves) with 4...20 mA, addresses > 0, powered by current loop
- ⑤ Signal converter terminals C
- ⑥ Signal converter terminals C-
- ⑦ Connection of active or passive 4-wire devices (slaves) with 4...20 mA, addresses > 0
- ⑧ Load $\geq 230 \Omega$
- ⑨ Secondary Master
- ⑩ Power supply

9.4 Inputs/outputs and HART[®] dynamic variables and device variables

The signal converter is available with various input/output combinations.

The connection of the terminals A...D to the HART[®] dynamic variables PV, SV, TV and 4V depends on the device version.

PV = Primary Variable; SV = Secondary Variable; TV = Tertiary Variable; 4V = Fourth Variable

Signal converter version	HART [®] dynamic variable			
	PV	SV	TV	4V
Modular I/O and Ex i I/O, connection terminals	C	D	A	B

Table 9-1: Connection of the terminals to the HART[®] dynamic variables

The signal converter can provide up to 24 measurement-related values. The measured values are accessible as so-called HART[®] device variables and can be connected to the HART[®] dynamic variables. The availability of these variables depends on the device versions and the settings.

Code = device variable code

HART [®] device variable	Code	Type	Explanations
Flow Velocity	0	linear	
Volume Flow	1	linear	
Mass Flow	2	linear	
Temperature	3	linear	
Density	4	linear	
Sensor Average	5	linear	Diagnostic value, optional, available when one of the diagnostic channels (1 or 2) is set to "Sensor Average".
Sensor Deviation	6	linear	Diagnostic value, optional, available when one of the diagnostic channels (1 or 2) is set to "Sensor Deviation".
Drive Level	7	linear	Diagnostic value, optional, available when one of the diagnostic channels (1 or 2) is set to "Drive Level".
Tube Frequency	8	linear	Diagnostic value, optional, available when one of the diagnostic channels (1 or 2) is set to "Tube Frequency".
	9	linear	
	10	linear	
2 Phase Signal	11	linear	Diagnostic value, optional, available when one of the diagnostic channels (1 or 2) is set to "2 Phase Signal".
Concentration 1	12	linear	Available when concentration measurement is switched on.
Concentration 2	13	linear	Available when concentration measurement is switched on and Concentration 2 is not switched off.

HART® device variable	Code	Type	Explanations
Concentration Flow 1 Mass	14	linear	Available when concentration measurement is switched on and concentration mode 1 does not measure % volume or % alcohol per volume.
Concentration Flow 1 Volume	15	linear	Available when concentration measurement is switched on and Concentration mode 1 measures % volume or % alcohol per volume.
Concentration Flow 2 Mass	16	linear	Available when concentration measurement is switched on and Concentration 2 is not switched off and Concentration mode 1 does not measure % volume or % alcohol per volume.
Concentration Flow 2 Volume	17	linear	Available when concentration measurement is switched on and Concentration 2 is not switched off and Concentration mode 2 measures % volume or % alcohol per volume.
Totaliser 1 Mass	18	Totaliser	
Totaliser 1 Volume	19	Totaliser	
Totaliser 2 Mass	20	Totaliser	
Totaliser 2 Volume	21	Totaliser	
Totaliser 3 Mass	22	Totaliser	Depends on hardware configuration
Totaliser 3 Volume	23	Totaliser	Depends on hardware configuration

Table 9-2: Description of the HART® device variables

For the dynamic variables connected to the linear analogue outputs for current and/or frequency, the assignment of the device variables takes place by selecting the linear measurement for these outputs under the appropriate function of the signal converter. It follows that the dynamic variables connected to current or frequency outputs can only be assigned to the linear HART® device variables.

The HART® dynamic variable PV is always connected to the HART® current output.

A totaliser device variable can thus not be assigned to the dynamic variable PV because the PV is always connected to the HART® current output.

Such correlations do not exist for dynamic variables not connected to linear analogue outputs. Both linear and totaliser device variables can be assigned.

The totaliser device variables can only be assigned to the dynamic variables SV, TV and 4V if the connected output is not a current or frequency output.



Honeywell

AUTHORIZED DISTRIBUTOR

De Gidts & Feldman BV
The Netherlands
w w w . d g f g . n l



De Gidts & Feldman

INSTRUMENTATION & FILTRATION

Honeywell Process Solutions
1250 W Sam Houston Pkwy S
Houston, TX 77042
www.honeywellprocess.com

© Honeywell International Inc.
Subject to change without notice.