



VERSAFLOW SONIC 2000 / TWS 2000 Handbook

Portable ultrasonic clamp-on flowmeter

Electronic Revision:
ER 1.0.1
(SW.REV 01.01.01_)

Notices and Trademarks

Copyright 2013 by Honeywell

WARRANTY/REMEDY

Honeywell warrants goods of its manufacture as being free of defective materials and faulty workmanship. Contact your local sales office for warranty information. If warranted goods are returned to Honeywell during the period of coverage, Honeywell will repair or replace without charge those items it finds defective. The foregoing is Buyer's sole remedy and is in lieu of all other warranties, expressed or implied, including those of merchantability and fitness for a particular purpose. Specifications may change without notice. The information we supply is believed to be accurate and reliable as of this printing. However, we assume no responsibility for its use.

While we provide application assistance personally, through our literature and the Honeywell web site, it is up to the customer to determine the suitability of the product in the application.

Honeywell Field Solutions
512 Virginia Drive
Fort Washington, PA 19034

Abstract

This document provides descriptions and procedures for the Installation, Configuration, Operation, and Troubleshooting of your device.

Contacts

World Wide Web:

The following lists Honeywell’s World Wide Web sites that will be of interest to our customers.

Honeywell Organization

Corporate
 Field Solutions
 Technical tips

WWW Address (URL)

<http://www.honeywell.com>
<http://www.honeywell.com/ps>
<http://content.honeywell.com/ipc/faq>

Telephone:

Contact us by telephone at the numbers listed below.

Organization

United States and Honeywell
 Canada

Phone Number

Tech. Support: 1-800-423-9883
Service: 1-800-525-7439

1	Safety instructions	7
<hr/>		
1.1	Intended use	7
1.2	Certification	7
1.3	Safety instructions from the manufacturer	8
1.3.1	Copyright and data protection	8
1.3.2	Disclaimer	8
1.3.3	Product liability and warranty	9
1.3.4	Information concerning the documentation	9
1.3.5	Warnings and symbols used	10
2	Device description	11
<hr/>		
2.1	Scope of delivery	11
2.2	Nameplates	12
3	Install for flow measurement	15
<hr/>		
3.1	General safety instructions	15
3.2	Step 1: Find location and determine data	16
3.3	Step 2: Initialise the TWS 2000 converter	20
3.4	Step 3: Mount the sensor rails	26
3.4.1	2 or 4 traverses with 1 rail	29
3.4.2	2 traverses with 2 rails	30
3.4.3	1 traverse with 2 rails (DN400...1500)	31
3.4.4	Apply coupling grease	32
3.4.5	Connect the sensor cable	33
3.5	Step 4: Optimization loop	34
3.6	Step 5: start flow measurement	35
3.7	Error messages	36
4	Install for energy measurement	39
<hr/>		
4.1	Preparation of energy measurement	39
4.2	Mechanical installation	40
4.3	Program the converter	42
4.3.1	Program the I/O input	42
4.3.2	Program the process input	43
4.3.3	Program the counters	44
4.4	Start measurement	45

5	Electrical connections	47
<hr/>		
5.1	Safety instructions.....	47
5.2	Location of connectors at the converter	47
5.3	Power supply	48
5.4	Signal cable	48
5.5	USB connector.....	49
5.6	I/O cable.....	51
5.7	Connection diagrams	52
6	Operation	57
<hr/>		
6.1	Display configuration.....	57
6.1.1	Step 1: how to set up the display for showing measured values.....	57
6.1.2	Basic settings of display	58
6.2	Programming the transducer calibration number.....	59
6.3	Data logging.....	60
6.3.1	Step 1: how to set up the data logger.....	60
6.3.2	Step 2: how to start data logging.....	63
6.3.3	Step 3: how to view logged data.....	63
6.4	How to transfer data to a PC	64
6.4.1	Site files.....	64
6.4.2	Log files.....	65
6.4.3	Managing your files from your pc.....	66
6.5	Menu description	67
7	Service	79
<hr/>		
7.1	Spare parts availability.....	79
7.2	Availability of services	79
7.3	Returning the device to the manufacturer.....	79
7.3.1	General information.....	79
7.3.2	Form (for copying) to accompany a returned device.....	80
7.4	Disposal	80
8	Technical data	81
<hr/>		
8.1	Measuring principle.....	81
8.2	Technical data.....	82
8.3	Dimensions and weights	88
8.3.1	Clamp-on sensor	88
8.3.2	Converter.....	89
8.3.3	I/O box	90
8.3.4	Trunk on wheels.....	91
9	Technical data	93
<hr/>		

1.1 Intended use

**CAUTION!**

Responsibility for the use of the measuring devices with regard to suitability, intended use and corrosion resistance of the used materials against the measured fluid lies solely with the operator.

**INFORMATION!**

The manufacturer is not liable for any damage resulting from improper use or use for other than the intended purpose.

The **VersaFlow Sonic 2000 / TWS 2000** portable clamp-on flow meter is designed for measurement of liquid flows in full pipes, datalogging and transfer of logged results to the PC. The portable clamp-on flow meter makes it possible to measure the flow on places temporary or you can make use of it if you want to compare the output with other measurement devices. If an inline measurement device is broken and you are in need of the information the VersaFlow Sonic 2000 / TWS 2000 might be the solution for you.

1.2 Certification



In accordance with the commitment to customer service and safety, the device described in this document meets the following safety requirements:

- EMC Directive 2004/108/EC and 93/68/EEC in conjunction with EN 61326-1 (1997) and A1 (1998), A2 (2001)
- Low-Voltage Directives 73/23/EEC and 93/68/EEC in conjunction with EN 61010-1 (2001)

1.3 Safety instructions from the manufacturer

1.3.1 Copyright and data protection

The contents of this document have been created with great care. Nevertheless, we provide no guarantee that the contents are correct, complete or up-to-date.

The contents and works in this document are subject to copyright. Contributions from third parties are identified as such. Reproduction, processing, dissemination and any type of use beyond what is permitted under copyright requires written authorisation from the respective author and/or the manufacturer.

The manufacturer tries always to observe the copyrights of others, and to draw on works created in-house or works in the public domain.

The collection of personal data (such as names, street addresses or e-mail addresses) in the manufacturer's documents is always on a voluntary basis whenever possible. Whenever feasible, it is always possible to make use of the offerings and services without providing any personal data.

We draw your attention to the fact that data transmission over the Internet (e.g. when communicating by e-mail) may involve gaps in security. It is not possible to protect such data completely against access by third parties.

We hereby expressly prohibit the use of the contact data published as part of our duty to publish an imprint for the purpose of sending us any advertising or informational materials that we have not expressly requested.

1.3.2 Disclaimer

The manufacturer will not be liable for any damage of any kind by using its product, including, but not limited to direct, indirect or incidental and consequential damages.

This disclaimer does not apply in case the manufacturer has acted on purpose or with gross negligence. In the event any applicable law does not allow such limitations on implied warranties or the exclusion of limitation of certain damages, you may, if such law applies to you, not be subject to some or all of the above disclaimer, exclusions or limitations.

Any product purchased from the manufacturer is warranted in accordance with the relevant product documentation and our Terms and Conditions of Sale.

The manufacturer reserves the right to alter the content of its documents, including this disclaimer in any way, at any time, for any reason, without prior notification, and will not be liable in any way for possible consequences of such changes.

1.3.3 Product liability and warranty

The operator shall bear responsibility for the suitability of the device for the specific purpose. The manufacturer accepts no liability for the consequences of misuse by the operator. Improper installation and operation of the devices (systems) will cause the warranty to be void. The respective "Standard Terms and Conditions" which form the basis for the sales contract shall also apply.

1.3.4 Information concerning the documentation

To prevent any injury to the user or damage to the device it is essential that you read the information in this document and observe applicable national standards, safety requirements and accident prevention regulations.

If this document is not in your native language and if you have any problems understanding the text, we advise you to contact your local office for assistance. The manufacturer can not accept responsibility for any damage or injury caused by misunderstanding of the information in this document.

This document is provided to help you establish operating conditions, which will permit safe and efficient use of this device. Special considerations and precautions are also described in the document, which appear in the form of underneath icons.

1.3.5 Warnings and symbols used

Safety warnings are indicated by the following symbols.

**DANGER!**

This information refers to the immediate danger when working with electricity.

**DANGER!**

This warning refers to the immediate danger of burns caused by heat or hot surfaces.

**DANGER!**

This warning refers to the immediate danger when using this device in a hazardous atmosphere.

**DANGER!**

These warnings must be observed without fail. Even partial disregard of this warning can lead to serious health problems and even death. There is also the risk of seriously damaging the device or parts of the operator's plant.

**WARNING!**

Disregarding this safety warning, even if only in part, poses the risk of serious health problems. There is also the risk of damaging the device or parts of the operator's plant.

**CAUTION!**

Disregarding these instructions can result in damage to the device or to parts of the operator's plant.

**INFORMATION!**

These instructions contain important information for the handling of the device.

**LEGAL NOTICE!**

This note contains information on statutory directives and standards.

• **HANDLING**

This symbol designates all instructions for actions to be carried out by the operator in the specified sequence.

➔ **RESULT**

This symbol refers to all important consequences of the previous actions.

2.1 Scope of delivery



INFORMATION!

Do a check of the packing list to make sure that you have all the elements given in the order.



INFORMATION!

Inspect the cartons carefully for damages or signs of rough handling. Report damage to the carrier and to the local office of the manufacturer.



CAUTION!

The device arrives in a plastic trunk on wheels, unless ordered otherwise.

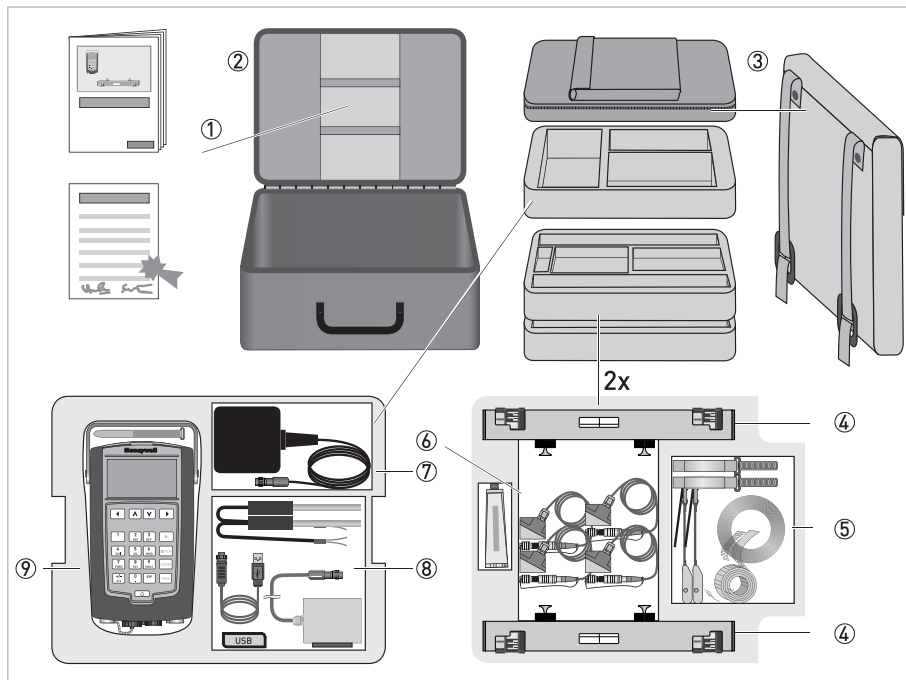

Figure 2-1: Scope of delivery

- ① Product documentation, factory calibration report
- ② Trunk on wheels
- ③ Carrying bag
- ④ Tray with one or two rails
- ⑤ Metal / textile straps for mounting rail(s) and converter
- ⑥ Sensor(s) with fixing units (small version 1, medium version 2 sensors)
2 Transducers (small versions: 2 MHz, medium version: 1 MHz), including 3 m cable, coupling grease
- ⑦ Power adapter including plugs for EU, UK, US and AUS
- ⑧ USB memory stick, measure band
optionally I/O box and/or temperature sensors, PC connection cable
- ⑨ TWS 2000 Signal converter



INFORMATION!

Delivered content can be different, dependent on the ordered version. A checklist is included with the product, check if all items on this checklist are delivered.

2.2 Nameplates

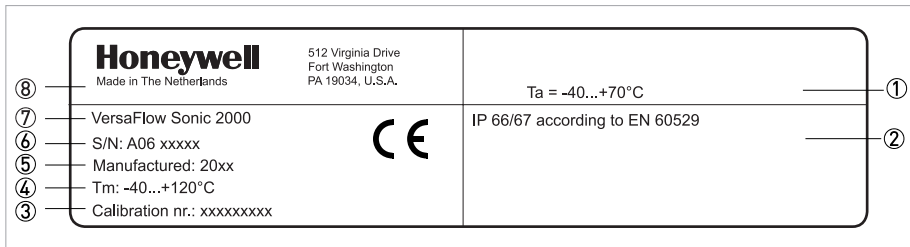

Figure 2-2: Nameplate flow sensor

- ① Ambient temperature operating range
- ② Protection category
- ③ Calibration number
- ④ Process temperature [-40...+200°C for XT version]
- ⑤ Manufacturing year
- ⑥ Serial number
- ⑦ Device type (yyy = small, medium or large)
- ⑧ Name and address of the manufacturer

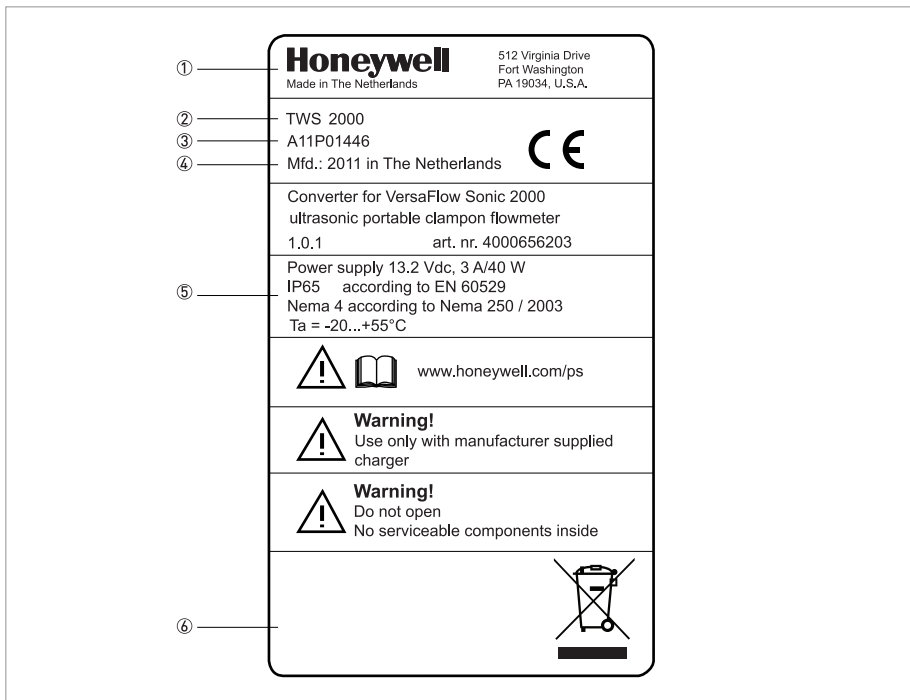

Figure 2-3: Nameplate converter

- ① Name and address of the manufacturer
- ② Device type
- ③ Serial number
- ④ Manufacturing year
- ⑤ Protection class and temperature data
- ⑥ Treat device as electronic garbage according WEEE rules.

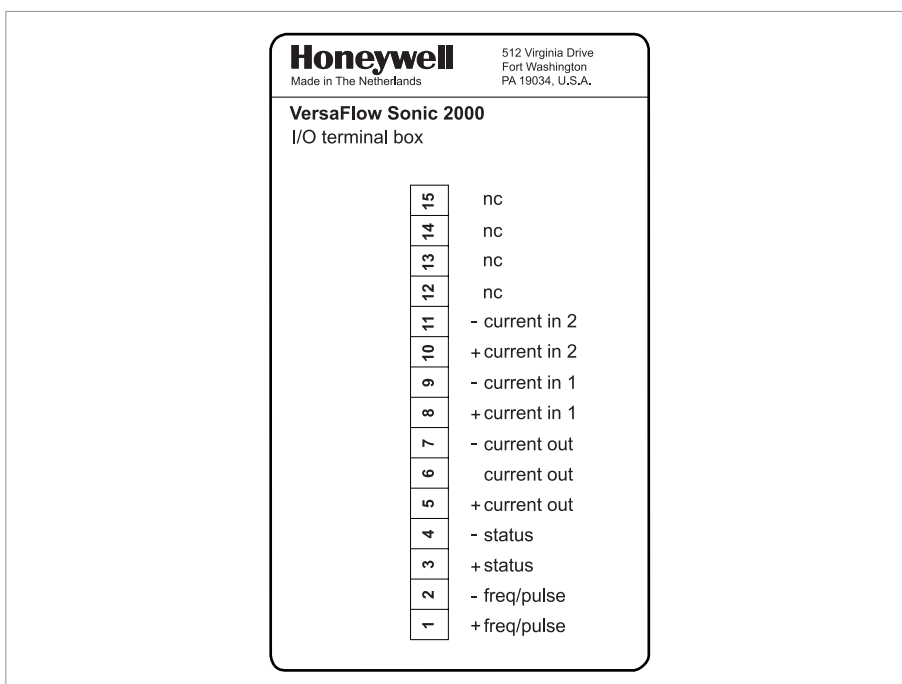

Figure 2-4: Nameplate I/O box, standard version

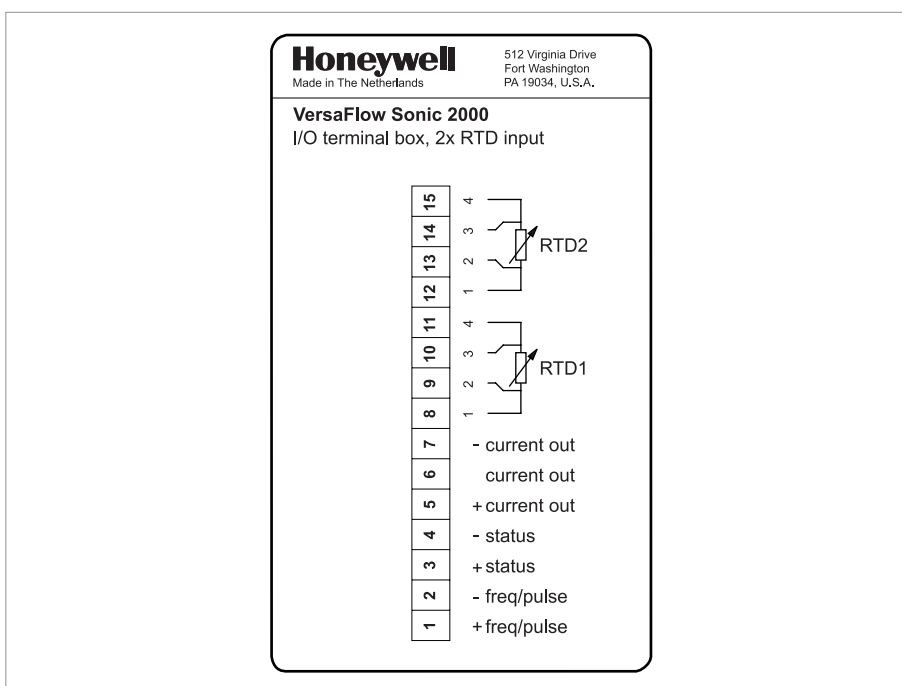

Figure 2-5: Nameplate I/O box with 2 temperature transmitters included.

**INFORMATION!**

Four steps are needed to start a measurement on a new location:

1. Find a suitable location and determine some basic data of the pipe.
 2. Initialise the converter and enter the data from step 1. The converter advises a measurement mode.
 3. Mount the sensor rails as advised for the chosen measurement mode.
 4. Perform an optimisation loop and make small changes in the position of the transducers.
- These four steps are described in section 3.2...3.5.

3.1 General safety instructions

**WARNING!**

In general, devices from the manufacturer may only be installed, commissioned, operated and maintained by properly trained and authorized personnel.

This document is provided to help you establish operating conditions, which will permit safe and efficient use of this device.

Specific for sensors:**WARNING!**

- Be careful when locking the rail back on to the mounting units as your fingers may get stuck between rail and pipe it is mounted on. This may cause injury.
- Be careful when mounting the fixation units using the metal strap. The edge of the strap may cause injury.

**CAUTION!**

- Do not bend the metal mounting strap. This may cause improper mounting of the fixation units of the sensor rails.
- Protect the pipe contact side of the transducer. Scratches or other damages may have a negative impact on its proper functioning.
- Before fitting the transducer to the transducer knob in the sensor rail, check the connection groove of the transducer cover for damages or dirt. Clean or replace when dirty or damaged.
- Check sensor cabling with regular intervals for damages and wear as this may cause improper functioning. Replace when necessary.
- Check presence of sufficient grease on the transducer pipe contact side in case of acoustic signal failure.
- Check the sensor rail sliding area regularly for dirt or other pollution or excess coupling fat, that may cause improper functioning.
- Excess of coupling fat may be removed from the sensor rails and transducers with a dry piece of cloth. Coupling fat on the converter housing may be removed using soapy water.

Specific for converters:**WARNING!**

Be careful moving the handle of the converter, as your fingers may get stuck between the handle and the housing of the converter. This may cause injury.

**CAUTION!**

- In order to comply with the EMC directive 2004/108/EC, I/O cables that provide a galvanic connection to the should have a maximum total length of 3 meter.
- When not used, put the connector covers of the connectors on the bottom side of the converter in place. This to prevent improper functioning caused by dust/dirt.
- When the sensor cables are connected while the converter is positioned on a flat surface, turn the handle fully backwards (towards the housing) in order to prevent excess stress on the sensor cables.
- In order to keep the battery at an optimum condition the battery should be charged at least once every 6 months.
- If the main battery is empty for a period longer than one year, the backup battery of the real time clock may run empty.
- The protection degree of the battery charger / mains adapter is IP 40 / NEMA 1. It should be protected against moisture entering.
- To prevent damage due to vibrations, do not firmly attach the converter to or place it on top of a vibrating object.

3.2 Step 1: Find location and determine data

**CAUTION!**

Do not start to mount the rails yet! Step 1 is only meant to find a suitable location for a measurement. The installation itself will be done in Step 3.

Inlet, outlet and recommended mounting area

To perform an accurate flow measurement preferably mount the sensor rail at least 10 DN downstream of a flow disturbance like elbows, valves, headers or pumps. Follow the given installation recommendations.

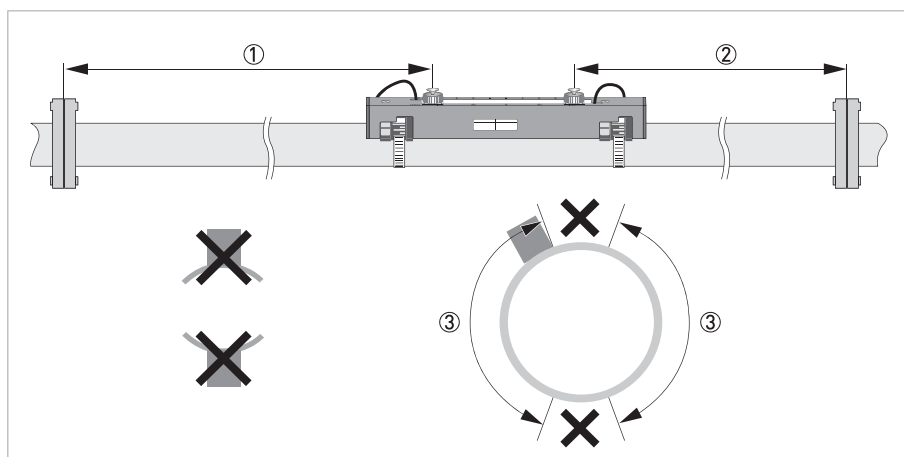

Figure 3-1: Inlet, outlet and recommended mounting area

- ① Min. 10 DN
- ② Min. 5 DN
- ③ Recommended installation location (120°)



CAUTION!

Make sure that the rail is not mounted at the highest point (risk for air bubbles) or at the lowest point (risk for particles) of the pipe.

Long horizontal pipes

- Install on slightly ascending pipe section.
- If not possible, make sure that the flow velocity is high enough to prevent air, gas or vapor to collect in upper part.
- In partially filled pipes, the clamp-on flowmeter will report incorrect flow rates, or not measure.

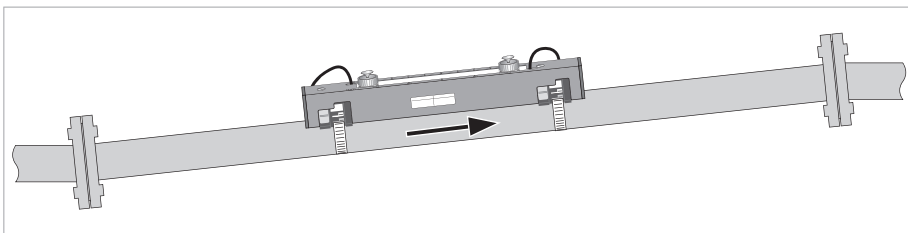

Figure 3-2: Long horizontal pipes

Vertical pipelines



CAUTION!

Make sure that the pipe is fully filled at all times.



INFORMATION!

Both ascending and descending flow directions are measurable.

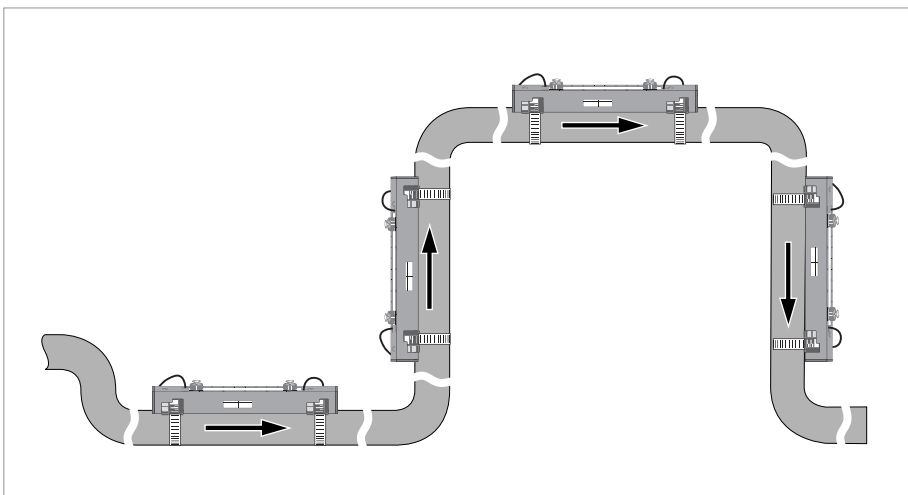

Figure 3-3: Mounting on vertical pipelines is possible

Open feed or discharge

Install meter on a lowered section of the pipe to make sure that there is a full pipe condition.

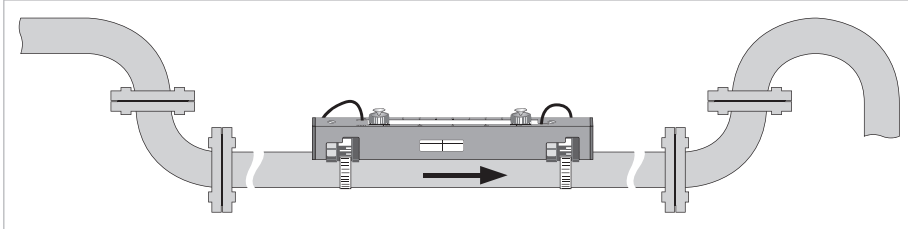

Figure 3-4: Open feed or discharge

Down going pipeline over 5 m / 16 ft length

Install an air vent downstream of the flowmeter to prevent vacuum. It may cause gases to come out of solution (cavitate) that prevent a proper measurement.

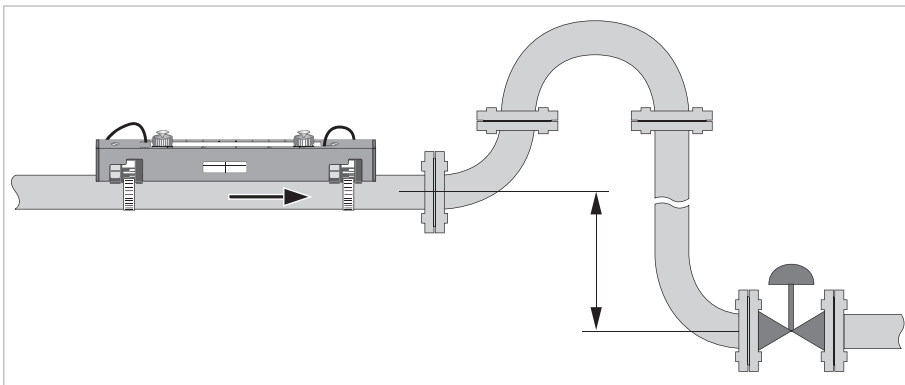

Figure 3-5: Down going pipeline over 5 m / 16 ft length

Position of control valve

Always install control valves downstream of the flowmeter in order to avoid cavitation or distortion of the flow profile.

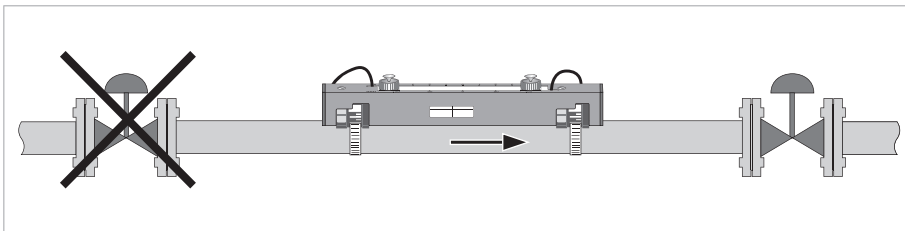

Figure 3-6: Position of control valve

Position of pump



CAUTION!

Never install the flowmeter at the suction side of a pump in order to avoid cavitation or flashing in the flowmeter.

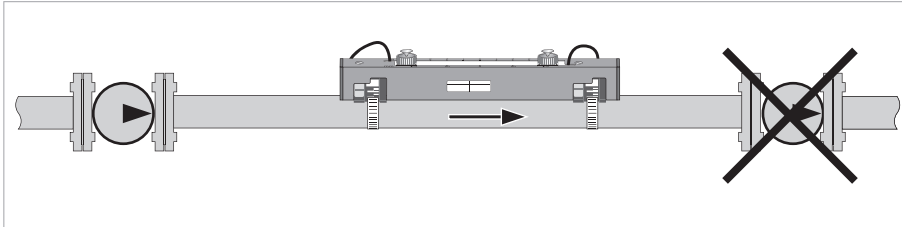

Figure 3-7: Position of pump

Determine data and dimensions of pipe



CAUTION!

The next data must be available before proceeding with Step 2.

- Use the supplied tape measure to determine the outside diameter of the pipe.
- Determine the pipe wall thickness. A pipe wall thickness gauge or pipe tables can be used for this.
- Find out what the material of the pipe is.
- If the pipe has a liner, find out the liner material and the thickness of the liner.

3.3 Step 2: Initialise the TWS 2000 converter



Figure 3-8: Keys TWS 2000

- ① TFT Display
- ② Navigation keys
- ③ Quick access keys
- ④ Text and numerical keypad
- ⑤ On / off button



- Turn on the converter by pressing the on / off button for one second. Wait until the menu appears, this will take approximately 30 seconds.



INFORMATION!
FIRST TIME USE:

When the TWS 2000 converter is started for the first time, the startup menu will be shown. In this menu, set the language, time and date.

To show the menu again at the next startup, select "Settings and information ▶ Device ▶ Start-up sequence? ▶ Yes".

First time use

Menu	
Language	English
Time and date	
Units	
Continue	
13-04-2010 14:11:09 13 MB free	

First time use, program the units in the converter

If you use the converter for the first time, it will prompt you for the unit setting automatically. Otherwise go to menu number 2.4.1 ("Measurement ▶ Setup ▶ Units"). Choose in each line the required unit with the buttons as shown in the next table.

Navigate through the menu

◀	Back	Back one page
^	Up	Up one line
∨	Down	Down one line
▶	Forward	Enter item to edit or to select it

When editing, only the Back and Forward buttons are functional:

◀	Back	Delete previous character or leave item unchanged when at position one
▶	Forward	Move cursor right, accept item when at last position

REGULAR USE:

If the device has been used before, the screen will look like:

Menu
Installation ▶ Measurement View logged data File Management Settings and information
13-04-2010 14:11:09 13 MB free

Program the converter



CAUTION!

Normally, all settings are saved in a site file. To load the default values, load the default site file via "Measurement > Load file".

If needed you can recover the factory settings for the site file via "Settings and Information > Load factory settings". Previous saved site files are kept during this process.



- Select "Installation" from the main menu.

Menu
Installation ▶ Measurement View logged data File management Settings & information
13-04-2010 14:11:09 13 MB free

The next screen is shown:

1.1
1 pipe / 1 path ▶ 1 pipe / 2 path 2 pipes
13-04-2010 14:11:09 13 MB free

See the next figure for an explanation of the options:

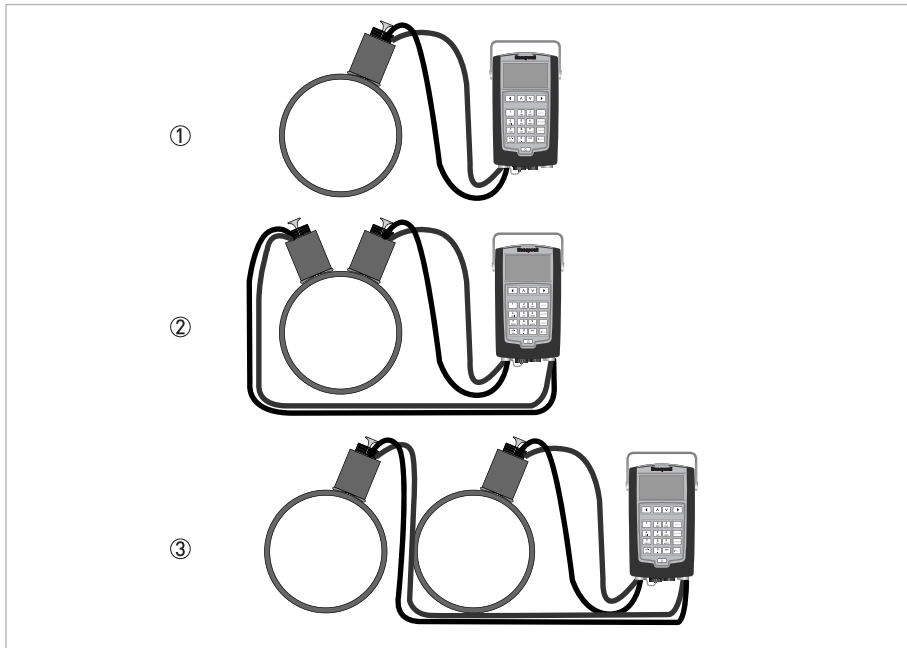

Figure 3-9: System configuration possibilities

- ① 1 pipe / 1 path
- ② 1 pipe / 2 path
- ③ 2 pipes



- Choose the desired configuration.
- In the next screen, fill in the data that was found in Step 1.

1.2	
Pipe tag	Pipe1
Outer diameter	100.00 mm
Material	Carbon steel
Wall thickness	5.00 mm
Liner material	Epoxy
Liner thickness	0.50 mm
< Previous Next >	
13-04-2010 14:11:09	13 MB free

Pipe tag	Enter a name for the pipe
Press again "▶" and "▼".	
Outer diameter	Use the outside diameter
Material	Choose the right material
Wall thickness	Fill in the pipe wall thickness
Liner material	Select whether there is a liner or not
Liner thickness	Fill in the liner thickness
	The liner thickness will only be shown if a liner material is chosen.

Choose next



CAUTION!

Inaccurate input of the outside diameter will affect the accuracy of the measured flow rate.



INFORMATION!

In case of a two pipe configuration, the converter will ask if the data entered for pipe 1 has to be used for pipe 2 too.

Menu 1.2 and 1.3 are shown again to enter the data for the second pipe.

1.3	
Fluid VoS Fluid Viscosity < Previous Next > ▶	Water 1485.0 m/s 1 mm ² /s
13-04-2010 14:11:09 13 MB free	

- Fluid Select the correct fluid from the table.
- VoS Fluid Velocity of Sound of the selected fluid. Only change it if highly accurate values are available, for instance temperature compensated.
- Viscosity Only change it if the viscosity is well known.
- Choose next

An advise is given in the next menu:



CAUTION!

Find the calibration numbers that are noted on the labels on the cable of each transducer. Make sure that both transducers have the same calibration number as shown by the converter.

1.7	
Transducer set Calibration number Number of traverses < Previous Next > ▶	Ta 522505050 2
13-04-2010 14:11:09 13 MB free	



CAUTION!

Normally, do not change the settings in this menu.



INFORMATION!

In case of a two sensor configuration, this loop will be shown twice. After installing the first transducer the converter will produce a second advice for the second installation.

- Transducer set Select the value that is on the label on the transducer cable.

Note: A maximum of three transducer sets can be programmed in the converter, called Ta, Tb or Tc.

Calibration number Compare the calibration number with the number on the transducer cable. If needed, select a different transducer set to change the calibration number.

Number of traverses 1 traverse = Z mode
 2 traverses = V mode
 4 traverses = W mode

See figure below for an explanation of the number of traverses.

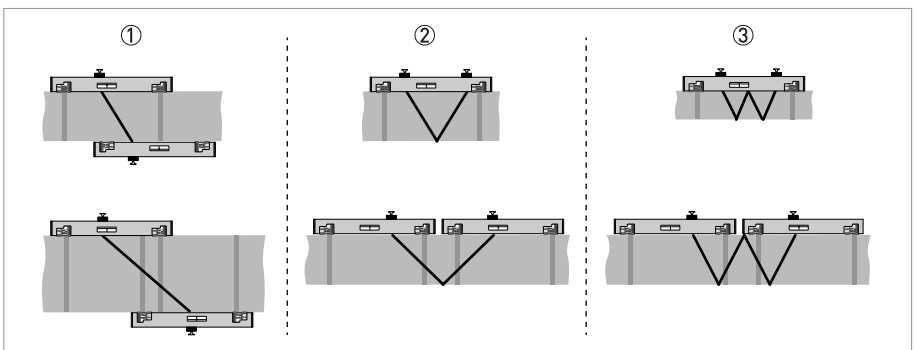



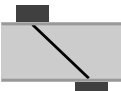

Figure 3-10: Number of traverses

- ① 1 traverse (Z mode)
- ② 2 traverses (V mode)
- ③ 4 traverses (W mode)

The best suitable sensor is automatically selected from the available sensor types in the converter and the appropriate number of traverses is indicated. If none of the sensors is suitable, the converter will show "Transducer set : None".

Pipe	Available sensor	Traverse mode	
DN15...150	Small 2 MHz, 1 rail		
DN50...250	Medium 1 MHz, 1 rail		
DN200...750	Medium 1 MHz, 2 rails		
DN400...1500	Medium 1 MHz, 2 rails		



CAUTION!
 Normally, install the sensors as advised. If the quality of the pipe walls is poor and / or in case of scaling inside the pipes, try to decrease the amount of traverses or (if possible) use a medium sensor instead of a small sensor.



- Press Next to go to the next menu:

1.8		
Advised sensor position		
34.30 mm		
Signal quality		
		0%
< Previous Next > ▶		
13-04-2010 14:11:09 13 MB free		

Advised distance [mm]	Number of rails needed
< 190	1
≥ 190	2



INFORMATION!

The maximum distance that can be covered with 1 rail is 195 mm.
The minimum distance for two rails is 180 mm.



INFORMATION!

On request it is possible to use the large rail of the VersaFlow Sonic 1000 / TWS 9000 with 0,5 MHz transducers. Using this you can measure up to DN4000.

3.4 Step 3: Mount the sensor rails

Before mounting the rails, determine the colors on the connectors of the transducers. Make sure that the blue transducer is upstream and the green transducer is downstream.

Installation with metal straps (DN15...250)

Put the metal straps around the pipe. Put the sensor rail(s) on the pipe including the transducers with fixed cables.

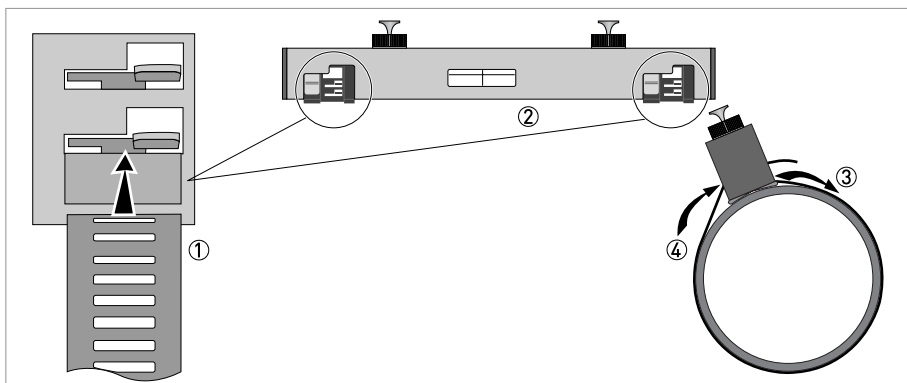

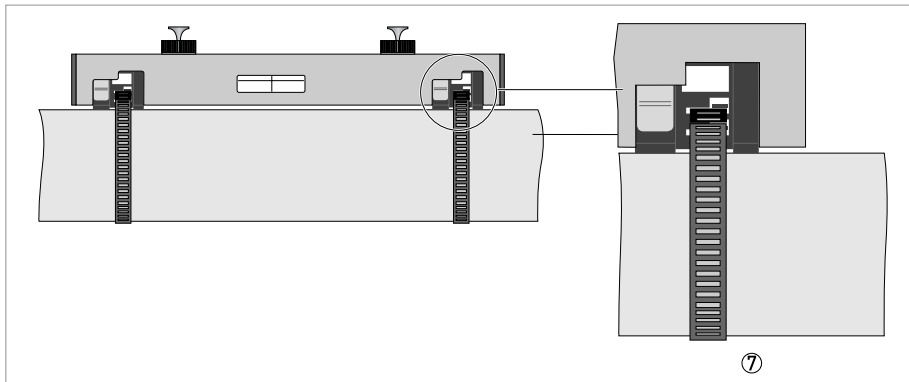

- ① Insert straps in the lower opening.
- ② Repeat the same for the other strap.
- ③ Pull the straps around the pipe.
- ④ Insert the straps in the upper opening.
- ⑤ Pull the straps tight.
- ⑥ Use an allen key nr 5 (or a big screwdriver) to fixate the rails.

Installation with textile straps (> DN250)

For pipe diameters above DN250, the textile straps must be used.

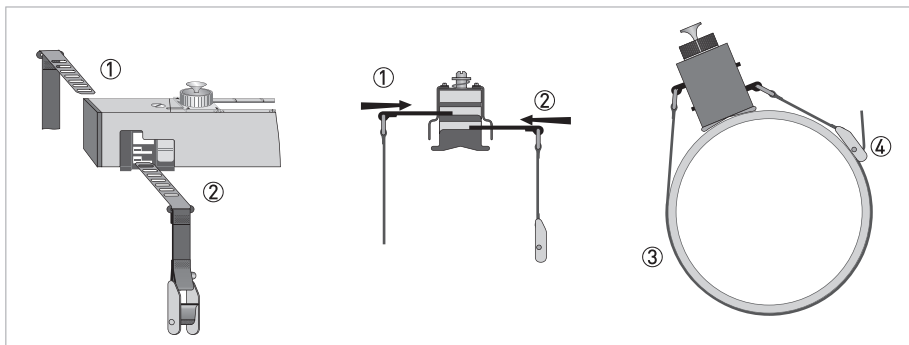

- ① Insert the long strap in the upper opening.
- ② Insert the short strap in the lower opening at the other side of the rail.
- ③ Pull the strap around the pipe.
- ④ Fix the strap, as indicated below.

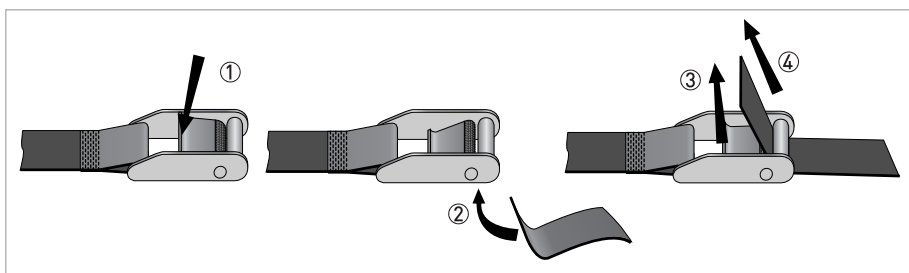

- ① Push lever to create a opening.
- ② Insert the textile strap as indicated.
- ③ Release lever.
- ④ Pull strap tight.
- ⑤ Use an allan key nr 5 (or a big screwdriver) to fixate the rails.

3.4.1 2 or 4 traverses with 1 rail

Applicable diameters with one rail:

Number of traverses	Diameter range
2	DN15...250
4	DN15...150

Put the first transducer at position "0". Put the other transducer at the advised distance, shown on the screen in Step 2. See the figures below.

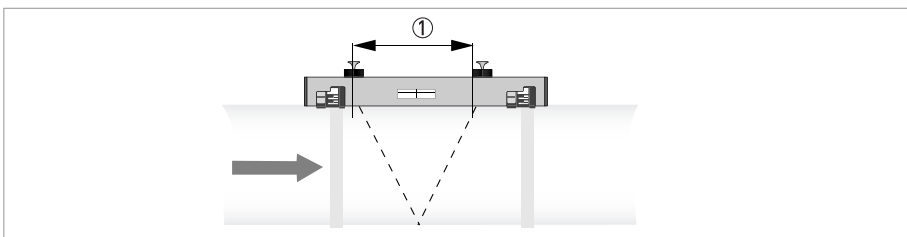
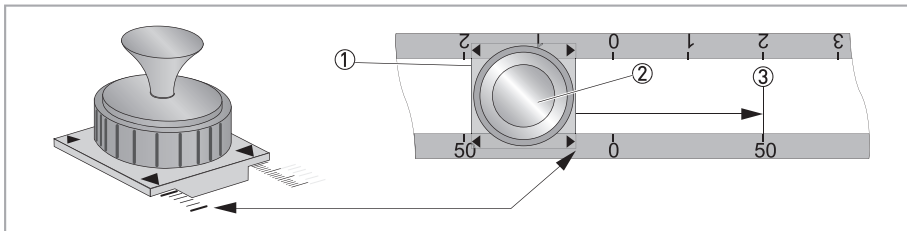

Figure 3-11: Advised distance with one rail

① Advised distance is measured from center first transducer to indicator at second transducer.



- Unlock the transducer by turning the locking knob ② counter clockwise.
- Slide the transducer ① to the new position ③.
- Lock the transducer by turning the locking knob ② clockwise.

3.4.2 2 traverses with 2 rails

Applicable diameters with two rails:

Number of traverses	Diameter range
2	DN200...750

**INFORMATION!**

The two rails must be installed in a straight line.

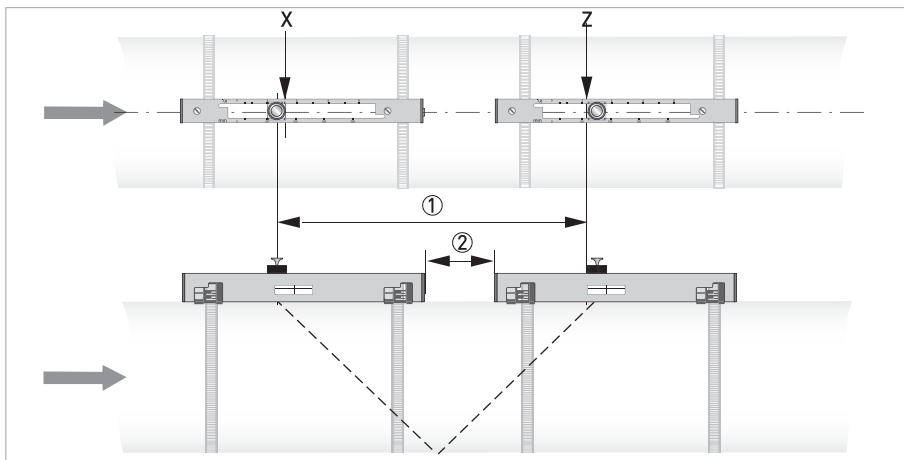

Figure 3-12: Mounting 2 rails in V-mode (2 traverses)

- ① Advised distance
- ② Distance between 2 rails



- Mount the first rail on the pipe. Make sure that you mount the rail in line with the pipe!
- Position the left transducer in any position X (see next section).
- Mount the second rail (align it with the first rail) at a distance ② to arrange that the transducer in the second rail is within the range it can be moved.
- The advised distance ① is defined from the **center** of the left transducer to the **left** side of the right transducer. Put the second transducer at position $Z = \text{advised distance } ① + X - \text{distance } ② - 415 \text{ mm} / 16.3''$.

3.4.3 1 traverse with 2 rails (DN400...1500)

Applicable diameters with two rails:

Number of traverses	Diameter range
1	DN400...1500



- Measure the outer diameter of the pipe with the tape measure.
- Calculate the half of the outer diameter.
- Start at the left side of the rail and locate the opposite side using the calculated half of the outer diameter.
- Put a mark at this position.
- Repeat this at the right side of the rail.
- Draw a line between the two markings.
- Mount the DOWN rail in such a way that the transducer is at the marked location.

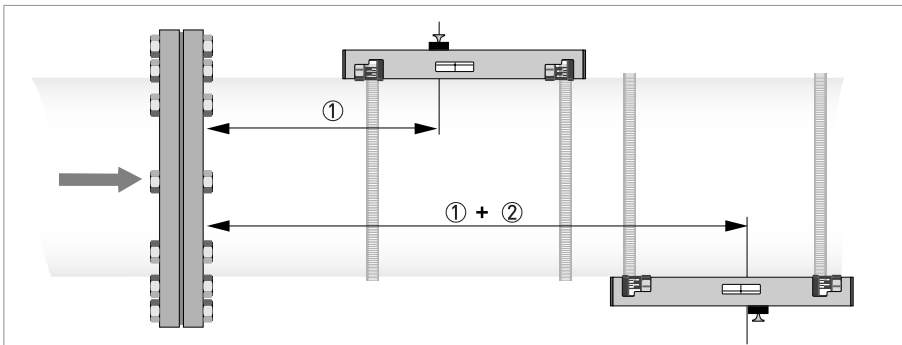
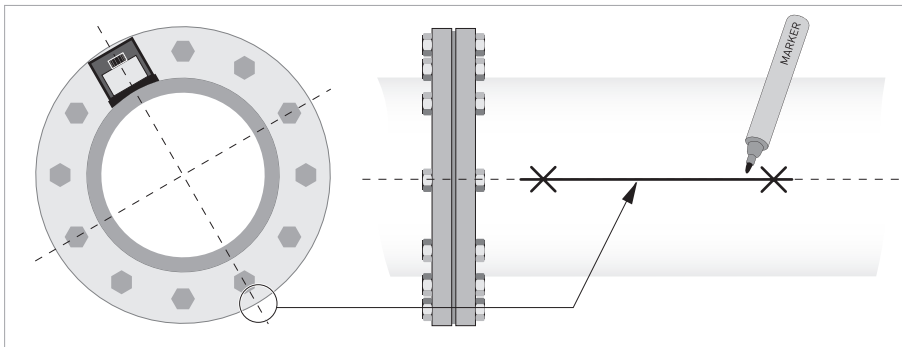

Figure 3-13: Mounting second rail in Z mode (1 traverse) using a reference point

- ① Measure the distance between the transducer of the UP rail and the reference point.
- ② Add the advised distance to determine the position of the second transducer.

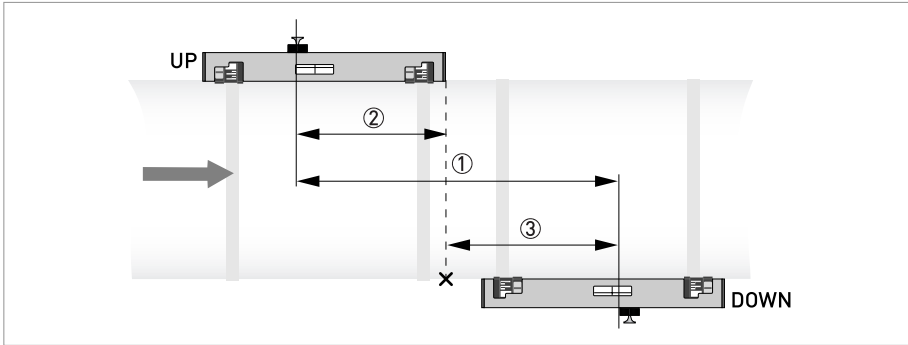

Figure 3-14: Mounting second rail in Z mode (1 traverse) without using a reference point

① Advised distance ① = ② + ③

3.4.4 Apply coupling grease

Push the buttons of the fixing units to unlock and tilt the rail. Then put some coupling grease on the transducers and put the rail back by clicking.

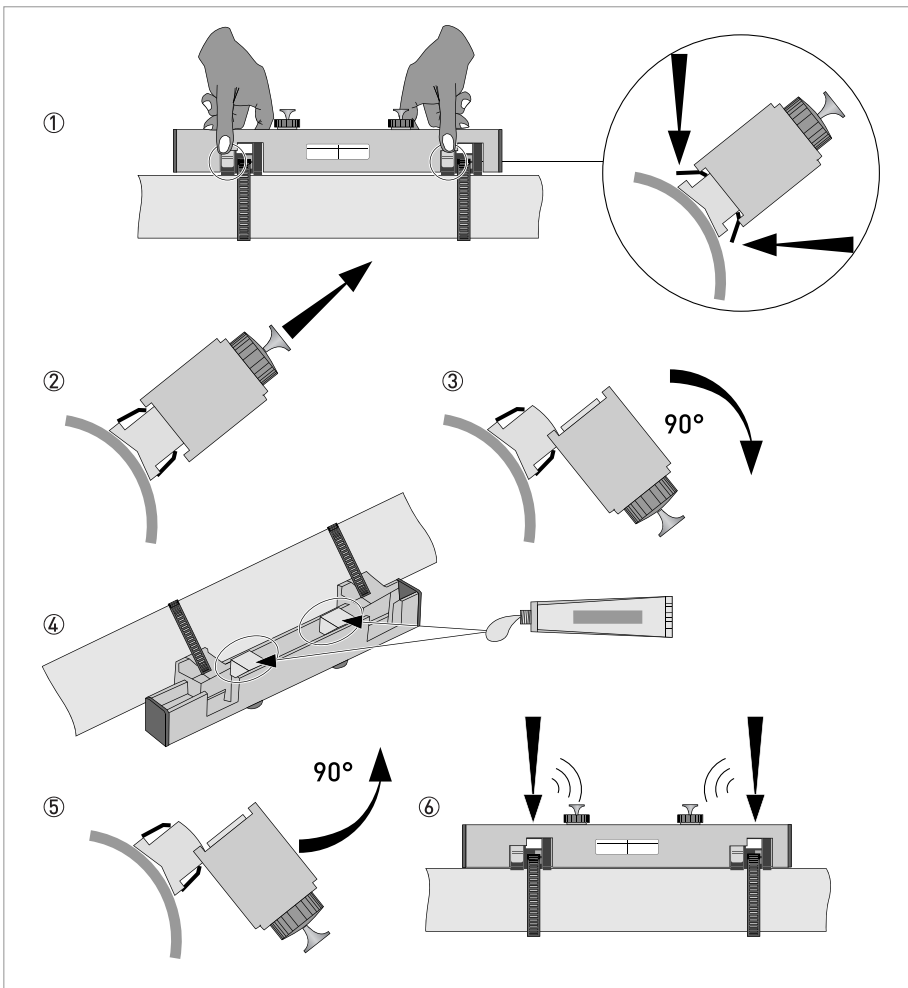

Figure 3-15: Greasing transducers

3.4.5 Connect the sensor cable

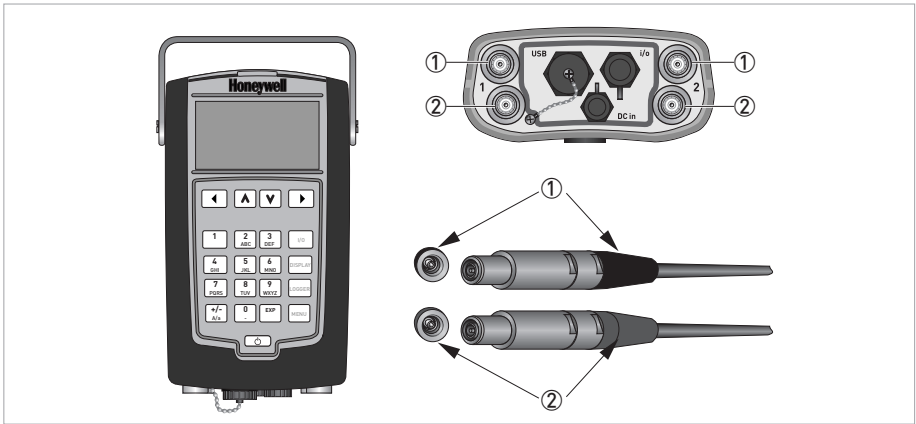
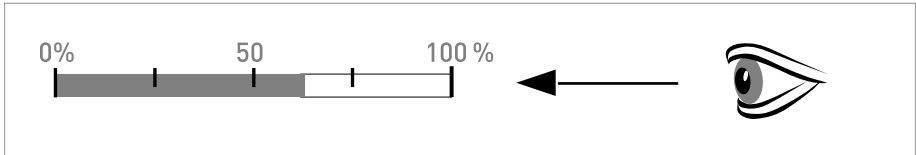

Figure 3-16: Connecting signal cables
 ① Connector for "UP" transducer (blue)
 ② Connector for "DOWN" transducer (green)



INFORMATION!
 After mounting the transducers in the proper position, it takes up to 60 seconds to find a signal.



INFORMATION!
 The signal strength is given and can be qualified as shown:

Signal strength	Qualification
> 75%	High signal
50...75%	Fairly high signal
10...50%	Low signal
< 10%	Bad or no signal Check settings in menu, change transducer distance until there is at least a low signal.

1.8	
Advised sensor position	
52.18 mm	
Signal quality	
	78%
< Previous Next > ▶	
13-04-2010 14:11:09 13 MB free	



- Proceed with the optimization loop in step 4.

3.5 Step 4: Optimization loop



CAUTION!

If the actual sensor position is not entered accurately, the sound velocity can not be calculated correctly and optimization of the sensor position will fail.



- Press "▶".

1.10	
Advised sensor position	66.05 mm
Actual sensor position	66.05 mm
< Previous Next > ▶	
13-04-2010 14:11:09 13 MB free	



- Make sure that the transducers are mounted at the advised distance.
- Press Next ▶.

1.12	
Volume flow	50 m ³ /h
Velocity of sound	1481.3 m/s
Signal quality	69%
Optimize position ▶	
< Previous Next >	
13-04-2010 14:11:09 13 MB free	



- Press Optimize position ▶.



INFORMATION!

The optimization loop uses the measured VoS and compares it to the entered VoS.



- The optimization loop will give a new advise on the transducer distance. Slide the transducers to the new position. Repeat this loop until the advised distance does not change more than 1% or 1 mm.

- In menu 1.12, press Next ▶.

1.19	
Sensor 1 status Signal quality	Installed 80 %
< Previous Next > ▶	
13-04-2010 14:11:09 13 MB free	



- Press Next ▶.

1.20	
Site name ▶	test
Cancel Skip saving Save site file	
13-04-2010 14:11:09 13 MB free	



INFORMATION!

You can save the settings in a site file, so they can be used again later when measuring at the same site (location).



- Enter a file name.
- Select Save site file ▶.

Measurement	
Site name	test
Display measurement ▶ Load site Save current site Setup	
13-04-2010 14:11:09 13 MB free	



INFORMATION!

The device is now ready to measure.

3.6 Step 5: start flow measurement

Press "▶" on the converter. The converter checks the received signal and initiates the flow measurement mode.

The display will show the actual flow now.

3.7 Error messages

Error code	Group message	Error message	Description	Error handling
F	error in device		no measurement possible, measured values are not valid	repair or replace device and/or CPU; contact manufacturer service center
F	application error		no measurement possible, but device ok	check parameter settings / power off - wait 5 seconds - power on device
S	out of specification		unreliable measurement	maintenance required, check flowprofile
C	check in progress		test function is active, device is stand-by	wait until finished
I	information		no direct impact on measurements	no action needed
F		IO 1 (or IO 2)	error or failure of IO Module 1 (or 2)	try to load settings (menu C8.6.3); if error does not disappear, replace electronics unit
F		parameter	error or failure of data manager, parameter or hardware error	try to load settings (menu C8.6.3); if error does not disappear, replace electronics unit
F		configuration	incorrect configuration or no confirmation	confirm change of module; if configuration is unchanged, replace electronics unit
F		display	error of failure of display unit, parameter or hardware error	defect; replace electronics units
F		current output A (or B, C)	error or failure of the current output A (or B, C), parameter or hardware error	defect; replace electronics units
F		software user interface		defect; replace electronics units
F		hardware settings	detected hardware and set hardware settings do not match	follow display instructions
F		hardware detection	hardware can not be detected	defect; replace electronics units
F		RAM/ROM error IO 1 (or IO 2)		defect; replace electronics units
F		communication dsp-up	no communication between DSP and microprocessor PCB	contact manufacturer service center
F		front end	malfunctioning of front end PCB	contact manufacturer service center
F		uproc	malfunctioning of microcontroller PCB	contact manufacturer service center
F		dsp	malfunctioning of DSP	contact manufacturer service center
F		empty pipe	signal lost at two paths	check process conditions
F		flow > max 1	max volume flow exceeded for pipe 1	check parameter in menu C1.7.1
F		flow > max 2	max volume flow exceeded for pipe 2	check parameter in menu C1.7.1
F		open circuit A (or B, C)	current on current output A (or B, C) too low	check cable or reduce resistance (< 1000 Ohm)
F		over range A (or B, C)	current on current output A (or B, C) is limited by parameter setting	extend upper or lower limit for current output in menu C5.2.8
F		over range A (or B, D)	pulse on frequency output A (or B, D) is limited by parameter setting	extend upper or lower limit for frequency output in menu C5.3.7
F		active settings	error during CRC check (Cyclic Redundancy Check) of the active settings	load settings; factory setting, back up 1 or back up 2

F		factory settings	error during CRC check of factory settings	
F		back up 1 (or 2) settings	error during CRC check of back up 1 (or 2) settings	
F		signal lost path 1	signal lost at path 1	check signal cable / check for pipe obstructions
F		signal lost path 2	signal lost at path 2	check signal cable / check for pipe obstructions
F		pipe/sens1 param.	unrealistic parameter settings for pipe in combination with path 1	check parameters in menu X6
F		pipe/sens2 param.	unrealistic parameter settings for pipe in combination with path 2	check parameters in menu X6
S		unreliable 1	unreliable measurement at pipe 1	check process conditions for gas bubbles, solids
S		unreliable 2	unreliable measurement at pipe 2	check process conditions for gas bubbles, solids
S		zero converter	invalid value at power up	power off - wait 5 seconds - power on device
S		overflow counter 1 (or 2, 3)	counter is overflowing and will start again at zero	no action needed
S		backplane invalid	error during CRC check of backplane	restore data records on backplane
I		counter 1 (or 2, 3) stopped	counter has stopped	reset counter in menu C8.9.1 (or C8.9.2, C8.9.3)
I		control input A (or B) active	information only	no action needed
I		over range display 1 (or 2)	1 st row on 1 st (or 2 nd) measurement page is limited by parameter setting	extend upper or lower limit for limitation in menu C8.3.4
I		backplane sensor	incompatible data sensor on backplane	
I		backplane settings	incompatible data on backplane	
I		backplane difference	different data on backplane and display	
I		optical interface	optical interface is operational, local display can not be used	
I		softw sync error	incompatible DSP and microprocessor software	

The combination of the measured flow rate and a temperature difference over a device can be used to determine the amount of energy used by that device. The temperature difference can either be programmed manually in the converter or be measured with temperature transmitters, connected to an optional I/O box. In this case, the temperature difference is determined by measuring the temperature before and after the heat/cold producer/consumer.

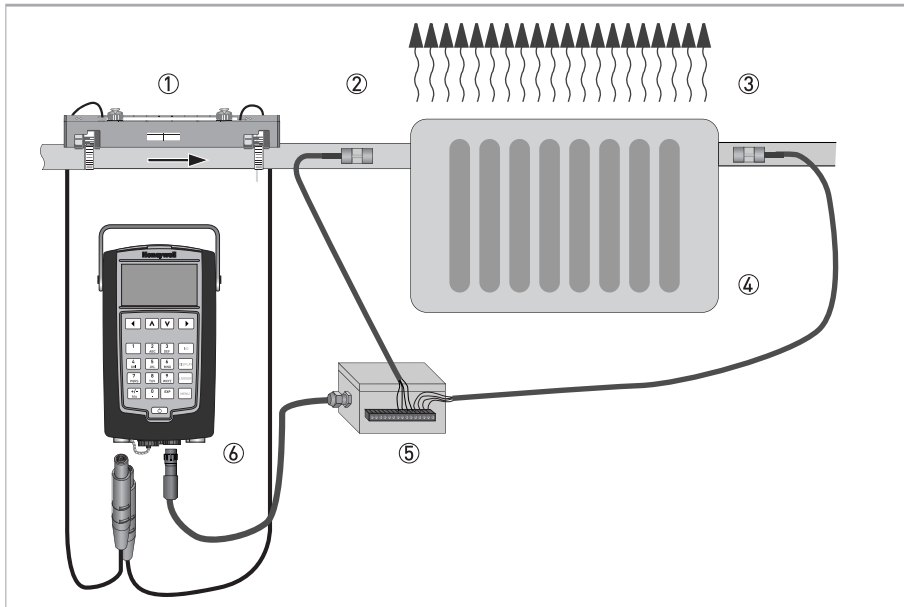

Figure 4-1: Energy measurement of heat user

- ① Mounted rail (in any measuring mode)
- ② PT 100 temperature sensor, before the heat/cold producer/consumer
- ③ PT 100 temperature sensor, after the heat/cold producer/consumer
- ④ Radiator
- ⑤ Optional I/O box with temperature option
- ⑥ Converter



INFORMATION!

Please find more detailed information in the next sections to set up an energy measurement.

4.1 Preparation of energy measurement



- ① Install a flow measurement as described in the previous chapter. Make sure that the rail and converter are installed close to the location of the place where the temperature sensors must be installed, because of the fixed (limited) length of the sensor cables.
- ② Check if temperature transmitters are already available on site.

Transmitters are already available on site:

Make sure that the **basis I/O box** is used. Connect the temperature transmitters to the 4...20 mA current input of basic I/O, which is connected to the converter.

Transmitters are not available on site:

Make sure that the **Extended I/O box** is used. In this version, the temperature transmitters are included. Optionally, clamp-on PT 100 temperature sensors can be delivered, with a temperature range of 0...120°C / 32...248°F, including two meter cable and suitable for pipes up to DN300.

4.2 Mechanical installation

Mounting of temperature sensors

The delivered PT 100 sensors are clamp-on elements. Clamp them on the pipe with the hose clamp.



INFORMATION!

Mount the temperature sensors close to the rail for flow measurement. All cables have a fixed length!

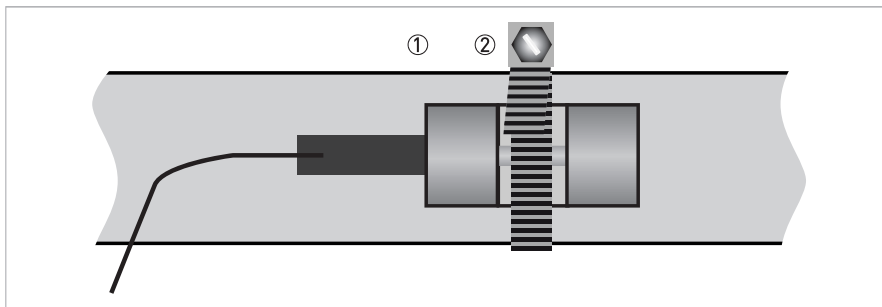

Figure 4-2: Mounting PT 100 with hose clamp

- ① PT 100 temperature transmitter
- ② Hose clamp

If the temperature sensors on the pipe have temperature transmitters 4...20 mA it is possible to make use of the standard I/O box.



- Connect the PT 100 elements to the I/O box according to the sticker on the I/O box.

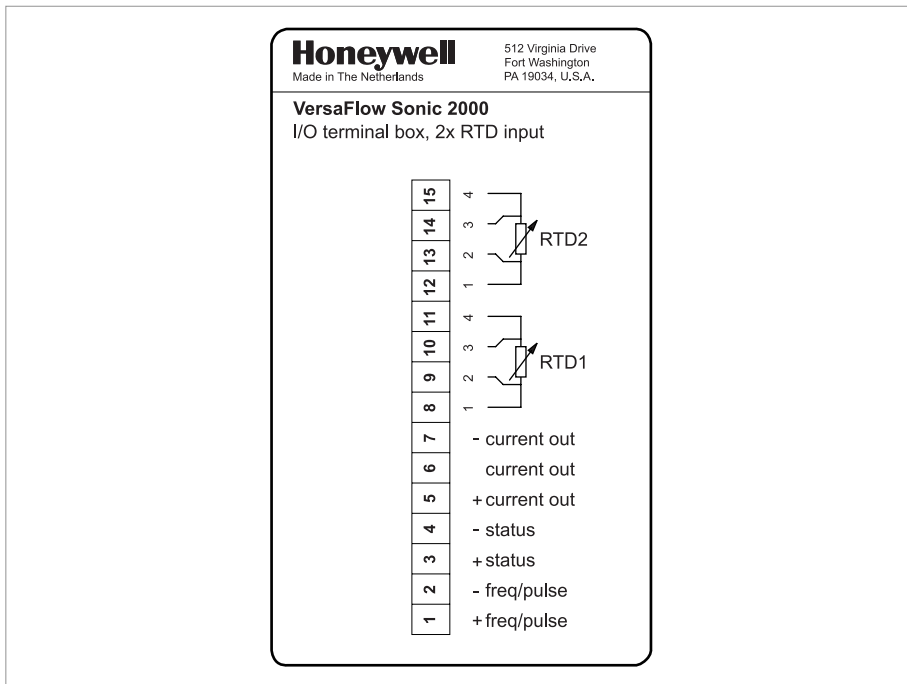

Figure 4-3: Extended I/O box with 2 temperature transmitters included for PT 100 sensors.

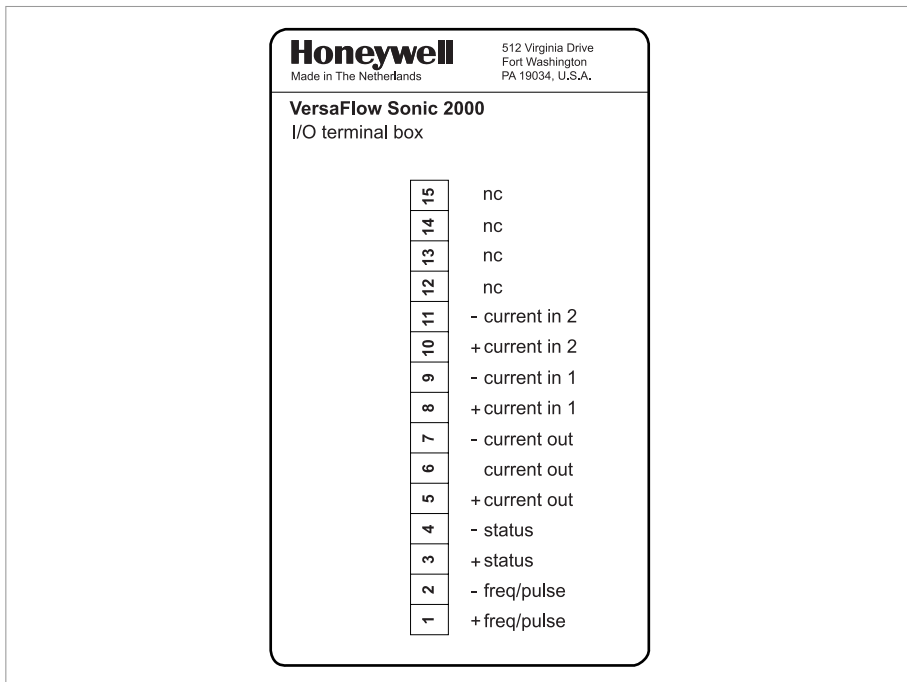

Figure 4-4: Basic I/O box for 4...20 mA temperature transmitters



- Plug the connector ② of the I/O box ③ in the connector ① of the converter, as shown in the figure below.

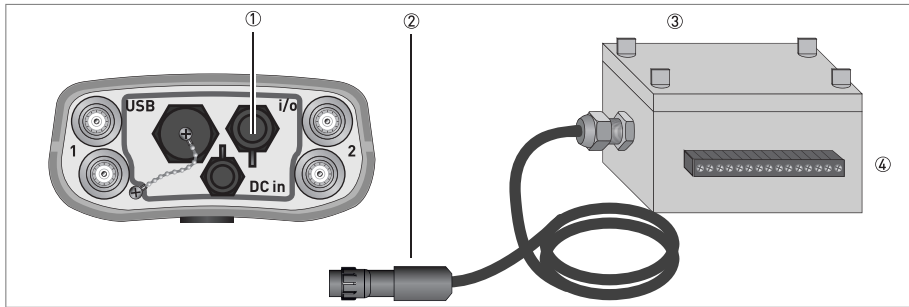

Figure 4-5: I/O box

- ① I/O connector on converter
- ② Connector of I/O box
- ③ I/O box with screw terminals for 1 mm² wiring
- ④ Screw terminal pin 1...15

4.3 Program the converter

Three settings must be programmed in order to measure the amount of energy.

4.3.1 Program the I/O input



- Go to menu nr. 2.4.5 via "Measurement ▶ Setup ▶ I/O"

2.4.5
Current output Current inputs ▶ Status output / limit switch Frequency / pulse output Simulation
13-04-2010 14:11:09 13 MB free

If the recommended Honeywell energy set is used, the standard settings are correct. The temperature range is 4 mA = 0°C / 32°F and 20 mA = 120°C / 248°F:



INFORMATION!

On the converter, you must scroll down in the menu to see all settings.

2.4.5.2	
Function ▶	On
Extended range A 0%	3.6 mA
Extended range A 100%	21 mA
Extended range B 0%	3.6 mA
Extended range B 100%	21 mA
Temperature range A 0%	0.0 °C
Temperature range A 100%	120.0 °C
Temperature range B 0%	0.0 °C
Temperature range B 100%	120.0 °C
Time constant A	1 s
Time constant B	1 s
4 mA trimming A	4 mA
20 mA trimming A	20 mA
4 mA trimming B	4 mA
20 mA trimming B	20 mA
13-04-2010 14:11:09 13 MB free	

If another energy set is used, teach in the required values.



INFORMATION!

The "Extended range A/B 0% and 100%" are meant for an alarm function. If a value is measured that is lower than the "Extended range A/B 0%" value or higher than the "Extended range A/B 100%" value, an event will be logged in the event logger.

4.3.2 Program the process input



- Go to menu 2.4.2.3.1 via "Measurement ▶ Setup ▶ Process input ▶ Heat ▶ Function off ▶"

2.4.2.3.1	
Heating ▶	
Cooling	
Off	
13-04-2010 14:11:09 13 MB free	



- Choose "Heating" or "Cooling" to activate energy measurement.

2.4.2.3	
Function	Heating
Temperature input ▶	Terminal A at supply
Sensor location	Supply
Fluid	Water
13-04-2010 14:11:09 13 MB free	



- Choose in "Temperature input ▶" which sensor is located at the supply side of the process.



INFORMATION!

In case the function is "Heating", the temperature at the "supply" side is the highest.
 In case the function is "Cooling", the temperature at the "supply" side is the lowest.

Manually entering the temperature values



- If there are no temperature sensors available for connecting, set the "Temperature input" to "Manual".

2.4.2.3	
Function Temperature input ▶	Heating Manual
Supply temperature	80.0 °C
Return temperature	120.0 °C
Sensor location	Supply
Fluid	Water
13-04-2010 14:11:09 13 MB free	



- Set the location of the flow sensor (supply or return side of the installation) in order to calculate the correct specific heat of the liquid.
- Check whether the shown fluid is correct.



INFORMATION!

The type of fluid is set in the flow sensor installation wizard. In case the fluid is set to water-glycol mixture in the flow sensor installation wizard the concentration of glycol in water can be set in the heating/cooling setup menu.

2.4.2.3	
Function Temperature input ▶	Heating Terminal A at supply
Sensor location	Supply
Fluid	Water
13-04-2010 14:11:09 13 MB free	

4.3.3 Program the counters



- Go to menu 2.4.6 and select a counter for counting energy. Use counter 3 or 4 for energy measurements as they have a higher limit.

2.4.6.1	
Function of counter ▶	+ counter
Measurement	Power
Low flow cutoff threshold	0.000 kW
Low flow cutoff hysteresis	0.000 kW
Preset value	0 kJ
Reset counter	
Set counter	
Stop counter	
13-04-2010 14:11:09 13 MB free	



- At the "Function of counter", select "Sum" for counting both positive and negative energy flows.
- Select "+ counter" for only counting positive energy flows.
- Select "- counter" for only counting negative energy flows.
- At the "Measurement" option, select "Power". The energy value counter unit is kJ.

4.4 Start measurement

The following parameters are available when heating or cooling measurement is switched on:

- Temperature A/B
- Temperature difference
- Thermal power (power)
- Thermal energy (totalized power)

To setup the display to view those parameters please refer to the display setup paragraph.

The unit for energy measurement can standard be set to Joule (kilo, mega, giga), Wh (kilo, mega) or BTU (kilo, million (MM)). In case any other unit is required the free unit can be used. To setup the free unit go to "Measurement ▶ Setup ▶ Units ▶". Select the power or energy parameter, then select "Free unit". Enter the text for the unit, then the factor for the unit entered.

The factor for energy is the amount of Joules in the free unit. The factor for power is the amount of Watt's in the free unit.

Underneath you find a table with factors for alternative energy units.

Unit of power	Description	W factor (amount of Watt in unit)
Ton (refrigeration)	A ton of reffridgeration is defined as the cooling power to melt one short ton (2000 pounds or 907 kg) of ice in a 24 hour period. This is equal to 12000 BTU per hour or 3527 W.	3527
kilo calorie per second	Power required to heat 1 kg of water with 1 degree Celsius in 1 second.	4187

Unit of energy	Description	J factor (amount of Joule in unit)
Ton-hour (refrigeration)	A ton-hour of reffridgeration is defined as the energy to melt one short ton (2000 pounds or 907 kg) of ice.	12660000
kilo calorie per second	Amount of heat required to increase 1 kg of water with 1 degree Celsius.	4187
Therm	Equal to 100000 BTU	105506000

5.1 Safety instructions



DANGER!

All work on the electrical connections may only be carried out with the power disconnected. Take note of the voltage data on the nameplate!



DANGER!

Observe the national regulations for electrical installations!



WARNING!

Observe without fail the local occupational health and safety regulations. Any work done on the electrical components of the measuring device may only be carried out by properly trained specialists.



INFORMATION!

Look at the device nameplate to ensure that the device is delivered according to your order. Check for the correct supply voltage printed on the nameplate.

5.2 Location of connectors at the converter

All connectors are located at the bottom side of the converter.



5.3 Power supply

**WARNING!**

Only use the supplied AC charger to charge the battery of the converter!

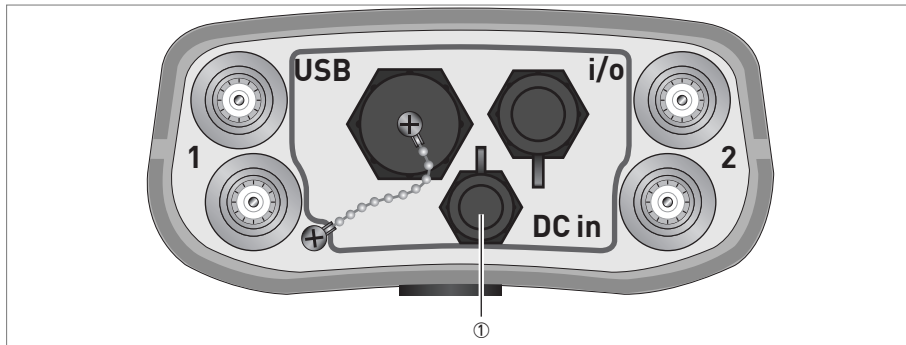

Plug in the connector of the supplied charger at the connector ①. Then insert the main power connector into your mains outlet.

**CAUTION!**

The battery status indicator will be accurate after an initial full discharge directly followed by a full charge of the battery.

5.4 Signal cable

**CAUTION!**

Find the calibration numbers that are noted on the labels on the cable of each transducer. Make sure that both transducers have the same calibration number as shown by the converter.

**INFORMATION!**

The signal cables are prefixed to the transducers in the factory.

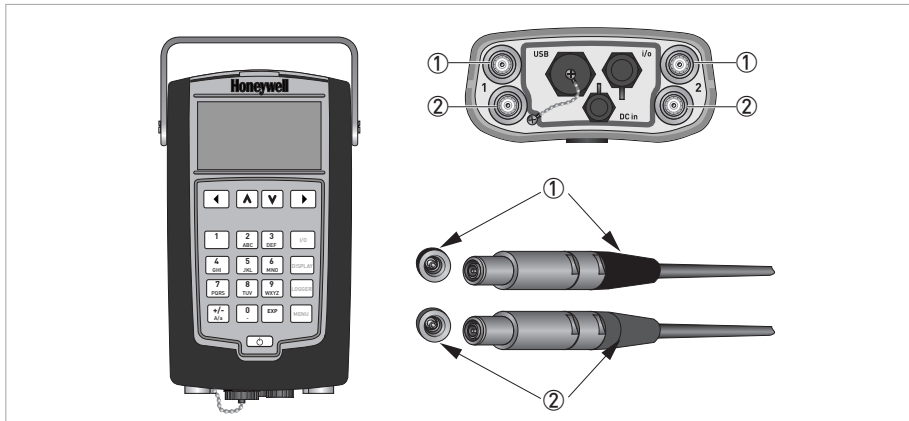

Figure 5-1: Connecting signal cables

- ① Connector for "UP" transducer (blue)
- ② Connector for "DOWN" transducer (green)



INFORMATION!

You can measure two paths with this converter simultaneously. Use the left pair of connectors for path 1 and the right pair for path 2.

5.5 USB connector

There are 2 USB connections available on the converter:

1. Read / write data to a memory stick with the USB connector (the converter acts as the master), for transferring data (log files and site files).
2. Control the converter with a PC (the converter acts as the slave) for file management. The memory of the converter appears as a memory in your explorer tree view, just like a memory stick.

1. Read / write data to a memorystick

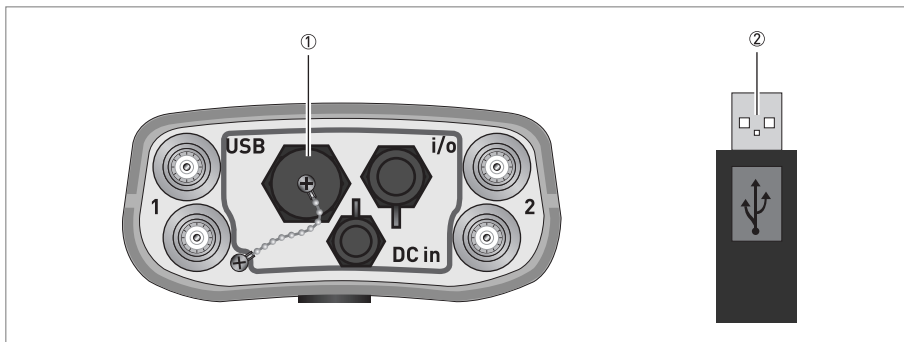

Figure 5-2: Connecting a memory stick to the converter

- ① Remove the protection cap by turning the knob counter clockwise
- ② Insert the memory stick

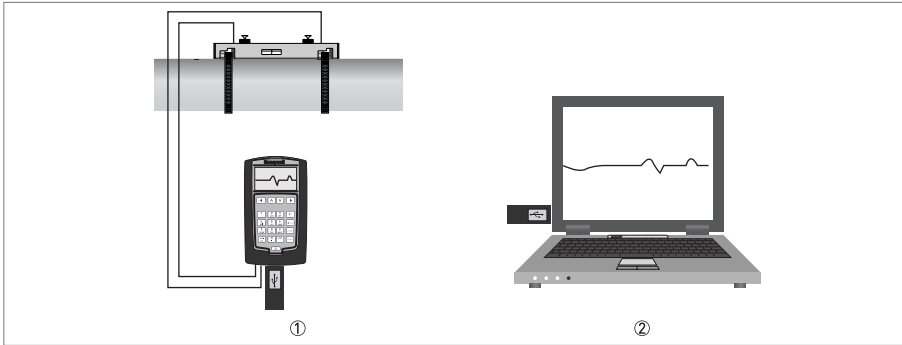

Figure 5-3: Using a memory stick for a measurement

- ① Perform a measurement on site and log the data to the memorystick
- ② Put the memory stick in your pc and evaluate the measurement.

2. Control the converter with a PC

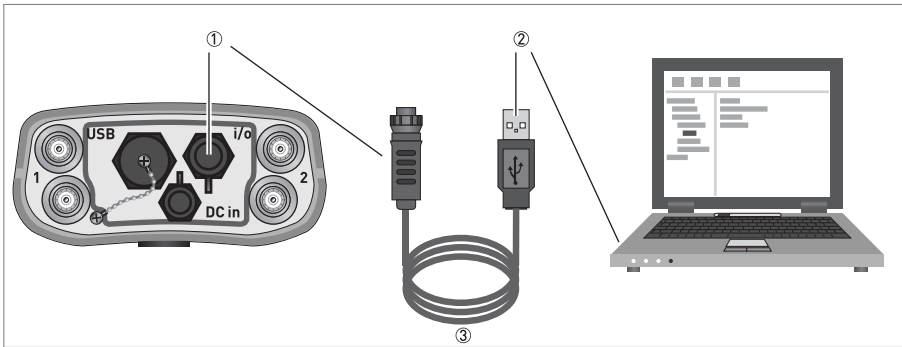

Figure 5-4: Connecting a pc to the converter

- ① I/O connector
- ② USB connector
- ③ optional USB / I/O cable

5.6 I/O cable

To use the available inputs and outputs of the converter, you need an optional I/O box. The I/O box is available in two versions (standard I/O functions and heat measurement version).

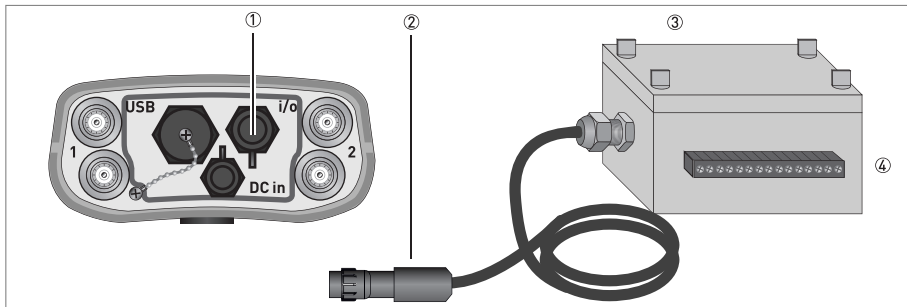

Figure 5-5: I/O box

- ① I/O connector on converter
- ② Connector of I/O box
- ③ I/O box with screw terminals for 1 mm² wiring
- ④ Screw terminal pin 1...15



- Plug the connector ② of the I/O box ③ in the connector ① of the converter. Then use the connectors ④ to setup the wanted I/O, as shown in the connection diagrams on the next pages.

Versions of I/O box

Screw terminal pin	Standard I/O box	I/O box with heat option
1	Frequency / pulse output D	Frequency / pulse output D
2	Frequency / pulse output D-	Frequency / pulse output D-
3	Status output X	Status output X
4	Status output X-	Status output X-
5	Current output C+	Current output C+
6	Current output C	Current output C
7	Current output C-	Current output C-
8	Current input A+	Temperature sensor 1 (PT 100, 4 wire connection)
9	Current input A-	
10	Current input B+	
11	Current input B-	
12	Not connected	Temperature sensor 2 (PT 100, 4 wire connection)
13	Not connected	
14	Not connected	
15	Not connected	

Table 5-1: Terminals of I/O box

5.7 Connection diagrams







	<p>mA meter 0...20 mA or 4...20 mA and other R_L is the internal resistance of the measuring point including the cable resistance</p>
	<p>DC voltage source (U_{ext}), external power supply, any connection polarity</p>
	<p>DC voltage source (U_{ext}), observe connection polarity according to connection diagrams</p>
	<p>Internal DC voltage source</p>
	<p>Controlled internal power source in the device</p>
	<p>Electronic or electromagnetic counter At frequencies above 100 Hz, shielded cables must be used to connect the counters. R_i Internal resistance of the counter</p>
	<p>Button, NO contact or similar</p>

Table 5-2: Description of symbols

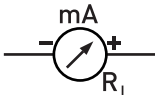
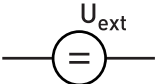

CAUTION!
Observe connection polarity.

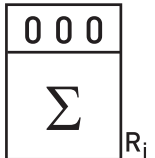
4...20 mA current output active

- $U_{int,nom} = 15 \text{ VDC}$ nominal
- $I \leq 22 \text{ mA}$
- $R_L \leq 600 \Omega$
- Not galvanically isolated.

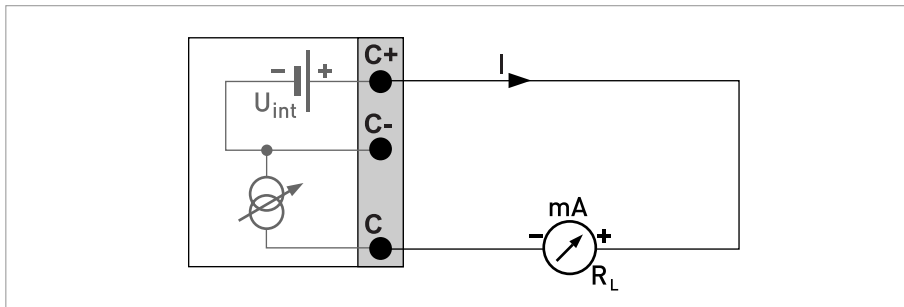

Figure 5-6: Current output active I_a

Current output passive, basic I/Os

- $U_{ext} \leq 32 \text{ VDC}$
- $I \leq 22 \text{ mA}$
- $U_0 \geq 1.8 \text{ V}$
- $R_L \leq (U_{ext} - U_0) / I_{max}$
- Not galvanically isolated.

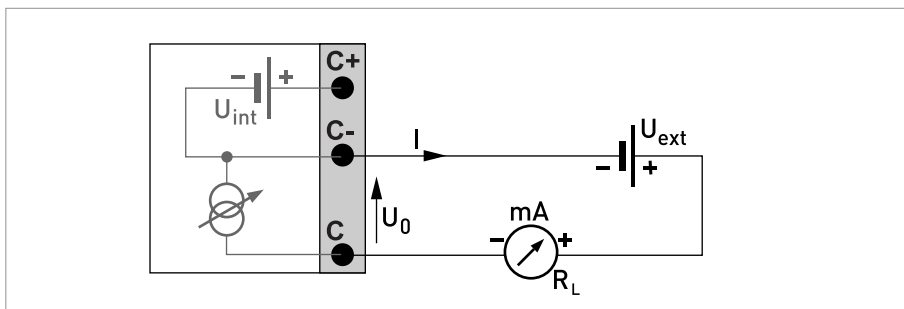

Figure 5-7: Current output passive I_p

**INFORMATION!****Pulse / frequency output**

- Any connection polarity.
- Galvanically isolated.

Pulse/frequency output passive

- $U_{\text{ext}} \leq 32 \text{ VDC}$
- f_{max} in operating menu set to $f_{\text{max}} \leq 100 \text{ Hz}$:
 $I \leq 100 \text{ mA}$
open:
 $I \leq 0.05 \text{ mA}$ at $U_{\text{ext}} = 32 \text{ VDC}$
closed:
 $U_{0, \text{max}} = 0.2 \text{ V}$ at $I \leq 10 \text{ mA}$
 $U_{0, \text{max}} = 2 \text{ V}$ at $I \leq 100 \text{ mA}$
- f_{max} in the operating menu set to $100 \text{ Hz} < f_{\text{max}} \leq 10 \text{ kHz}$:
 $I \leq 20 \text{ mA}$
open:
 $I \leq 0.05 \text{ mA}$ at $U_{\text{ext}} = 32 \text{ VDC}$
closed:
 $U_{0, \text{max}} = 1.5 \text{ V}$ at $I \leq 1 \text{ mA}$
 $U_{0, \text{max}} = 2.5 \text{ V}$ at $I \leq 10 \text{ mA}$
 $U_{0, \text{max}} = 5.0 \text{ V}$ at $I \leq 20 \text{ mA}$
- If the following maximum load resistance $R_{L, \text{max}}$ is exceeded, the load resistance R_L must be reduced accordingly by parallel connection of R:
 $f \leq 100 \text{ Hz}$: $R_{L, \text{max}} = 47 \text{ k}\Omega$
 $f \leq 1 \text{ kHz}$: $R_{L, \text{max}} = 10 \text{ k}\Omega$
 $f \leq 10 \text{ kHz}$: $R_{L, \text{max}} = 1 \text{ k}\Omega$
- The minimum load resistance $R_{L, \text{min}}$ is calculated as follows:
 $R_{L, \text{min}} = (U_{\text{ext}} - U_0) / I_{\text{max}}$
- Can also be set as a status output; for the electrical connection, see status output connection diagram.

Pulse/frequency output active

- $U_{\text{nom}} = 15 \text{ VDC}$
- f_{max} in operating menu set to $f_{\text{max}} \leq 100 \text{ Hz}$:
 $I \leq 20 \text{ mA}$
open:
 $I \leq 0.05 \text{ mA}$
closed:
 $U_{0, \text{nom}} = 15 \text{ V}$ at $I = 20 \text{ mA}$
- f_{max} in the operating menu set to $100 \text{ Hz} < f_{\text{max}} \leq 10 \text{ kHz}$:
 $I \leq 20 \text{ mA}$
open:
 $I \leq 0.05 \text{ mA}$
closed:
 $U_{0, \text{nom}} = 13.5 \text{ V}$ at $I \leq 1 \text{ mA}$
 $U_{0, \text{nom}} = 12.5 \text{ V}$ at $I \leq 10 \text{ mA}$
 $U_{0, \text{nom}} = 9.0 \text{ V}$ at $I \leq 20 \text{ mA}$

- If the following maximum load resistance $R_{L, \max}$ is exceeded, the load resistance R_L must be reduced accordingly by parallel connection of R :
 $f \leq 100 \text{ Hz: } R_{L, \max} = 47 \text{ k}\Omega$
 $f \leq 1 \text{ kHz: } R_{L, \max} = 10 \text{ k}\Omega$
 $f \leq 10 \text{ kHz: } R_{L, \max} = 1 \text{ k}\Omega$
- The minimum load resistance $R_{L, \min}$ is calculated as follows:
 $R_{L, \min} = (U_{\text{ext}} - U_0) / I_{\text{max}}$

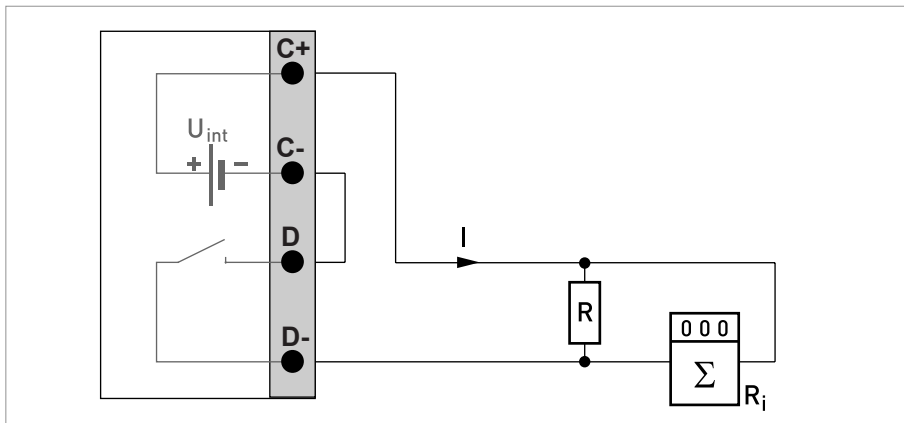

Figure 5-8: Pulse frequency output active P_a



INFORMATION!

- Any connection polarity.
- Galvanically isolated.

Status output

- $U_{\text{ext}} \leq 32 \text{ VDC}$
- $I \leq 100 \text{ mA}$
- $R_{L, \max} = 47 \text{ k}\Omega$
 $R_{L, \min} = (U_{\text{ext}} - U_0) / I_{\text{max}}$
- open:
 $I \leq 0.05 \text{ mA}$ at $U_{\text{ext}} = 32 \text{ VDC}$
 closed:
 $U_{0, \max} = 0.2 \text{ V}$ at $I \leq 10 \text{ mA}$
 $U_{0, \max} = 2 \text{ V}$ at $I \leq 100 \text{ mA}$
- The output is open when the device is de-energized.

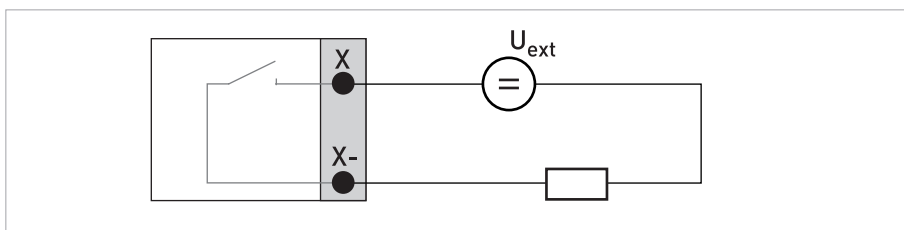

Figure 5-9: Status output / limit switch passive S_p

Current input active

- $U_{int, nom} = 15 \text{ VDC}$
- $I \leq 22 \text{ mA}$
- $I_{max} \leq 26 \text{ mA}$ (electronically limited)
- $U_{0, min} = 19 \text{ V}$ at $I \leq 22 \text{ mA}$
- **no** HART®
- Not galvanically isolated
- X designates the connection terminals A or B, depending on the version of the signal converter.

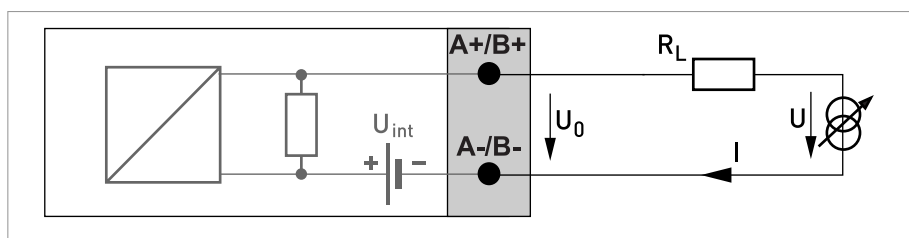

Figure 5-10: Current input active IIn_a

- ① Signal
- ② 2-wire transmitter (e.g. temperature)

6.1 Display configuration

6.1.1 Step 1: how to set up the display for showing measured values

There are two ways of setting up screens for showing measured values. Standard 4 information screens can be shown in the measuring mode. Additional screens showing graphs can be added when the datalogger is used. Setting up the display is done in menu nr. 2.4.3.1 via "Measurement ▶ Setup ▶ Display ▶ Screen setup". The following menu will be shown. Page 1 and 2 show parameters in numeric values or bar graphs or both, the graphical page shows trend graphs. The fourth page shows status and error messages.

2.4.3.1	
Page 1 Page 2 Graphical page Default page ▶	None (cyclic)
13-04-2010 14:11:09 13 MB free	

The appearance of the screens can be set. None (cyclic) means that the screen page will cycle through the 4 screens automatically. It is possible to define the default screen to display, for instance "1st meas. page".

2.4.3.1.4	
None (cyclic) 1st meas. page ▶ 2nd meas. page Graphical page Status page	
13-04-2010 14:11:09 13 MB free	



- Select 1st meas. page ▶

2.4.3.1.1	
Presentation mode 1 ▶ Low flow cutoff threshold Low flow cutoff hysteresis Time constant Line 1	1 line 0 % 0% 0.1 s
13-04-2010 14:11:09 13 MB free	



- Presentation mode: Program the number of lines (number of parameters) to be shown.
- Low flow cutoff threshold and hysteresis: Use the default values.
- Time constant: Only change the default value to a higher value if the signal is unstable.
- Line 1: Select the parameter to be shown and set the display format.



INFORMATION!

2nd meas. page can be programmed in the same way.



- Select Graphical page ▶

2.4.3.1.4	
None (cyclic)	
1st meas. page	
2nd meas. page	
Graphical page ▶	
Status page	
13-04-2010 14:11:09	13 MB free

2.4.3.1.3	
Parameter ▶	Volume flow
Range 0%	0.000 m3/h
Range 100%	540.0 m3/h
Minimum scale	-120 %
Maximum scale	120 %
Low flow cutoff threshold	0 %
low flow cutoff hysteresis	0 %
Time constant	0.1 %
13-04-2010 14:11:09	13 MB free



- Parameter: Select the parameter to be shown in the graph (Volume flow, Velocity of Sound or Temperature).
- Range 0% / 100%: Program the minimum and maximum value of the measurement
- Minimum scale / maximum scale: Program the minimum and maximum value of the axis in the graph.
- Low flow cutoff threshold / hysteresis: Use the default values.
- Time constant: Only change the default value to a higher value if the signal is unstable.

**INFORMATION!**

Additional screens showing trend graphs in measuring mode can be setup at the datalogger set up, go to "Measurement ▶ Setup ▶ Logger ▶ Logger setup ▶ View log in screens".

6.1.2 Basic settings of display

To change the brightness of the display, go to menu 2.4.3.2

2.4.3.2	
Brightness ▶	50 %
Sleep time	60 s
13-04-2010 14:11:09	13 MB free



- Brightness: Set the percentage of the maximum brightness.
- Sleep time: Set the time after which the display turns off if no key is pressed.

**CAUTION!**

Setting the brightness to 100% instead of 50% decreases the total operating time approximate 5%.

6.2 Programming the transducer calibration number



- Select Settings & information:

Menu	
Installation	
Measurement	
View logged data	
File management	
Settings & information ▶	
13-04-2010 14:11:09	13 MB free



- Select Transducer sets:

Settings & information	
Load factory settings	
Device	
Transducer sets	
Information	
Service	
13-04-2010 14:11:09	13 MB free



- Enter the data of the transducer sets Ta...Tc. The information is noted on a label on the cable of the transducers and on the calibration report.

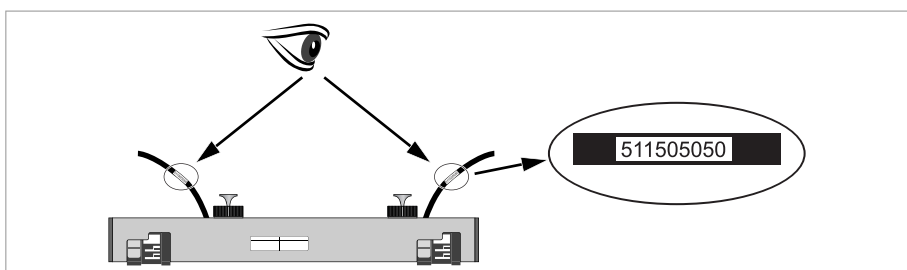

Figure 6-1: Calibration number on cable

5.3	
Ta serial number ▶	A10 xxxxx
Ta calibration number	511505050
Tb serial number	A10 xxxxxx
Tb calibration number	522505050
Tc serial number	
Tc calibration number	0
13-04-2010 14:11:09	13 MB free

6.3 Data logging

The measured data can be logged with the converter. The function of the data logger is explained in this chapter.

6.3.1 Step 1: how to set up the data logger



Figure 6-2: Location of keys

① Logger key



- Go to menu 2.4.4 with the logger button on the converter or via "Measurement ▶ Setup ▶ Logger".
- Select Logger setup.

2.4.4	
Start/stop logger now Set start time Set stop time Arm/disarm logger Logger setup ▶	
13-04-2010 14:11:09	13 MB free



INFORMATION!

It is advised to use the same name for the site file as for the data logger file.

2.4.4.5	
Filename ▶	12345678
Parameters	All
Sample interval	60 s
Event logging	
View log in screens	
13-04-2010 14:11:09	13 MB free



- **Filename:** Set a filename in which the logged data will be stored. The filename can have a maximum of eight characters, do not use the underscore character (_).



INFORMATION!

Automatically, three numbers will be added at the end of the filename, starting with "000". Every time a log file is created with the same filename, this number will be increased, eg 001, 002 etc.



- Parameters: Select which data must be logged (predefined sets of parameters "Flow", "Energy" or "Analysis"). Choose "Custom" to select your own set of parameters by setting each individual available parameter on or off.
- Sample interval: Set the interval at which the data is logged.
- Event loggings: Select if "status" or "limits" events must be logged.
- View log in screens: select if the logged data must be shown and how many screens must be used for it.

"Sample interval"

The standard sample interval is 60 s; this means that one data point is created every minute. The maximum number of data points in one file is 150000. If this number is exceeded during logging, the oldest data points are overwritten. The total memory size for data logging is sufficient for 50 files, each with 150000 data points.

Calculation examples:

Velocity of sound, supply temperature and flow speed must be logged one time per minute.

This means that 150000 data points / 3 = 50000 data points are available per subject. Required is one data point per minute, resulting in a maximum logging time of 50000 minutes = 833 hours.

Another example:

Volume flow and velocity of sound must be logged every five seconds.

This means that 150000 data points / 2 = 75000 data points are available per subject. Required is one data point per five seconds, so twelve data points per minute. The maximum logging time is 75000 / 12 = 6250 minutes (104 hours).

2.4.4.5	
Filename	log
Parameters	Custom
Sample interval	60 s ▶
Event logging	
View log in screens	
13-04-2010 14:11:09 13 MB free	

"Event logging" to log parameters exceeding pre-set limits and errors. To make use of event logging, data logging must be on. The event logging can be filled in fully independent from the data logging. The event logging will be logged on event regardless of the interval set.

The event logging can be set to "Status", the occurrence of a pre-defined event will be logged with time and date. The pre-defined events are "Error in device", "Application error", "Out of specification". for more information, refer to *Error messages* on page 36.

2.4.4.5	
Filename Parameters Sample interval Event logging ▶ View log in screens	log Custom 60 s
13-04-2010 14:11:09 13 MB free	

"Limit"

If the event logger is set to "Limit" the event of a parameter exceeding a pre-set limit can be logged.

"Measurement"

Choose the parameter for which the events should be logged.

"Threshold" and "Hysteresis"

The threshold is the limit setting. The hysteresis is the change required before the limit event can be logged again.

Example: Threshold is set to 10 m³/h, hysteresis to 1 m³/h. An event will be logged if the flow exceeds 10 m³/h. Another event can only be logged after the value has gone under 10-1= 9 m³/h.

"Polarity"

If the polarity stands on "Normal" the polarity of the parameter is regarded. If the polarity stands on "Absolute value" the direction of flow is not regarded and events will be logged at for example both negative and positive values.

"Direction"

"Normal" or "Inverse" shows the direction of exceeding the threshold setting in order to log an event. Normal is when the threshold value is passed by an increasing value of the parameter.

2.4.4.5.4.3	
Measurement ▶ Threshold Hysteresis Polarity Direction	Volume flow 180.0 m ³ /h 3.600 m ³ /h Normal Normal
13-04-2010 14:11:09 13 MB free	

6.3.2 Step 2: how to start data logging

2.4.4	
Start/stop logger now ▶	
Set start time	
Set stop time	
Arm/disarm logger	
Logger setup ▶	
13-04-2010 14:11:09	13 MB free

Data logging can only be done in the measurement mode.

Start logger now:

To start / stop the logger directly, select Start/stop logger now.

Start logger later:

To start the logger later, set a start and/or stop time and date for the logger. Then arm the logger. The logger will start/stop at the set date and time.

2.4.4	
Start/stop logger now ▶	
Set start time ▶	
Set stop time	
Arm/disarm logger	
Logger setup	
13-04-2010 14:11:09	13 MB free logging

6.3.3 Step 3: how to view logged data

With the TWS 2000 it is possible to view logged data. This is only possible for one logged parameter at the time.

"View logged data", ▶, choose saved file. Press ▶

View logged data	
Select log file	
Select parameter ▶	
13-04-2010 14:11:09	13 MB free

Choose a parameter and change the percent of the scale for viewing as required. Press "Next". A graph is displayed.

With the keys ▲ and ▼ zooming on the time scale axis is possible. The actual level of zooming is shown in the upper left corner as a percentage and through the bar on the time scale. After zooming in the 4 and 6 keys can be used to step to the beginning or the end of the data. The 1 and 3 key can be used to step backwards and forwards through the data.

6.4 How to transfer data to a PC

6.4.1 Site files

Site files are used to save and load all configured data from different applications / sites. At the startup of the converter, the site file is loaded that was last used. If no site file is present, the default site file will be used.

Site files can be saved and loaded in the "Measurement" menu. When a parameter setting is changed, the converter will ask if you want to save it when you enter the measuring mode.



CAUTION!

Make sure that site files have a valid name: minimum one character, maximum 12 characters and underscores (_) are not allowed.

In the menu "File management ▶ Site files" you can manage your site files. You can copy, rename or delete site files.

With the "Import" or "Export" option you can copy site files from/to a memory stick connected to the USB port.

It is highly recommended to backup your site files on a memory stick or on your pc.

The site files are XML files. You can store, copy or rename the site files on your pc, however if you edit a site file on your pc the site file might not have the correct format anymore and may give an error when reading it on the converter.

By saving the default site file the parameters settings of the factory are overwritten. To restore the factory default settings, select "Settings and information ▶ Load factory settings". If the default site file is deleted the converter will create a new one at the next startup of the device.

File management ▶ Site files	
Import ▶	
Rename	
Copy	
Export	
Delete	
13-04-2010 14:11:09	13 MB free

6.4.2 Log files

Log files can be managed on the converter itself. You can rename, copy or delete log files. You can find this option in the file management menu (4.2). All log files are stored on the converter as binary files.

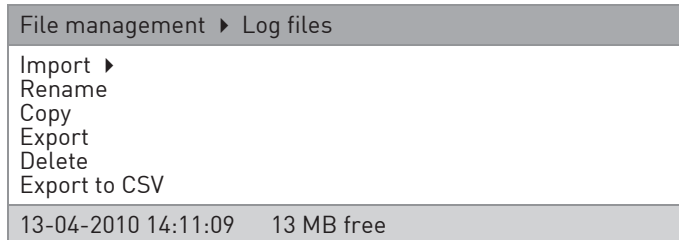

With the import and export function you can transfer the log files in their original format. The Export to CSV option is only possible when a memory stick is connected to the converter. The converter exports the log files to the memory stick as a CSV (Comma Separated Value) file.



INFORMATION!

The value's in the log file are separated with a ";" and "." is used as a decimal separator. A thousands separator is not used. Use the correct settings in Excel during the import of a CSV file.



CAUTION!

Make sure that log files have a valid name: minimum one character, maximum 12 characters and underscores (_) are not allowed.

6.4.3 Managing your files from your pc

The converter can be connected to a pc with a USB cable (option). The memory of the converter is shown in the explorer treeview on your pc in a similar way as a memory stick.

The site files are stored in \pcf\data\configuration (as .XML files).

The log files are stored in \pcf\data\log (as .log files).

You can copy the configuration and log files to your pc for backup and storage. You can copy configuration files that were created with the TWS 2000 emulation software on your pc.

You can copy log files that were created during earlier data logging sessions on a TWS 2000 to the TWS 2000.



CAUTION!

Do not create / change other files than the ones mentioned. Do not delete other files or folders from the signal converter.

When the converter is connected to your pc you can not convert log files to CSV format on the converter. This will only work with a memory stick connected to the converter.

Emulation of the signal converter operation on a pc

On the memory stick provided with the VersaFlow Sonic 2000 / TWS 2000 there is a folder "UFC400emul". In this folder there is a file named "pcf.exe". Start this program and you can load site files, change settings and store them. You can also convert logged data to CSV format. The CSV file will be stored in the \win32 folder. With this program of course there is no measurement function available.

6.5 Menu description

Menu Start-up

Menu item		Remarks
Language		Selection of language from list
Time and date		Enter date and time
Units		Selection of units from list
	Size	
	Volume flow	
	Text	Only if free unit is chosen
	m ³ /s factor	Only if free unit is chosen
	Velocity	
	Volume	
	Text	Only if free unit is chosen
	m ³ factor	Only if free unit is chosen
	Viscosity	
	Temperature	
	Temperature difference	
	Density	
	Text	Only if free unit is chosen
	kg/m ³ factor	Only if free unit is chosen
	Energy	
	Text	Only if free unit is chosen
	J factor	Only if free unit is chosen
	Power	
	Text	Only if free unit is chosen
	W factor	Only if free unit is chosen
	Specific heat	
Continue		

Menu 1: Installation

Menu nr	Menu item	Remarks
1	Pipe configuration	Selection from list
2	(Pipe 1 data 1)	
1	Pipe tag	
2	Outer diameter	
3	Material	
4	Wall thickness	
5	Liner material	
6	Liner thickness	
3	(Pipe 1 data 2)	
1	Fluid	
2	VoS fluid	

Menu nr		Menu item	Remarks
	3	Viscosity	
4		[Copy data pipe 1]	
5		[Pipe 2 data 1]	
	1	Pipe tag	
	2	Outer diameter	
	3	Material	
	4	Wall thickness	
	5	Liner material	
	6	Liner thickness	
6		[Pipe 2 data 2]	
	1	Fluid	
	2	VoS fluid	
	3	Viscosity	
7		[Sensor 1 advice]	
	1	Transducer set	
	2	Calibration number	
	3	Number of traverses	
8		[Sensor 1 position]	
	1	Advised Sensor position	
	2	Signal quality	
9		[Sensor 1 warning]	No check
	1	No signal	
	2	Shift sensor position	
	1	Gain	
	2	Signal quality	
	3	Change settings	
	4	Continue	
	5	Abort installation	
10		[Sensor 1 position]	
	1	Advised sensor position	
	2	Actual sensor position	
11		[Sensor 1 warning]	No check
	1	VoS out of range	
	2	Shift sensor position	
	1	Gain	
	2	Signal quality	
	3	Change settings	
	4	Continue	
	5	Abort installation	
12		[Sensor 1 test]	
	1	Volume flow	
	2	Velocity of sound	

Menu nr		Menu item	Remarks
	3	Signal quality	
	4	Optimize position	
13		[Sensor 2 advice]	
	1	Transducer set	
	2	Calibration number	
	3	Number of traverses	
14		[Sensor 2 position]	
	1	Advised transducer position	
	2	Signal quality	
15		[Sensor 2 warning]	No check
	1	No signal	
	2	Shift sensor position	
	1	Gain	
	2	Signal quality	
	3	Change settings	
	4	Continue	
	5	Abort installation	
16		[Sensor 2 position]	
17		[Sensor 2 warning]	No check
	1	VoS out of range	
	2	Shift sensor position	
	1	Gain	
	2	Signal quality	
	3	Change settings	
	4	Continue	
	5	Abort installation	
18		[Sensor 2 test]	
	1	Volume flow	
	2	Velocity of sound	
	3	Signal quality	
	4	Optimize position	
19		[Status]	
	1	Sensor 1 status	
	2	Signal quality	
	3	Sensor 2 status	
	4	Signal quality	
20		[Save site?]	
	1	Site name	
	2	Cancel	Move to main Menu
	3	Skip saving	Move to Measurement
	4	Save site file	Move to Measurement

Menu 2: Measurement

Menu nr						Menu item	Remarks
X						Site name	
1						Display measurements	
2						Load site	
3						Save current site	
4						Setup	
	1					Units	
		1				Size	
		2				Volume flow	Selection from list
						Text	Only if free unit is chosen
						m ³ /s factor	Only if free unit is chosen
		3				Velocity	
		4				Volume	Selection from list
						Text	Only if free unit is chosen
						m ³ factor	Only if free unit is chosen
		5				Viscosity	Selection from list
		6				Temperature	Selection from list
		7				Temperature difference	Selection from list
		8				Density	Selection from list
						Text	Only if free unit is chosen
						kg/m ³ factor	Only if free unit is chosen
		9				Energy	Selection from list
						Text	Only if free unit is chosen
						J factor	Only if free unit is chosen
		10				Power	Selection from list
						Text	Only if free unit is chosen
						W factor	Only if free unit is chosen
		11				Specific heat	Selection from list
	2					Process input	
		1				Pipe 1	
			1			Calibration	
				1		Zero calibration	Selection from list
				2		Meter factor	
				3		Reynolds correction	Selection from list
			2			Filter	
				1		Limitation minimum	
				2		Limitation maximum	
				3		Flow direction	Selection from list
				4		Time constant	
				5		Low flow cutoff treshold	
				6		Low flow cutoff hysteresis	

Menu nr				Menu item	Remarks
		3		Plausibility	
			1	Error limit	
			2	Counter decrease	
			3	Counter limit	
	2			Pipe 2	Same as "Pipe 1"
	3			Heat	
		1		Function	Selection from list
		2		Temperature input	Selection from list
		3		Supply temperature	
		4		Return temperature	
		5		Sensor location	Selection from list
		6		Fluid	
		7		Glycol % volume	(Water/Glycol mixture)
		8		Density	
		9		Specific heat	
	4			Volume flow calculation	Selection from list
3				Display	
	1			Screen setup	
		1		Page 1	
			1	Presentation mode	Selection from list
			2	Low flow cutoff threshold	
			3	Low flow cutoff hysteresis	
			4	Time constant	
			5	Line 1	
			1	Parameter	Selection from list ①
			2	Presentation format	Selection from list
			3	Range 0%	
			4	Range 100%	
			6	Line 2	
			1	Parameter	Selection from list ①
			2	Presentation format	Selection from list
			3	Range 0%	
			4	Range 100%	
		2		Page 2	Same as "Page 1"
		3		Graphical page	
			1	Parameter	Selection from list ①
			2	Range 0%	
			3	Range 100%	
			4	Minimum scale	
			5	Maximum scale	
			6	Low flow cutoff threshold	

Menu nr					Menu item	Remarks
			7		Low flow cutoff hysteresis	
			8		Time constant	
			9		Time scale	
		4			Default page	Selection from list
	2				Display settings	
		1			Brightness	
		2			Sleep time	
4					Logger	
	1				Start/stop logger now	Selection from list
	2				Set start time	
	3				Set stop time	
	4				Arm/disarm logger	Selection from list
	5				Logger setup	
		1			Filename	
		2			Parameters	
			1		All	
			2		Flow	
			3		Energy	
			4		Analysis	
			5		Custom	Selection from list ①
		3			Sample interval	
		4			Event logging	
			1		Function	Selection from list
			2		Status	Selection from list
			3		Limit	
				1	Measurement	Selection from list ①
					Threshold	
					Hysteresis	
				2	Polarity	Selection from list
				3	Direction	Selection from list
		5			View log in screens	
			1		number of screens	Selection from list
			2		Screen 1	
				1	Time scale	
				2	Layout	Selection from list
				3	Graph 1	
				1	Parameter	List acc. To "logger setup - Parameters selection"
				2	Minimum scale	
				3	Maximum scale	
				4	Graph 2	Same as "Graph 1"
				5	Graph 3	Same as "Graph 1"

Menu nr					Menu item	Remarks
				6	Graph 4	Same as "Graph 1"
			3		Screen 2	as Screen 1
			4		Screen 3	as Screen 1
			5		Screen 4	as Screen 1
5					I/O	
	1				Current output	
		1			Function	Selection from list
		2			Range 0%	
		3			Range 100%	
		4			Extended range min	
		5			Extended range max	
		6			Error current	
		7			Error condition	
		8			Measurement	Selection from list ①
		9			Range 0%	
		10			Range 100%	
		11			Polarity	Selection from list
		12			Limitation minimum	
		13			Limitation maximum	
		14			Low flow cutoff threshold	
		15			Low flow cutoff hysteresis	
		16			Time constant	
		17			4mA trimming	
		18			20mA trimming	
	2				Current inputs	
		1			Function	Selection from list
		2			Extended range A 0%	
		3			Extended range A 100%	
		4			Extended range B 0%	
		5			Extended range B 100%	
		6			Temperature range A 0%	
		7			Temperature range A 100%	
		8			Temperature range B 0%	
		9			Temperature range B 100%	
		10			Time constant A	
		11			Time constant B	
		12			4mA trimming A	
		13			20mA trimming A	
		14			4mA trimming B	
		15			20mA trimming B	

Menu nr				Menu item	Remarks
		3		Status output / limit switch	
			1	Function	Selection from list
			2	Status output	
			1	mode	Selection from list ①
			2	invert signal	Selection from list
			3	Limit switch	
			1	Measurement	Selection from list ①
			2	Threshold	
			3	Hysteresis	
			4	Polarity	Selection from list
			5	Time constant	
			6	Invert signal	Selection from list
		4		Frequency / pulse output	
			1	Function	Selection from list
			2	Frequency output	
			1	Pulse shape	Selection from list
			2	Pulse width	
			3	100% pulse rate	
			4	Measurement	Selection from list ①
			5	Range 0%	
			6	Range 100%	
			7	Polarity	Selection from list
			8	Limitation minimum	
			9	Limitation maximum	
			10	Low flow cutoff threshold	
			11	Low flow cutoff hysteresis	
			12	Time constant	
			13	Invert signal	Selection from list
			3	Pulse output	
			1	Pulse shape	Selection from list
			2	Pulse width	
			3	Maximum pulse rate	
			4	Measurement	Selection from list ①
			5	Pulse value unit	Selection from list
			6	Value per pulse	
			7	Polarity	Selection from list
			8	Low flow cutoff threshold	
			9	Low flow cutoff hysteresis	
			10	Time constant	
			11	Invert signal	Selection from list
		5		Simulation	

Menu nr				Menu item	Remarks
		1		Output	Selection from list
		2		Set simulation value	
6				Counters	
	1			Counter 1	
		1		Function of counter	Selection from list
		2		Measurement	Selection from list ①
		3		Low flow cutoff treshold	
		4		Low flow cutoff hysteresis	
		5		Preset value	
		6		Reset counter	Selection from list
		7		Set counter	
			1	Value	
			2	Set counter	Selection from list
		8		Stop counter	Selection from list
		9		Start counter	Selection from list
	2			Counter 2	Same as "Counter 1"
	3			Counter 3	Same as "Counter 1"
	4			Counter 4	Same as "Counter 1"
7				Reset errors	Selection from list

① Items shown are dependent on settings in other menu items, e.g. 1 pipe / 2 pipes, 1 path / 2 paths, energy on / off, flow calculation on / off etc.

Menu 3: View logged data

Menu nr		Menu item	Remarks
3		View logged data	
	1	Select log file	
	2	Select parameter	configured list
	3	(Range setting)	
		1 Offset	
		2 Limit	
		3 Next	
4	3	Next	

Menu 4: File management

Menu nr		Menu item	Remarks
1		Site files	Selection from list
	1	Import	
	2	Rename	
	3	Copy	
	4	Export	
	5	Delete	
2		Log files	

Menu nr	Menu item	Remarks
1	Import	
2	Rename	
3	Copy	
4	Export	
5	Delete	
6	Export to CSV	

Menu 5: Settings and information

Menu number	Menu item	Remarks
1	Load factory settings	Selection from list
2	Device	
1	Tag	
2	Language	
3	Time and date	
4	Start-up sequence ?	Selection from list
5	Password	In measuring mode the password blocks the measurement mode after the display sleep time has passed. The measurement mode can only be left after typing the password.
3	Transducer sets	
1	Ta serial number	
2	Ta calibration number	
3	Tb serial number	
4	Tb calibration number	
5	Tc serial number	
6	Tc calibration number	
4	Information	Information on hardware and software versions and serial numbers. Not required for day to day use but may be asked for when support from the supplier is required.
1	General	
	1 Identification number	
	2 Device serial number	
	3 Electronic serial number	
2	Components	
	1 Device	
	2 Sensor CPU	Same as "Device"
	3 Sensor DSP	Same as "Device"
	4 Sensor driver	Same as "Device"
	5 Current output	Same as "Device"
	6 Current input A	Same as "Device"
	7 Current input B	Same as "Device"
	8 UI controller	Same as "Device"
3	Operating hours	

Menu number			Menu item	Remarks
5			Service	These settings are specific for the ultrasonic measurement operation. Changing service settings may affect proper operation of the instrument. It is advised that changing of these parameters is performed by qualified engineers only.
	1		Signal data	
		1	Signal path 1	Selection from list
		2	Signal path 2	Selection from list
		3	Window path 1	
		1	Method	Selection from list
		2	Window size	
		3	Window weight	
		4	Window minimum	
		5	Window start	
		6	Window end	
		4	Window path 2	Same as "Window path 1"
		5	Detection path 1	
		1	Method	Selection from list
		2	Trigger level	
		3	Trigger margin	
		4	Dead time	
		6	Detection path 2	Same as "Detection path 1"
2			Service calibration	
	1		zero device	
		1	path 1	
		2	path 2	
	2		zero converter	
		1	path 1	
		2	path 2	
3			Reset to defaults	Selection from list

7.1 Spare parts availability

The manufacturer adheres to the basic principle that functionally adequate spare parts for each device or each important accessory part will be kept available for a period of 3 years after delivery of the last production run for the device.

This regulation only applies to spare parts which are subject to wear and tear under normal operating conditions.

7.2 Availability of services

The manufacturer offers a range of services to support the customer after expiration of the warranty. These include repair, maintenance, technical support and training.



INFORMATION!

For more precise information, please contact your local sales office.

7.3 Returning the device to the manufacturer

7.3.1 General information

This device has been carefully manufactured and tested. If installed and operated in accordance with these operating instructions, it will rarely present any problems.



CAUTION!

Should you nevertheless need to return a device for inspection or repair, please pay strict attention to the following points:

- *Due to statutory regulations on environmental protection and safeguarding the health and safety of our personnel, manufacturer may only handle, test and repair returned devices that have been in contact with products without risk to personnel and environment.*
- *This means that the manufacturer can only service this device if it is accompanied by the following certificate (see next section) confirming that the device is safe to handle.*



CAUTION!

If the device has been operated with toxic, caustic, flammable or water-endangering products, you are kindly requested:

- *to check and ensure, if necessary by rinsing or neutralising, that all cavities are free from such dangerous substances,*
- *to enclose a certificate with the device confirming that it is safe to handle and stating the product used.*

7.3.2 Form (for copying) to accompany a returned device

Company:		Address:	
Department:		Name:	
Tel. no.:		Fax no.:	
Manufacturer's order no. or serial no.:			
The device has been operated with the following medium:			
This medium is:	water-hazardous		
	toxic		
	caustic		
	flammable		
	We checked that all cavities in the device are free from such substances.		
	We have flushed out and neutralized all cavities in the device.		
We hereby confirm that there is no risk to persons or the environment through any residual media contained in the device when it is returned.			
Date:		Signature:	
Stamp:			

7.4 Disposal



CAUTION!

Disposal must be carried out in accordance with legislation applicable in your country.

8.1 Measuring principle

- Like canoes crossing a river, acoustic signals are transmitted and received along a diagonal measuring path.
- A sound wave going downstream with the flow travels faster than a sound wave going upstream against the flow.
- The difference in transit time is directly proportional to the mean flow velocity of the medium.

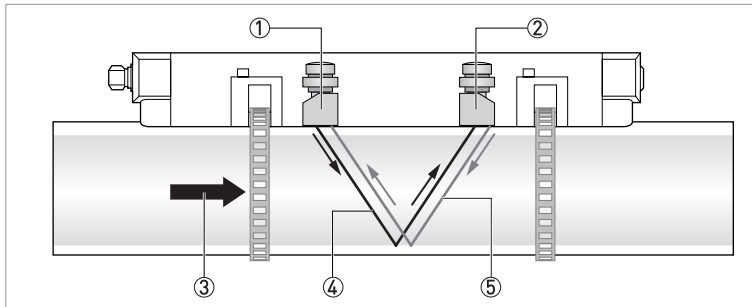

Figure 8-1: Measuring principle

- ① Transducer A
- ② Transducer B
- ③ Flow velocity
- ④ Transit time from transducer A to B
- ⑤ Transit time from transducer B to A

8.2 Technical data



INFORMATION!

- The following data is provided for general applications. If you require data that is more relevant to your specific application, please contact us or your local sales office.
- Additional information (certificates, special tools, software,...) and complete product documentation can be downloaded free of charge from the website.

Measuring system

Measuring principle	Ultrasonic transit time
Application range	Flow measurement of liquids
Measured value	
Primary measured value	Transit time
Secondary measured value	Volume flow, mass flow, flow speed, flow direction, speed of sound, gain, signal to noise ratio, diagnosis value, reliability of flow measurement, quality of acoustic signal, thermal energy (requires input of temperature (2x)).

Design

	The measurement system consists of one or two measuring sensors and a portable signal converter.
Signal converter	
Portable housing	TWS 2000
Measuring sensor	
Standard	Single or dual rail sensors with 1 or 2 MHz transducers
Optional	VersaFlow Sonic 1000 / TWS 9000 flow sensors using cable adapters
Diameter ranges	
DN15...150 / ½...6"	One rail, 2 MHz transducers Outer diameter must be at least 20 mm / ¾"
DN50...250 / 2...10"	One rail, 1 MHz transducers
DN200...1500 / 8...60"	Two rails, 1 MHz transducers
Options	
Outputs	0(4)...20 mA, pulse, frequency and/or status output
Inputs	0(4)...20 mA (2x) with optional I/O box.
Counters	4 internal counters with a maximum of 8 counter places, for counting volume, energy and/or mass units.
USB	1x host port (PC can use VersaFlow Sonic 2000 / TWS 2000 as a removable media device) 1x slave (memory stick can be written by converter)
Self diagnostics	Integrated verification, diagnostic functions: flowmeter, process, measured value, empty pipe detection, bar graph.

Display and user interface	
Graphic display	4.3" TFT with LED backlight, daylight readable
	272x480 dots resolution
	The readability of the display could be reduced at ambient temperatures below -25°C / -13°F.
Operator input elements	21 Key tactile keypad:
	1 on/off key
	4 cursor keys for menu operation
	12 keys for alpha / numerical input (SMS style)
	4 function keys for direct access to main functions
Display functions	
Menu	Wizard for setup and configuration of measurements.
	Support for the configuration of 2 path / 2 pipe or 2 path / 1 pipe measurement.
	Averaging, adding or subtracting of measurement results of 2 path measurements.
	Storage of measurement configurations as site file. Maximum of site files is 100.
	Measurement data can be displayed as value or as bar or trend graph.
Thermal energy measurement	By input of 2 temperature sensors providing a temperature difference, thermal energy can be calculated.
Data logger	Logging of selected measured / calculated values. Data to be logged and time interval can be set. A maximum number of 150000 values / 50 files can be stored. Display of logged data through line graphs.
Language of display texts	English, French, German, Italian, Spanish.
	Other languages on request.
Units	Metric, British and US units selectable from list / free unit.

Measuring accuracy

Reference conditions	Medium: water
	Temperature: 20°C / 68°F
	Straight inlet section: 10 DN
Maximum measuring error	±1% of the measured value for DN≥50 mm / 2" and v > 0.5 m/s / 1.5 ft/s
	±3% of the measured value for DN<50 mm / 2" and v > 0.5 m/s / 1.5 ft/s
Repeatability	<±0.2%

Operating conditions

Temperature	
Process temperature	Standard version: -40...+120°C / -40...+248°F
Ambient temperature	Sensor: -40...+70°C / -40...+158°F
	Signal converter: -20...+55°C / -4...+131°F (Humidity: 5...80%, non condensing)
Storage temperature	-30...+80°C / -22...+176°F (Humidity: 5...80%, non condensing)
Pipe specifications	
Material	Metal, plastic, ceramic, asbestos cement, internal / external coated pipes (coatings and liners fully bonded to pipe wall)
Pipewall thickness	< 200 mm / 7.87"
Liner thickness	< 20 mm / 0.79"
Media properties	
Physical condition	Liquids
Viscosity	< 100 cSt (general guideline)
	For detailed information please contact your local representative.
Permissible gas content (volume)	≤ 2%
Permissible solid content (volume)	≤ 5%
Recommended flow velocity	0.5...20 m/s

Installation conditions

Measurement configuration	Single pipe, single path
	Single pipe, dual path
	Dual pipe, dual path
Inlet run	≥ 10 DN straight length
Outlet run	≥ 5 DN straight length
Dimensions and weights	For detailed information refer to <i>Dimensions and weights</i> on page 88.

Materials

Sensor	Anodized aluminum (rail)
Converter	Polyamide PA12, covered with TPE soft touch layer on the sides
Trunk on wheels	Polypropylene

Electrical connections

Power supply	Adapter for 100...240 VAC (-10% / +10%), 47...63 Hz
	Adapter voltage: 13.2 V
	Maximum power consumption: 10 W (25 W during charging)
	Charging time: 8 hours
	Battery type: Lithium polymer
	Battery lifetime:
	Measuring operation (display at 50% brightness): 14 hours
Signal cable	double shielded, internal triax, length: 3 m / 15 ft
USB ports	1x for PC, 1x for memorystick
Inputs / outputs	15 pin connector for I/O interfacing with optional I/O box
	Optional: PT100 input:
	Function: PT 100 temperature input by 2x TT30C temperature transmitters build into an I/O box
	For specifications see TT30C datasheet.
	Optional: temperature input:
Function: temperature input by 2x TSR-W 30 clamp-on temperature sensors only in combination with I/O box with temperature transmitters.	
	For specifications see TSR-W 30 datasheet.

Inputs and outputs

Connections	Inputs and outputs can only be connected using the optional I/O box.
Description of used abbreviations	U_{ext} = external voltage R_L = load + resistance U_o = terminal voltage I_{nom} = nominal current
Current output	
Isolation	The output is not galvanically isolated from the other circuits.
Output data	All analog measurement parameters like volume and mass flow (at constant density), flow speed, speed of sound, gain, signal to noise ratio, reliability of flow measurement, quality of acoustic signal, thermal energy (requires input of temperature (2x)).
Settings	Q = 0%: 0...20 mA; Q = 100%: 10...21.5 mA
	Error identification: 0...22 mA
Operating data	
Active	$U_{int,nom}$ = 15 VDC $I \leq 22$ mA $R_L \leq 450 \Omega$
Passive	$U_{ext} \leq 32$ VDC $I \leq 22$ mA $U_o \geq 1.8$ V at $I = 22$ mA

Pulse or frequency output	
Isolation	The output is galvanically isolated from the other circuits.
Output data	For pulse counting and/or analog output: Volume flow, mass flow, thermal energy (requires input of temperature (2x))
	As analog output: Flow speed, speed of sound, gain, signal to noise ratio, reliability of flow measurement, quality of acoustic signal
Function	Can be set as a pulse output or frequency output
Settings	For Q = 100%: 0.01...10000 pulses per second or pulses per unit volume
	Pulse width: setting automatic, symmetric or fixed (0.05...2000 ms)
Operating data	
Active	$U_{nom} = 15 \text{ VDC}$
	$f_{max} \leq 100 \text{ Hz}$: $I \leq 20 \text{ mA}$ open: $I \leq 0.05 \text{ mA}$ closed: $U_{0,nom} = 15 \text{ V at } I = 20 \text{ mA}$
	$100 \text{ Hz} < f_{max} \leq 10 \text{ kHz}$: $I \leq 20 \text{ mA}$ open: $I \leq 0.05 \text{ mA}$ closed: $U_{0,nom} = 13.5 \text{ V at } I = 1 \text{ mA}$ $U_{0,nom} = 12.5 \text{ V at } I = 10 \text{ mA}$ $U_{0,nom} = 9 \text{ V at } I = 20 \text{ mA}$
Passive	$U_{ext} \leq 32 \text{ VDC}$
	$f_{max} \leq 100 \text{ Hz}$: $I \leq 100 \text{ mA}$ open: $I \leq 0.05 \text{ mA at } U_{ext} = 32 \text{ VDC}$ closed: $U_{0,max} = 0.2 \text{ V at } I \leq 10 \text{ mA}$ $U_{0,max} = 2 \text{ V at } I \leq 100 \text{ mA}$
	$100 \text{ Hz} < f_{max} \leq 10 \text{ kHz}$: $I \leq 20 \text{ mA}$ open: $I \leq 0.05 \text{ mA at } U_{ext} = 32 \text{ VDC}$ closed: $U_{0,max} = 1.5 \text{ V at } I \leq 1 \text{ mA}$ $U_{0,max} = 2.5 \text{ V at } I \leq 10 \text{ mA}$ $U_{0,max} = 5.0 \text{ V at } I \leq 20 \text{ mA}$

Status output	
Isolation	The output is galvanically isolated from the other circuits.
Function and settings	Settable as automatic measuring range change, indicator for direction of flow, overflow, error, operating point or empty pipe detection
	Status and/or control: ON or OFF
Operating data	
Active	$U_{int} = 15 \text{ VDC}$ $I \leq 20 \text{ mA}$ open: $I \leq 0.05 \text{ mA}$ closed: $U_{0, nom} = 15 \text{ V at } I = 20 \text{ mA}$
Passive	$U_{ext} \leq 32 \text{ VDC}$ $I \leq 100 \text{ mA}$ open: $I \leq 0.05 \text{ mA at } U_{ext} = 32 \text{ VDC}$ closed: $U_{0, max} = 0.2 \text{ V at } I \leq 10 \text{ mA}$ $U_{0, max} = 2 \text{ V at } I \leq 100 \text{ mA}$
Current inputs	
Isolation	The inputs are not galvanically isolated from the other circuits.
Function	Input of temperature, used for energy calculation in combination with flow measurement
	Range: -50...500°C / -58...932°F (default: 0...120°C / -32...248°F)
Operating data	
Active	$U_{int} = 15 \text{ VDC}$ $I \leq 22 \text{ mA}$ $I_{max} = 26 \text{ mA (electronically limited)}$ $U_{0, min} = 9 \text{ V with } I \leq 22 \text{ mA}$ No HART®
Passive	$U_{ext} \leq 32 \text{ VDC}$ $I \leq 22 \text{ mA}$ $I_{max} = 26 \text{ mA (electronically limited)}$ $U_{0, max} = 5 \text{ V with } I \leq 22 \text{ mA}$ No HART®

Approvals and certificates

CE	
	This device fulfills the statutory requirements of the EC directives. The manufacturer certifies successful testing of the product by applying the CE mark.
Electromagnetic compatibility	Directive: 2004/108/EC
	Harmonized standard: EN 61326-1: 2006
Low voltage directive	Directive: 2006/95/EC
	Harmonized standard: EN 61010: 2001
Other approvals and standards	
Protection category acc. to IEC 529 / EN 60529 / NEMA 250/2003	Sensor: IP 67 / NEMA 6
	Converter: IP 65 / NEMA 4
	Trunk on wheels: IP 67 / NEMA 6
	Power adapter: IP 40 / NEMA 1
Shock test sensor	IEC 60068-2-27
Vibration test sensor	IEC 60068-2-64

8.3 Dimensions and weights

8.3.1 Clamp-on sensor

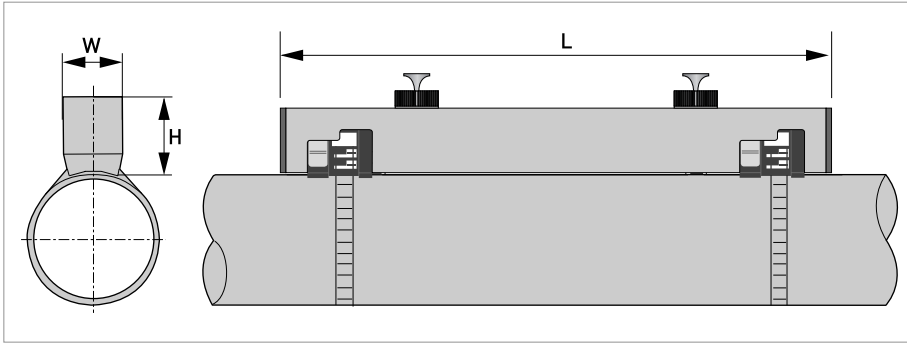

Dimensions [mm]			Approx. weight [kg]
L	H	W	
406	76	39.2	2.1 ①

① with transducers / cable, without mounting strap

Dimensions [inches]			Approx. weight [lb]
L	H	W	
16.0	3.0	2.5	4.6 ①

① with transducers / cable, without mounting strap

8.3.2 Converter

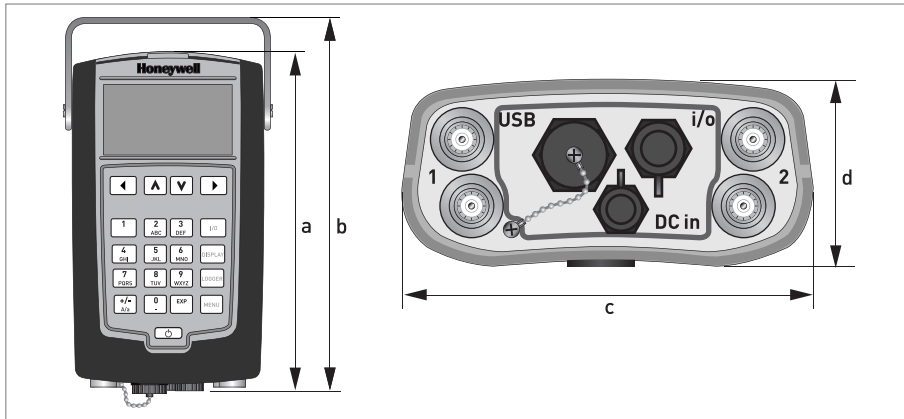

Dimensions TWS 2000 converter

Dimensions [mm]				Approx. weight [kg]
a	b	c	d	
247	289	168	66	1.6

Dimensions [inch]				Approx. weight [lb]
a	b	c	d	
9.7	11.4	6.6	2.6	3.5

8.3.3 I/O box

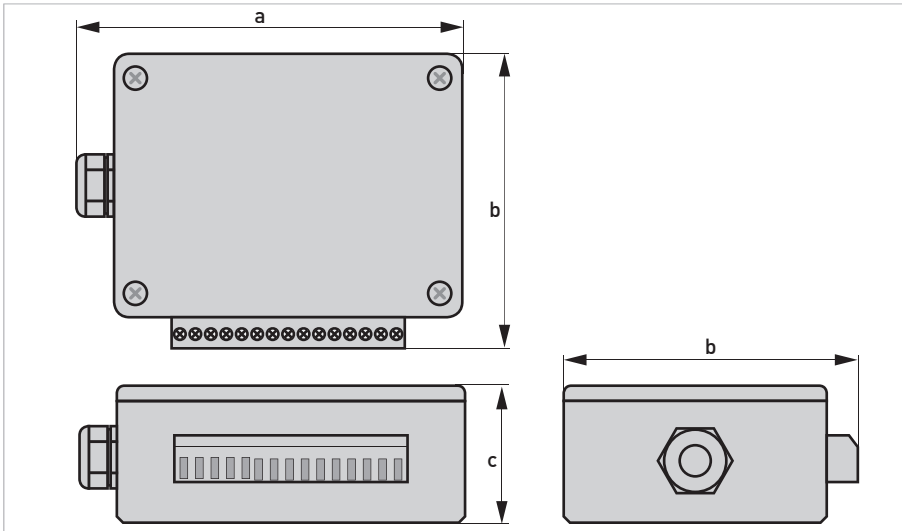

Dimensions I/O box

Dimensions [mm]			Approx. weight [kg]
a	b	c	
112.5	84.6	41.3	0.2

Dimensions [inch]			Approx. weight [lb]
a	b	c	
4.4	3.3	1.6	0.44

8.3.4 Trunk on wheels

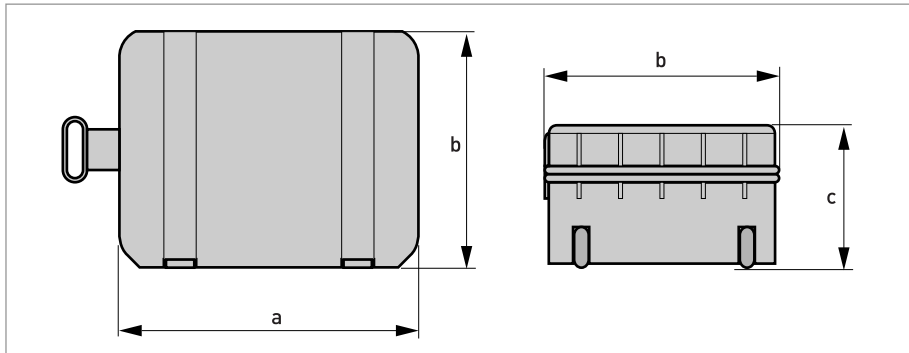

Dimensions trunk on wheels

Dimensions [mm]			Approx. weight [kg]
a	b	c	
565	374	241	6.2

Dimensions [inch]			Approx. weight [lb]
a	b	c	
22.2	14.7	9.5	13.7



Honeywell

AUTHORIZED DISTRIBUTOR

De Gidts & Feldman BV
The Netherlands
www.dgfg.nl



De Gidts & Feldman

INSTRUMENTATION & FILTRATION

Honeywell Field Solutions
512 Virginia Drive
Fort Washington, PA 19034
www.honeywell.com/ps

© Honeywell International Inc.
Subject to change without notice.