

DR4500A Classic Series Circular Chart Recorder With or Without Control Product Manual

Doc. No.: 44-45-25-35
Release: J
Last Revision Date: 6/07

Notices and Trademarks

Copyright 2007 by Honeywell
Release J – June, 2007

WARRANTY/REMEDY

Honeywell warrants goods of its manufacture as being free of defective materials and faulty workmanship. Contact your local sales office for warranty information. If warranted goods are returned to Honeywell during the period of coverage, Honeywell will repair or replace without charge those items it finds defective. The foregoing is Buyer's sole remedy and is in lieu of all other warranties, expressed or implied, including those of merchantability and fitness for a particular purpose. Specifications may change without notice. The information we supply is believed to be accurate and reliable as of this printing. However, we assume no responsibility for its use.

While we provide application assistance personally, through our literature and the Honeywell web site, it is up to the customer to determine the suitability of the product in the application.

Honeywell Field Solutions
Honeywell
512 Virginia Drive
Ft. Washington, PA 19034

DR4500 is a trademark of Honeywell

Modbus is a registered trademark of Modicon

Other brand or product names are trademarks of their respective owners.

About This Document

References

The following list identifies all documents that may be sources of reference for material discussed in this publication.

Document Title	Doc ID
How to Apply Digital Instrumentation in Severe Electrical Noise Environments	51-52-05-01
Modbus® RTU Serial Communications User Manual	51-52-25-66
Modbus® RTU Serial Communications user Manual Configuration Interface for DR4500 Supplement to 51-52-25-66	51-52-2569

Contacts

World Wide Web

The following lists Honeywell's World Wide Web sites that will be of interest to our customers.

Honeywell Organization	WWW Address (URL)
Honeywell Process Solutions	http://hpsweb.honeywell.com/








Telephone

Contact us by telephone at the numbers listed below.

	Organization	Phone Number
United States and Canada	Honeywell	1-800-423-9883 1-888-423-9883 1-800-525-7439
Asia Pacific	Honeywell Asia Pacific Hong Kong	(852) 2829-8298
Europe	Honeywell PACE, Brussels, Belgium	[32-2] 728-2111
Latin America	Honeywell, Sunrise, Florida U.S.A.	(854) 845-2600

Symbol Definitions

The following table lists those symbols used in this document to denote certain conditions.

Symbol	Definition
	This CAUTION symbol on the equipment refers the user to the Product Manual for additional information. This symbol appears next to required information in the manual.
	WARNING PERSONAL INJURY: Risk of electrical shock. This symbol warns the user of a potential shock hazard where HAZARDOUS LIVE voltages greater than 30 Vrms, 42.4 Vpeak, or 60 VDC may be accessible. Failure to comply with these instructions could result in death or serious injury.
	ATTENTION, Electrostatic Discharge (ESD) hazards. Observe precautions for handling electrostatic sensitive devices
	Protective Earth (PE) terminal. Provided for connection of the protective earth (green or green/yellow) supply system conductor.
	Functional earth terminal. Used for non-safety purposes such as noise immunity improvement. NOTE: This connection shall be bonded to protective earth at the source of supply in accordance with national local electrical code requirements.
	Earth Ground. Functional earth connection. NOTE: This connection shall be bonded to Protective earth at the source of supply in accordance with national and local electrical code requirements.
	Chassis Ground. Identifies a connection to the chassis or frame of the equipment shall be bonded to Protective Earth at the source of supply in accordance with national and local electrical code requirements.

Contents

1. Overview	1
1.1 Introduction	1
1.2 Operator Interface	3
1.3 Set-up Tasks	5
2. Installation	7
2.1 Overview	7
2.2 Model Number Interpretation	13
2.3 Mounting Considerations and Overall Dimensions	16
2.4 Mounting Methods	17
2.5 Wiring Prerequisites	27
2.6 Input Wiring Procedures	29
2.7 Output Wiring Procedures	39
2.8 Option Wiring Procedures	45
2.9 Lockout Switch Configuration	54
3. Configuration	55
3.1 Overview	55
3.2 Configuration Prompts	56
3.3 How To Get Started	58
3.4 Configuration Tips	59
3.5 Configuration Procedure	60
3.6 Input Set Up Group	62
3.7 Pen Set Up Group	64
3.8 Chart Set Up Group	65
3.9 Totalizer Set Up Group	66
3.10 Control Set Up Group	67
3.11 Tuning Parameters Set Up Group	69
3.12 SP Ramp Set Up Groups	70
3.13 Timer Set Up Group	71
3.14 Alarms Set Up Group	72
3.15 Auxiliary Output Set Up Group	74
3.16 Modbus Communications Set Up Group	75

3.17	Options Set Up Group	76
3.18	Lockout Set Up Group	77
3.19	Configuration Record Sheet	78
4.	Configuration Parameter Definitions	83
4.1	Overview.....	83
4.2	Input Parameters Set Up Group.....	84
4.3	Pen Parameters Set Up Group	88
4.4	Chart Parameters Set Up Group.....	90
4.5	Total Parameters Set Up Group.....	91
4.6	Control Parameters Set Up Group	93
4.7	Tuning Parameters Set Up Group.....	102
4.8	Setpoint Ramp Set Up Group.....	105
4.9	Timer Set Up Group	107
4.10	Alarms Set Up Group	108
4.11	Auxiliary Output Set Up Group	111
4.12	Modbus Communications Set Up Group.....	113
4.13	Options Set Up Group	114
4.14	Lockout Parameters Set Up Group	116
5.	Operation	117
5.1	Overview.....	117
5.2	Preparation	118
5.3	Start-up.....	120
5.4	Monitoring Your Recorder	123
5.5	Operator Functions.....	130
5.6	Operating Modes	131
5.7	Setpoints.....	133
5.8	Single Setpoint Ramp.....	135
5.9	Using Two Sets of Tuning Constants (PID Values)	138
5.10	Using Accutune II	141
5.11	Alarm Setpoints	144
5.12	Digital Input Option (Remote Switching)	145
5.13	Resetting and Displaying Totalizer Value	146
5.14	Monitoring the External Event Operation	148
5.15	Maximizing Pen Life	148
5.16	Routine Maintenance.....	149

5.17	Installing/Replacing Chart	150
6.	Setpoint Ramp/Soak Programming and Operation	151
6.1	Overview.....	151
6.2	Setpoint Program Contents	153
6.3	Drawing a Ramp/Soak Profile	156
6.4	Entering the Setpoint Program Data	161
6.5	SP RAMP1 and SP RAMP2 Set Up Group.....	163
6.6	Setpoint Program Profiles Set Up Group	165
6.7	Setpoint Program Segments Set Up Group	167
6.8	Setpoint Program Event Set Up Group	170
6.9	Run/Monitor the Program	174
7.	Input Calibration.....	177
7.1	Overview.....	177
7.2	Restoring Factory Calibration.....	178
7.3	Minimum and Maximum Range Values.....	180
7.4	Preliminary Information	181
7.5	Calibration Set Up and Wiring for PV Inputs	183
7.6	Calibration Procedure.....	192
8.	Output Calibration	195
8.1	Overview.....	195
8.2	Current Proportional Output/Aux Out 2 and 3 Calibration.....	196
8.3	Position Proportional Output Calibration	198
8.4	Auxiliary Output Calibration.....	201
9.	Troubleshooting / Service	203
9.1	Overview.....	203
9.2	Troubleshooting Aids.....	205
9.3	Self Diagnostics.....	207
9.4	Visual Failure Symptoms.....	213
9.5	Troubleshooting Procedures	214
9.6	Pen Alignment	220
10.	Parts List.....	223
10.1	Overview.....	223

10.2	Exploded Views	224
10.3	Miscellaneous Hardware Kit Contents	231
10.4	Internal Cabling Data – Without Options	232
10.5	Internal Wiring Diagram – Options Only	233
A.	Foreign Language Safety Instructions	237

Tables

Table 1-1	Function of keys	4
Table 2-1	Operating limits and condensed specifications	8
Table 2-2	Procedure to access components	14
Table 2-3	Mounting flush in a new panel cutout	18
Table 2-4	Reference data for mounting DR4500A in existing panel cutouts	19
Table 2-5	Mounting flush in a panel using universal filler kit	20
Table 2-6	Mounting flush in a panel using Kent Model 105M cutout	21
Table 2-7	Procedure for Mounting Recorder with NEMA4X Door	22
Table 2-8	Pipe Mounting Procedure	24
Table 2-9	Mounting flush on a surface (of panel or wall)	25
Table 2-10	Permissible wiring bundling	28
Table 2-11	AC line power wiring	31
Table 2-12	Thermocouple, RTD, Radiamatic, mV, or 0–5 Vdc input wiring	33
Table 2-13	4-20 mA input wiring	35
Table 2-14	0-10 Volt dc input wiring	37
Table 2-15	4-20 mA control output wiring	39
Table 2-16	Position proportional control output wiring	41
Table 2-17	Relay control output wiring	43
Table 2-18	Alarm output or digital input wiring	45
Table 2-19	Alarm 3 and Alarm 4 output wiring	47
Table 2-20	Alarm 5 and Alarm 6 output wiring	48
Table 2-21	RS485 Modbus communications wiring	50
Table 2-22	4-20 mA auxiliary output wiring	52
Table 3-1	Configuration tips	59
Table 3-2	Configuration procedure	60
Table 3-3	Input group function prompts	62
Table 3-4	Pen 1 or 2 group function prompts	64
Table 3-5	Chart group function prompts	65
Table 3-6	Totalizer group function prompts	66
Table 3-7	Control 1 or Control 2 group function prompts	67
Table 3-8	Tuning 1 or Tuning 2 group function prompts	69
Table 3-9	SP Ramp 1 or 2 group function prompts	70
Table 3-10	Timer group function prompts	71
Table 3-11	Priority of functions that operate relays	72
Table 3-12	Alarms group function prompts	73
Table 3-13	Auxiliary output group function prompts	74
Table 3-14	Modbus communications group function prompts	75
Table 3-15	Options group function prompts	76
Table 3-16	Lockout group function prompts	77
Table 4-1	Input group definitions	84
Table 4-2	Pen 1 or 2 group definitions	88
Table 4-3	Chart parameters group definitions	90
Table 4-4	Totalizer group definitions	91
Table 4-5	Control 1 or 2 group definitions	93
Table 4-6	Tuning group prompt definitions	102
Table 4-7	Setpoint Ramp 1 or 2 group definitions	105
Table 4-8	Timer group definitions	107
Table 4-9	Priority of functions that operate relays	108
Table 4-10	Alarms group definitions	109
Table 4-11	Auxiliary output group definitions	111
Table 4-12	Modbus communications group definitions	113
Table 4-13	Option group definitions	114
Table 4-14	Lockout group definitions	116

Table 5-1	Install/replace chart	118
Table 5-2	Set the chart time line procedure	120
Table 5-3	Power up diagnostic tests	120
Table 5-4	Procedure for testing the displays and keys	121
Table 5-5	Procedure for starting up the recorder	122
Table 5-6	Meaning of indicators	125
Table 5-7	Lower display key parameter prompts	127
Table 5-8	Error messages	128
Table 5-9	Alarm and tuning messages	129
Table 5-10	Operating mode definitions	131
Table 5-11	Changing operating modes	131
Table 5-12	Procedure for selecting automatic or manual mode	132
Table 5-13	Procedure for selecting the setpoint source	133
Table 5-14	Procedure for changing the local setpoint	133
Table 5-15	Procedure for switching between setpoints	134
Table 5-16	Setpoint selection indication	134
Table 5-17	Procedure for configuring a single setpoint ramp	135
Table 5-18	Procedure for running a setpoint ramp	136
Table 5-19	Procedure for selecting two sets of tuning constants	138
Table 5-20	Procedure for setting switchover values	139
Table 5-21	Procedure for setting tuning constant values	139
Table 5-22	Procedure for switching PID sets from the keyboard	140
Table 5-23	Procedure for starting Accutune II	141
Table 5-24	Procedure for using Accutune for duplex control	142
Table 5-25	Procedure for displaying or changing the alarm setpoints	144
Table 5-26	Digital input option action on contact closure	145
Table 5-27	Procedure for resetting the totalizer	146
Table 5-28	Procedure for displaying the totalizer value	147
Table 5-29	Maximizing pen life	148
Table 5-30	Changing the ink cartridge	149
Table 5-31	Replacing a chart lamp	149
Table 6-1	Parameter settings for example 12-step profile	157
Table 6-2	Setpoint program data entry procedure	161
Table 6-3	SP RAMP prompts and available selections	163
Table 6-4	Setpoint program profiles group definitions	165
Table 6-5	Setpoint program segments group definitions	167
Table 6-6	Setpoint program event group definitions	170
Table 6-7	Segment event relay operation requirements	171
Table 6-8	Run/Monitor functions	174
Table 7-1	Restoring factory calibration	178
Table 7-2	Voltage and resistance equivalents for 0% and 100% range values	180
Table 7-3	Disconnect the field wiring	181
Table 7-4	Equipment needed	182
Table 7-5	General set up procedure	184
Table 7-6	Set up wiring procedure for Thermocouple inputs using an ice bath	185
Table 7-7	Set up wiring procedure for Thermocouple inputs using a compensated calibrator method	186
Table 7-8	Set up wiring procedure for Thermocouple inputs using the ambient temperature method	187
Table 7-9	Set up wiring procedure for RTD inputs	188
Table 7-10	Set up wiring procedure for Radiomatic, Millivolts, and Volts inputs (except 0-10 Volts)	189
Table 7-11	Set up wiring procedure for 0–10 Volt inputs	190
Table 7-12	Set up wiring procedure for 4–20 mA inputs	191
Table 7-13	Calibration procedure sequence	192
Table 8-1	Set up wiring procedure current proportional output/Aux Out 2 and 3	196
Table 8-2	Current proportional output/Aux Out 2 and 3 calibration procedure	197
Table 8-3	Position proportional output calibration procedure	199

Table 8-4	Set up wiring procedure for auxiliary output.....	201
Table 8-5	Auxiliary output calibration procedure.....	202
Table 9-1	Procedure for identifying the software version	206
Table 9-2	Power-up tests	207
Table 9-3	Procedure for displaying the device status	208
Table 9-4	Error message prompts.....	209
Table 9-5	Visual failure symptoms.....	213
Table 9-6	Procedure #1—Troubleshooting recorder failure symptoms.....	214
Table 9-7	Procedure #2—Troubleshooting pen trace failure symptoms	215
Table 9-8	Procedure #3—Troubleshooting chart rotation failure symptoms.....	215
Table 9-9	Procedure #4—Troubleshooting erratic pen movement symptoms.....	216
Table 9-10	Procedure #5—Troubleshooting pen failure symptoms	216
Table 9-11	Procedure #6—Troubleshooting keyboard and/or display failure symptoms	216
Table 9-12	Procedure #7—Troubleshooting current proportional output failure symptoms.....	217
Table 9-13	Procedure #8—Troubleshooting position proportional output failure symptoms	217
Table 9-14	Procedure #9—Troubleshooting relay output failure symptoms.....	218
Table 9-15	Procedure #10—Troubleshooting current/time or time/current failure symptoms.....	218
Table 9-16	Procedure #11—Troubleshooting the auxiliary output	219
Table 9-17	Procedure #12—Troubleshooting external alarm function failure symptoms.....	219
Table 9-18	Procedure #13—Troubleshooting Modbus communications failure symptoms.....	219
Table 9-19	Pen 1 (purple) and Pen 2 (red) Mechanical Alignment	220
Table 9-20	Set the chart time line procedure	222
Table 10-1	Door assembly parts	224
Table 10-2	Chart plate assembly parts.....	226
Table 10-3	Basic recorder parts without options	228
Table 10-4	Recorder parts associated with options	230
Table 10-5	Miscellaneous hardware kit.....	231

Figures

Figure 1-1	Operator interface	3
Figure 1-2	Set-up tasks	5
Figure 2-1	Model number interpretation	13
Figure 2-2	DR4500A recorder hardware components versus “table” selections	15
Figure 2-3	Overall dimensions	16
Figure 2-4	How to remove knockouts	17
Figure 2-5	Mounting Flush in a New Panel Cutout	18
Figure 2-6	Mounting in a panel using universal filler kit	20
Figure 2-7	Mounting in a panel using Kent Model 105M cutout	21
Figure 2-8	Panel Mounting Recorder with NEMA4X Door	23
Figure 2-9	Pipe Mounting Brackets	24
Figure 2-10	Mounting flush on a surface (of panel or wall)	26
Figure 2-11	Ferrite filter locations and shield wiring (CE Mark)	30
Figure 2-12	AC line power wiring	32
Figure 2-13	Thermocouple, RTD, Radiamatic, mV, or 0–5 Vdc input wiring	34
Figure 2-14	4–20 mA input wiring	36
Figure 2-15	0–10 Volt dc input wiring	38
Figure 2-16	4–20 mA control output wiring (or Aux Out #2 and #3 wiring)	40
Figure 2-17	Position proportional control output wiring	42
Figure 2-18	Relay control output wiring	44
Figure 2-19	Alarm output or digital input wiring	46
Figure 2-20	Alarm outputs #3, 4, 5, and 6 wiring	49
Figure 2-21	RS485 Modbus communications wiring	51
Figure 2-22	4–20 mA auxiliary output wiring	53
Figure 2-23	S1 lockout switch location	54
Figure 3-1	DR4500A prompt hierarchy	56
Figure 5-1	Basic recording components	119
Figure 5-2	Operator interface	124
Figure 5-3	Deviation bargraph	126
Figure 6-1	Ramp/Soak profile example	156
Figure 7-1	Location of the input connections on the input boards	181
Figure 7-2	Location of jumper positions W1/MA and W3 on the input boards	183
Figure 7-3	Calibration set up diagram for Thermocouple inputs using an ice bath	185
Figure 7-4	Calibration set up diagram for Thermocouple inputs using a compensated calibrator method	186
Figure 7-5	Calibration set up diagram for Thermocouple inputs using the ambient temperature method	187
Figure 7-6	Calibration set up diagram for RTD inputs	188
Figure 7-7	Calibration set up diagram for Radiamatic, Millivolts, and Volts inputs (except 0–10 Volts)	189
Figure 7-8	Calibration set up diagram for 0–10 Volt inputs	190
Figure 7-9	Calibration set up diagram for 4–20 mA inputs	191
Figure 8-1	Test equipment connections for calibrating current proportional output	196
Figure 8-2	Test equipment connections for calibrating auxiliary output	201
Figure 9-1	Mechanical Alignment of Pens	221
Figure 10-1	Door assembly	224
Figure 10-2	Chart plate assembly	225
Figure 10-3	Basic recorder components without options	227
Figure 10-4	Recorder components associated with options	229
Figure 10-5	Internal cabling for DR4500A Classic recorder	232
Figure 10-6	Internal diagram for DR4500A Classic recorder – options only	233

1. Overview

1.1 Introduction

Function

The DR4500A Classic Series recorder combines the simplicity of pen drawn analog traces with the sophistication of microprocessor controlled functions. This combination results in a user configurable recorder that is easily adapted to meet a variety of application requirements—from blast furnace to laboratory.

In addition to recording analog traces, the Classic Series recorder continuously displays process variable values in the selected engineering units.

Both one-pen and two-pen models accept inputs from any one of a variety of sensors or transmitters within the configurable range limits. Also, models are available with one or two digital controllers to generate controlled output signals to operate valves, dampers, heating elements, etc. for process control.

CE Conformity (Europe)

Indicated models of this product are in conformity with the protection requirements of the following European Council Directives: **73/23/EEC**, the Low Voltage Directive, and **89/336/EEC**, the EMC Directive. Conformity of this product with any other “CE Mark” Directive(s) shall not be assumed.

Deviation from the installation conditions specified in this manual, and the special conditions for CE conformity in Section 2.1, may invalidate this product’s conformity with the Low Voltage and EMC Directives.



ATTENTION

The emission limits of EN 61326 are designed to provide reasonable protection against harmful interference when this equipment is operated in an industrial environment. Operation of this equipment in a residential area may cause harmful interference. This equipment generates, uses, and can radiate radio frequency energy and may cause interference to radio and television reception when the equipment is used closer than 30 meters (98 feet) to the antenna(e). In special cases, when highly susceptible apparatus is used in close proximity, the user may have to employ additional mitigating measures to further reduce the electromagnetic emissions of this equipment.

Microprocessor controlled recording and printing

Both the chart and the pen are driven by stepper motors which are controlled by the microprocessor with configurable chart speed through the keyboard.

The microprocessor uses the configured chart range data as well as the input data to determine the proper pen position.

The stepper motor accurately positions the pen drive without damping, thus eliminating the need for slidewire feedback gearing and drive cables.

A configurable deviation recording function lets users show graphically the difference between a reference input and a process variable input.

Users can designate the channel 1 input or enter a deviation setpoint value as the reference input.

Digital controller

The DR4500A recorder includes an integral microprocessor-based, PID controller with two loops of control. A variety of output types, including a duplex variation for heat cool applications, lets you select the output that is right for your final control element.

You can configure the control action as On-Off, PID-A, PID-B, or PD with manual reset. English language prompts guide you through the entry of all the controller's configurable parameters.

Construction

The DR4500 recorder is housed in a molded case which can be panel or surface mounted. A glass or acrylic windowed door protects the internal components while allowing easy access to the chart and operator interface. An optional external keypad that allows operator selections without opening the door is available.

Circuitry is partitioned on printed circuit boards for ease of service.

Power, input, and output wiring connect to terminations inside the case. Knockouts in the sides and bottom of the case accept conduit connections for convenient wire entry.

1.2 Operator Interface

Operator interface

Figure 1-1 shows the operator interface and defines the displays and indicators. The function of the keys is described in Table 1-1.

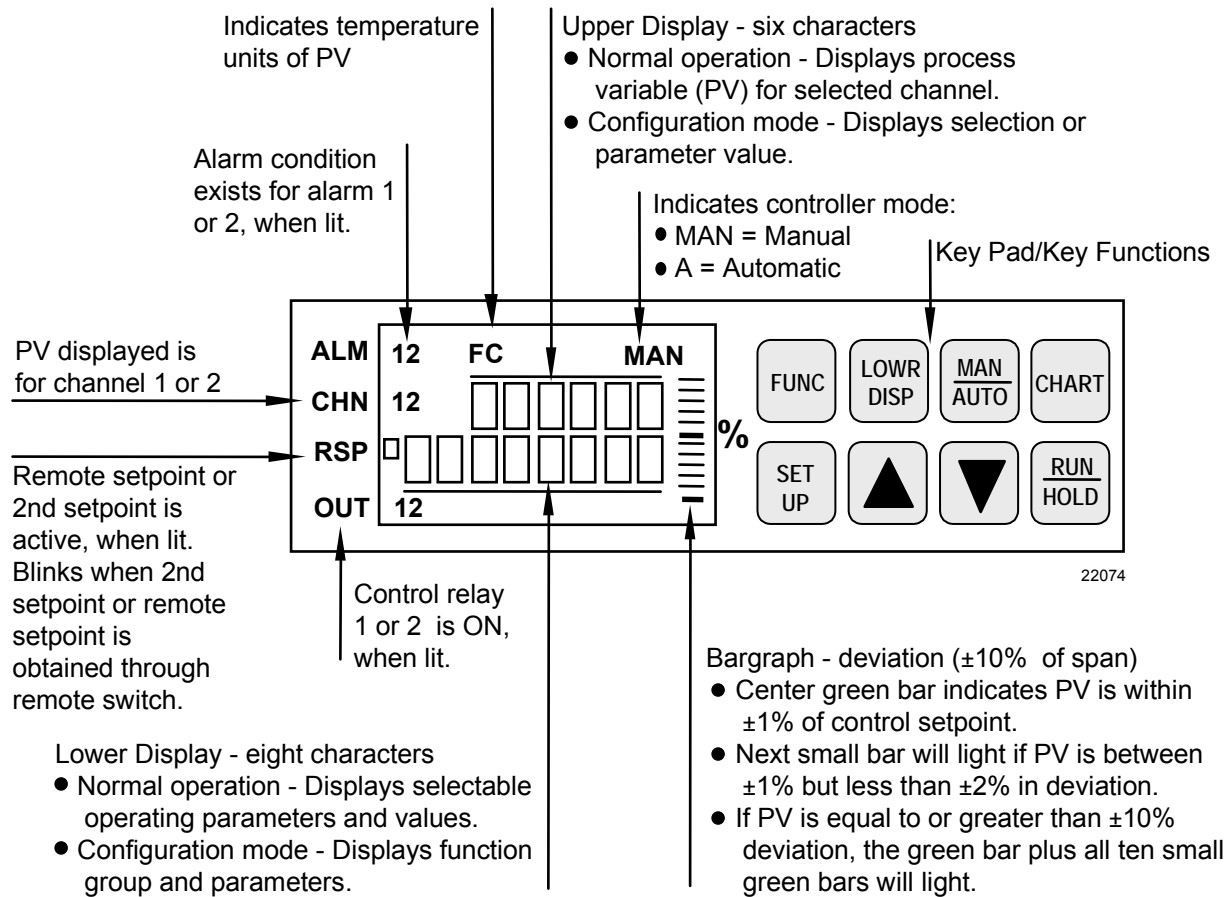


Figure 1-1 Operator interface

Key functions

Table 1-1 shows each key on the operator interface and defines its function.

Table 1-1 Function of keys

Key	Function
SET UP	<ul style="list-style-type: none"> Places the controller in the Configuration Set Up group select mode. Sequentially displays Set Up groups and allows the FUNC key to display individual functions in each Set Up group.
FUNC	<ul style="list-style-type: none"> Used in conjunction with the SET UP key to select the individual functions of a selected Configuration Set Up group. Used to toggle between SP1 and SP2. Used during field calibration procedure.
LOWR DISP	<ul style="list-style-type: none"> Selects an operating parameter to be shown in the lower display: <ul style="list-style-type: none"> OUT = Output Value SP = Local Setpoint 1 SPN = Current setpoint for setpoint rate applications 2SP = Local Setpoint 2 RSP = Remote Setpoint 2IN = Input 2 DEV = Deviation EU = PV Engineering Units RH = % RH Value PIDSETX = Tuning Parameter Set X=1 or 2 RAMP = Minutes remaining in Setpoint Ramp #RA = Minutes remaining in SP Prog Ramp #SK = Minutes remaining in SP Prog Soak RECYC = Number of recycles left in SP Program □.□□ = Time remaining in Timer function □.□□ = Time elapsed in Timer function TUNExXXX = Accutune II indicator. x = 1 or 2 <p>ATTENTION The lower display can be configured to scroll through the operating parameters.</p>
MAN AUTO	<ul style="list-style-type: none"> Alternately selects: <ul style="list-style-type: none"> AUTO Lower display automatically displays setpoint value in engineering units. MAN Lower display automatically indicates output in %.
CHART	<ul style="list-style-type: none"> Used to stop recording operation and move pen to outer limit for chart change.
RUN HOLD	<ul style="list-style-type: none"> Alternate action switch initiates or holds the Setpoint Ramp or Setpoint Program. In configuration mode, restores the original value or selection if you do not want to enter a change you are making to a parameter.
▲	<ul style="list-style-type: none"> Increases the setpoint, output, or configuration values displayed. Used to step through the items in each function while in configuration mode plus adjust control variables in the lower display.
▼	<ul style="list-style-type: none"> Decreases the setpoint, output, or configuration values displayed. Used to step through the items in each function while in configuration mode plus adjust control variables in the lower display.

1.3 Set-up Tasks

Major set-up tasks

As shown in Figure 1-2, there are four major tasks that you must complete to "Set Up" the DR4500A recorder for operation. For easy reference the section numbers for each task are shown.

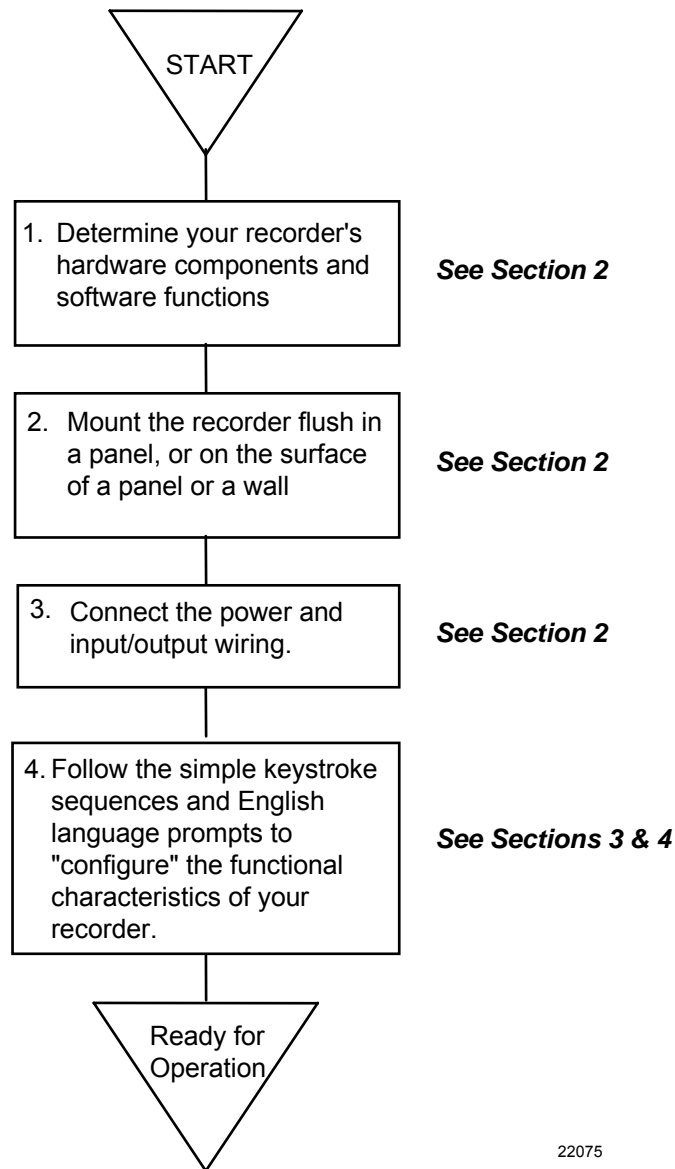


Figure 1-2 Set-up tasks

2. Installation

2.1 Overview

Introduction

Installation of the DR4500A Recorder consists of mounting and wiring the recorder according to the instructions given in this section.

Read the preinstallation information, check the model number interpretation and become familiar with your model selections, then proceed with installation.

What's in this section?

This section contains the following information:

	Topic	See Page
2.1	Overview	7
2.2	Model Number Interpretation	13
2.3	Mounting Considerations and Overall Dimensions	16
2.4	Mounting Methods	17
2.5	Wiring Prerequisites	27
2.6	Input Wiring Procedures	29
2.7	Output Wiring Procedures	39
2.8	Option Wiring Procedures	45
2.9	Lockout Switch Configuration	54

Pre-installation information

If the recorder has not been removed from its shipping carton, inspect the carton for damage and remove the recorder. Inspect the unit for any obvious shipping damage and report any damage due to transit to the carrier.

Make sure a bag containing mounting hardware is included in the carton with the recorder.

Check that the model number shown on the chart plate agrees with what you have ordered.

CE Conformity special conditions (Europe)

Shielded twisted pair cables are required for all Analog I/O, Process Variable, RTD, Thermocouple, dc millivolt, low level signal, 4-20 mA, and relay output circuits. Supplementary bonding of the recorder enclosure to a local ground, using 3/4" braided copper conductor, is required. Ferrite suppression filters (see Subsection 2.5 for Wiring Prerequisites) shall be installed on all cables connected to the recorder/controller. The cable shield drain wire at the cable load end requires connection through a 0.0047µf capacitor to ground.

Refer to document 51-52-05-01, *How to Apply Digital Instrumentation in Severe Electrical Noise Environments*, for additional installation guidance.

Operating limits and condensed specifications

We recommend that you review and adhere to the operating limits listed in Table 2-1 when you install your recorder.

Table 2-1 Operating limits and condensed specifications

Condition	Specifications
Ambient Temperature	32 to 131°F (0 to 55°C)
Relative Humidity	5 to 90% RH at 40°C (104°F)
Vibration Frequency Acceleration	0 to 200 Hz 0.2g
Mechanical Shock Acceleration Duration	5g 30 ms
Power	102 to 132 Vac 50/60 Hz 204 to 264 Vac 50/60 Hz
Power Consumption	20 watts maximum
Digital Indication Accuracy	1 digit
Minimum Input Span	Range is fully configurable with span limitation of the operating range selected.
Input Impedance	4-20 mA dc: 250 ohms 0-10 Vdc: 200K ohms All others: 10 Megohms
Source Impedance	RTD: 100 ohms per lead maximum
Span Step Response Time	6 seconds maximum with no filtering
Sampling Rate	Each input sampled 3 times a second
Input Filter	Software: Single pole low pass section with selectable time constants (off to 120 seconds).
Digital Displays	Vacuum fluorescent, alphanumeric. A six digit display dedicated to the process variable. Alternate information displayed during configuration mode. An eight digit display shows key selected operating parameters. Also provides guidance during configuration.
Indicators	Channel PV display (CHN 1 or 2) Alarm status (ALM 1, 2) Controller Output (OUT 1, 2) Remote Setpoint (RSP) Temperature unit (F or C) or Engineering Units Controller's mode (A or MAN)
Deviation Bargraph	21 segment, color coded deviation bargraph: Green (large) = On Control Green (small) = Deviation to ±10% of PV
Controller Modes of Operation	Manual Operation Automatic with local setpoint Automatic with remote setpoint

Condition	Specifications
Transmitter Supply Voltage	22 to 26 Vdc at input terminals (50 mA dc at 24 Vdc)
Controller Output¹ (Optional)	<ul style="list-style-type: none"> • <i>On-Off or Time Proportional</i> One SPST electromechanical relay. Control action can be set for direct or reverse; N.O. or N.C. contact selectable. • <i>On-Off Duplex or Time Proportional Duplex</i> Two SPST electromechanical relays. Control action can be set for direct or reverse; N.O. or N.C. contact selectable. • <i>Current Proportional</i> 21 mA dc maximum into a negative or positive grounded or non-grounded load of 0 to 1000 ohms. Output range can be set between 4 and 20 mA, and as direct or reverse action. <i>Resolution:</i> 10 bits <i>Accuracy:</i> 0.5% full scale FM Approved Output (optional) • <i>Position Proportional</i> Two SPST electromechanical relays operate motor having a 100 ohm to 1000 ohm slidewire. • <i>Current/Time Duplex and Time/Current Duplex</i> Variation of time proportional duplex for Heat/Cool applications. Time proportional output (heat or cool) is a SPST electromechanical relay. Current proportional output (heat or cool) is a 4-20 mA signal that can be fed into a negative or positive grounded load of 0 to 1000 ohms and is operational over 50% of range or the entire range. <i>Time Proportional Relay Resolution:</i> 4.4 mSec Relay Contact Ratings: Resistive Load: 5A @ 120 Vac, 2.5A @ 240 Vac Inductive Load: 50 VA @ 120 Vac or 240 Vac Cycle Time: 1 to 120 seconds <i>Current Proportional:</i> Resolution: 10 bits Accuracy: 0.5% full scale
Auxiliary Output (Optional)	<p>21 mA dc maximum into a negative or positive grounded load of 0 to 1000 ohms. The range can be set between 0 to 21 mA. It can be configured to represent any one of 10 control parameters: Input 1-2, PV1-2, Deviation 1-2, Output 1-2, Setpoint 1-2. Auxiliary Output 2 and Auxiliary Output 3 use Control Current Output 1 and Control Current Output 2 if Control "OUTALG" is not set to "CURRENT".</p> <p><i>Resolution:</i> 12 bits over 0 to 21 mA <i>Accuracy:</i> 0.2% of full scale <i>Temperature Stability:</i> 0.03% F.S./°C</p>

Installation - Overview

Types of Input Actuators	Range		Reference Accuracy		Temp Stability ± Degrees Error Per 1 Degree ΔT
	°F	°C	± °F	± °C	
Thermocouples²					
B	105 to 3300 105 to 150 150 to 500 500 to 1000 1000 to 3300	41 to 1816 41 to 66 66 to 260 260 to 538 538 to 1815	42.00 14.00 3.00 1.50	23.00 7.70 1.70 0.80	2.00 2.00 0.50 0.20
E	-454 to 1832 -454 to -202 -202 to 1832	-270 to 1000 -270 to -130 -130 to 1000	18.00 1.00	10.00 0.55	0.70 0.35
E (low)	-200 to 1100	-129 to 593	0.50	0.30	0.20
J	0 to 1600	-18 to 871	0.40	0.22	0.06
J (low)	20 to 770	-7 to 410	0.20	0.11	0.04
K	-320 to 2500 -320 to 0 0 to 2500	-196 to 1371 -196 to -18 -18 to 1371	1.25 0.60	0.70 0.35	0.18 0.09
K (low)	-20 to 1000	-29 to 538	0.30	0.16	0.05
NNM (Ni Ni Moly)	32 to 2500 32 to 500 500 to 2500	0 to 1371 0 to 260 260 to 1371	0.75 0.50	0.40 0.30	0.09 0.07
NIC (Nicrosil-Nisil)	0 to 2372	-18 to 1300	1.0	0.55	0.01
R	0 to 3100 0 to 500 500 to 3100	-18 to 1704 -18 to 260 260 to 1704	2.00 1.00	1.10 0.55	0.25 0.13
S	0 to 3100 0 to 500 500 to 3100	-18 to 1704 -18 to 260 260 to 1704	2.00 1.00	1.10 0.55	0.23 0.13
T	-300 to 700	-184 to 371	0.60	0.35	0.07
T (low)	-200 to 600	-129 to 316	0.40	0.22	0.07
W5W26	0 to 4200 0 to 600 600 to 3600 3600 to 4200	-18 to 2315 -18 to 316 316 to 1982 1982 to 2315	1.40 1.30 1.60	0.77 0.70 0.90	0.17 0.17 0.29
W5W26 (low)	0 to 2240 0 to 600 600 to 2240	-18 to 1227 -18 to 316 316 to 1227	1.10 1.00	0.60 0.55	0.14 0.10
Radiamatic	1400 to 3400	760 to 1871	1.00	0.55	0.10
RTD					
Platinum					
100 ohms	-300 to 900	-184 to 482	0.40	0.22	0.05
500 ohms	-300 to 900	-184 to 482	0.20	0.11	0.05

Types of Input Actuators	Range		Reference Accuracy		Temp Stability ± Degrees Error Per 1 Degree ΔT
	°F	°C	± °F	± °C	
Linear					
Milliamperes dc	4 to 20	—	0.10%	—	0.004%/°F
Millivolts dc	0 to 10 10 to 50	—	0.05% 0.05%	—	0.004%/°F 0.004%/°F
Volts dc	1 to 5 (can be calibrated 0 to 5) 0 to 10	—	0.05% 0.10%	—	0.004%/°F 0.004%/°F
Relative Humidity Platinum 100 ohm Wet/Dry Bulb*					
Wet/Dry Input	-130 to 392	-90 to 200	0.30	0.03	0.03
%RH³	Measured %RH	Dry Bulb Range		Reference Accuracy	Temp. Stability 53 to 104°F/12 to 40°C
		°F	°C		
	0 to <20 20 to 100	-103 to 212 35 to 40 >40 to 100 100 to 212	-75 to 100 2 to 4 >4 to 38 38 to 100	2% RH 2% RH 1% RH 1% RH	0.11% RH/°F 0.11%RH/°F 0.06% RH/°F 0.03% RH/°F

Condition	Specifications
Case	Molded, foamed-Noryl** with gasketed door. A UL and FM approved NEMA4X door is also available.
Pen	Disposable fiber-tip ink cartridge. line length per cartridge more than 1000 ft. (305 m). <i>One pen:</i> Purple <i>Two pens:</i> Purple and red
Chart	12-inch (304.8 mm) diameter chart with standard preprinted markings and a calibrated width of 4.62 inches (117.5 mm)
Wiring Connections	Terminals inside the case.
Color	<i>Case:</i> Black <i>Door (standard):</i> Caribbean Blue, Black, or Gray
Approval Bodies	U.L. approval depending on model. CSA approval. Consult Model Selection Guide for information. FM approved for Class I, Div. 2, Groups A, B, C, D areas depending on model.
Weight	13.2 lbs (6 kg)
Mounting	Panel, pipe, or surface mounted. Some adapter kits available for existing panel cutouts.
OPTIONS	
Alarm Output	Two, four, or six relays available. Relays 3 through 6 available if not used for control outputs. <i>Relay Contact Ratings:</i> <i>First Relays, Resistive Load:</i> 1A @ 120 Vac, 1/2A @ 240 Vac <i>Relays 3 through 6, Resistive Load:</i> 5A @ 120 Vac, 2.5A @ 240 Vac
Digital Input	+20 Vdc source for external dry contact or isolated solid state contacts. Selects one configured input.
Totalizers	One or two totalizers depending on model. Eight digit "totals" with multiplier on digital display.

Condition	Specifications
RS485 Modbus RTU Communications	<i>Baud rate:</i> 300, 600, 1200, 2400, 4800, 9600, 19200, 38400 <i>Protocol:</i> RS485 Modbus RTU Communications <i>Length of Link:</i> 4000 ft (1,219 m) maximum <i>Link Characteristics:</i> Two-wire, multidrop
Miscellaneous	<ul style="list-style-type: none"> • FM Approved 4-20 mA Control Output • A UL and FM approved NEMA4X door • Door Lock • External Keypad • Chart Illumination • U.L. Listing, FM Approval/CSA, CE Conformity • Control with Accutune II Tuning capability • Glass or Acrylic Window • Configuration Lockout Switch • Customer ID Tag (30 characters maximum)
CE Conformity (Europe)	This product is in conformity with the protection requirements of the following European Council Directives: 73/23/EEC , the Low Voltage Directive, and 89/336/EEC , the EMC Directive. Conformity of this product with any other “CE Mark” Directive(s) shall not be assumed.
Product Classification	Class 1: Permanently connected, Panel/Surface Mounted Industrial Control Equipment with protective earthing (grounding). (EN 61010-1)
Enclosure Rating	Panel/Surface Mounted Equipment, IP 54. (ref. IEC 529)
Installation Category (Overvoltage Category)	Category II: Energy-consuming equipment supplied from the fixed installation. Local level appliances, and Industrial Control Equipment. (EN 61010-1)
Pollution Degree	Pollution Degree 2: Normally non-conductive pollution with occasional conductivity caused by condensation. (ref. IEC 664-10)
EMC Classification	Group 1, Class A, ESM Equipment (EN 55011, emissions), Industrial Equipment (EN 50082-2, immunity)
Method of EMC Assessment	Technical File (TF)
Declaration of Conformity	Document #51197635-000

*IEC Alpha (α) = 0.00385 $\Omega/\Omega/^\circ\text{C}$

**Registered Trademark—General Electric Co.

¹ Not all controller outputs are available on all models of the Classic Recorder. Consult Model Selection Guide for information.

² Includes reference junction calibration of ± 0.01 degrees using standard “ice bath” method of calibration. Factory calibration at reference $\pm 1.2^\circ\text{F}$. Note that factory calibration may vary by as much as ± 10 microvolts or ± 0.3 ohms for RTDs, which means recalibration may be required to achieve stated accuracy.

³ The RH calculation is inoperative when temperature goes below 32°F (0°C) or above 212°F (100°C). However, the dry bulb temperature will be monitored to -103°F (-75°C). Accuracy stated is for Classic Series Recorder only, and does not include remaining system accuracies.

2.2 Model Number Interpretation

Model number

The model number interpretation is shown in Figure 2-1. Write the model number into the spaces provided and compare it to the model number interpretation. This information will also be useful when you wire your recorder. The example on the next page will help you to decode the model.

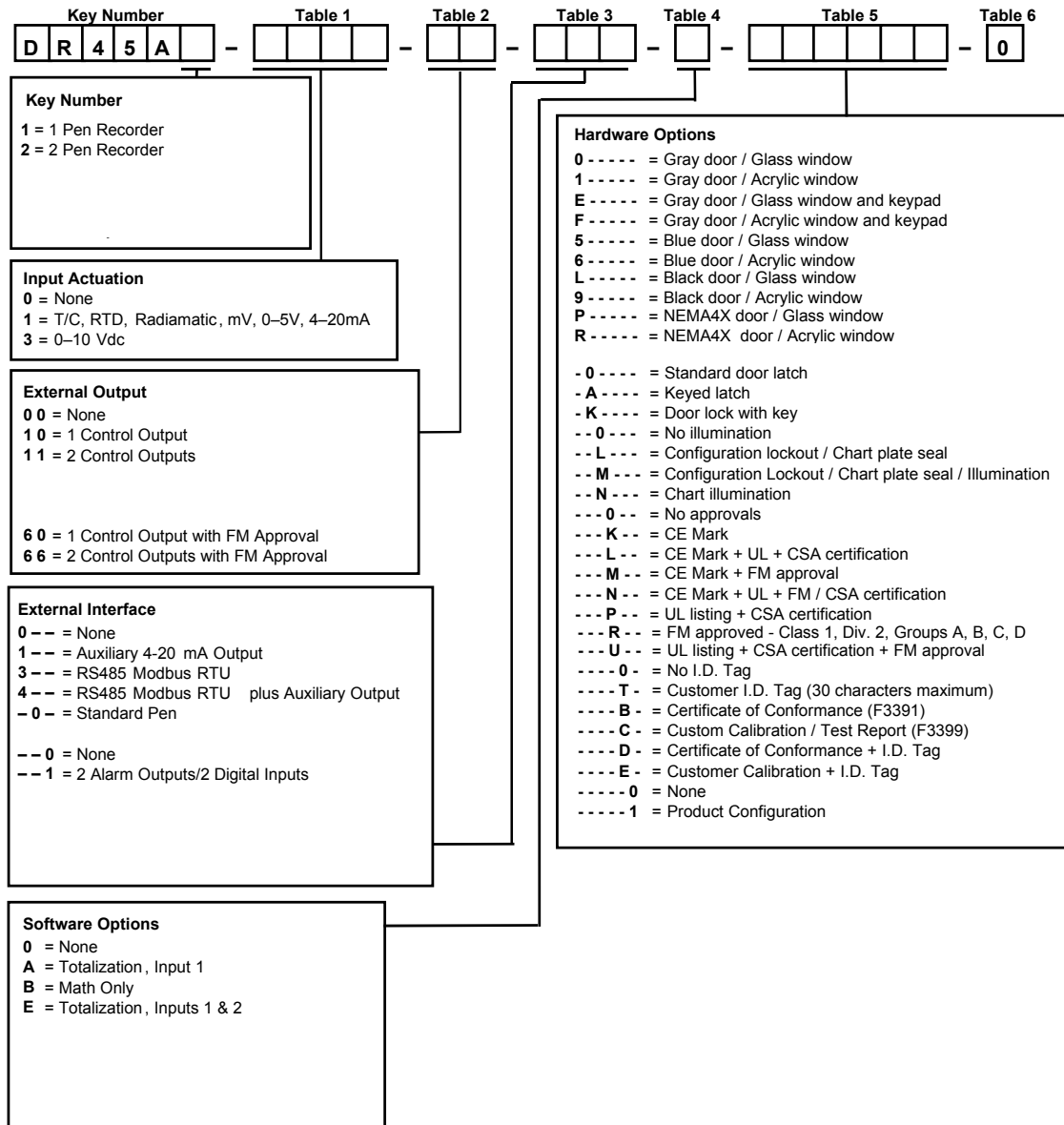


Figure 2-1 Model number interpretation

Example of model number decoding

Assume that the model number on the label is

DR45A2 - 1300 - 10 - 001 - A - 1KN0T0 - 0

Using the table code definitions from Figure 2-1, this recorder has the following features and options:

- 2-input type with thermocouple, RTD, Radiamatic, mV, 0-5 Vdc or 4-20 mA input for channel 1
- 0-10 Vdc input for channel 2
- One controller output
- Alarm output / digital input capability
- Totalization for input 1
- Gray door with acrylic window
- Door lock
- No approvals
- Chart illumination
- Customer I.D. tag

Location of hardware components

After you decode your recorder's model number, refer to Figure 2-2 to match "table" selections with the location of actual recorder hardware components. This will help you to determine applicable input / output wiring requirements, as well as identify appropriate software functions to be configured later.

To access and view the actual components inside your recorder, follow the procedure in Table 2-2.

Table 2-2 Procedure to access components

Step	Action
1	Turn the latch on the recorder door and swing the door open.
2	Loosen the captive screw on the right hand side of the chart plate and swing the chart plate out.
3	Reverse the steps to close the chart plate and door.

View of hardware components

Figure 2-2 shows the location of the actual hardware components for key number DR45A1 or DR45A2.

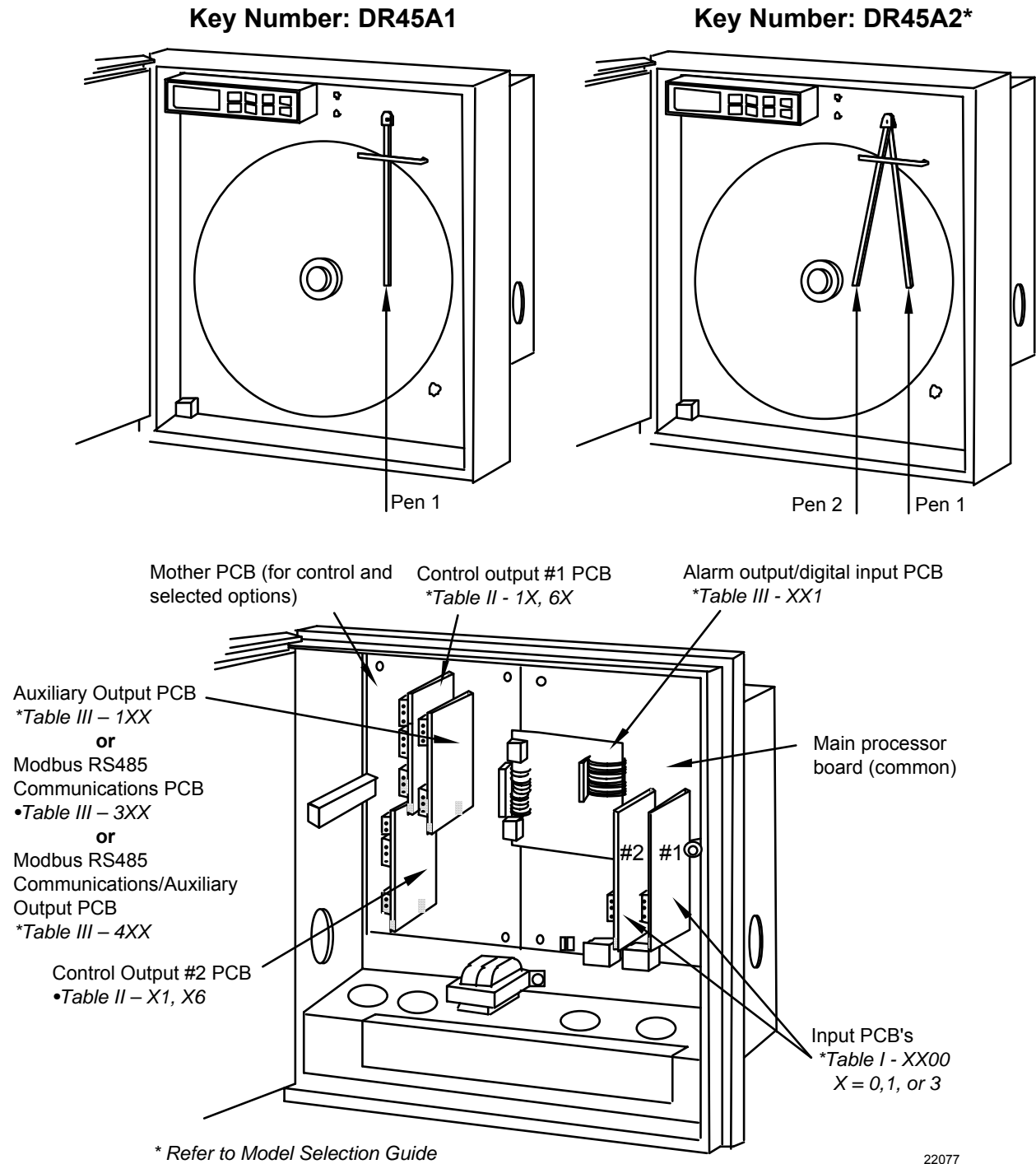


Figure 2-2 DR4500A recorder hardware components versus “table” selections

2.3 Mounting Considerations and Overall Dimensions

Physical considerations

The recorder can be mounted in a panel by making a new cutout or using an existing cutout with a filler plate (see Table 2-4). Use the mounting kit supplied. Adequate access space must be available at the back of the panel for installation and servicing activities.

The overall dimensions and panel cutout requirements for mounting the recorder are shown in Figure 2-3.

Overall dimensions

Figure 2-3 shows the overall dimensions for mounting the recorder.

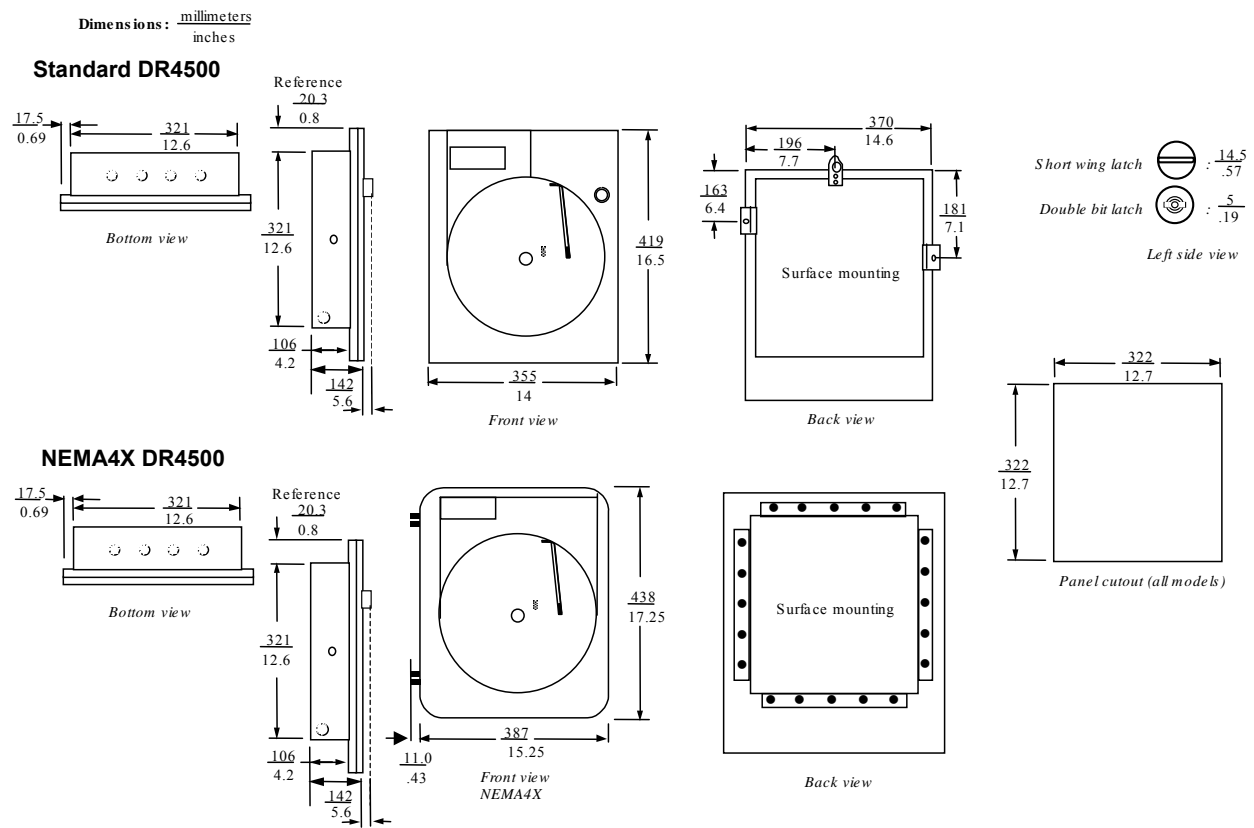


Figure 2-3 Overall dimensions

2.4 Mounting Methods

Introduction

There are several methods available for mounting your recorder. They are:

- Flush in Panel (new panel cutout)
- Flush in Panel (using an existing panel cutout)
 - using universal filler plate kit
 - using cutout made for Kent Model 105M
- Flush in Panel for recorders with NEMA4 Door
- On a 2-inch Pipe
- On Surface (of panel or wall)

Procedures for each method follow. Choose the one that meets your mounting requirements. Use the associated dimension drawings for reference.

How to remove knockouts for conduits

Before you mount the recorder, remove the appropriate “knockouts” in the bottom and/or sides of the recorder case for wire entry via 1/2" (12.7mm) conduits. Refer to Figure 2-4 for knockout locations.



ATTENTION

The knockouts are really plugs that you just have to push out to remove.

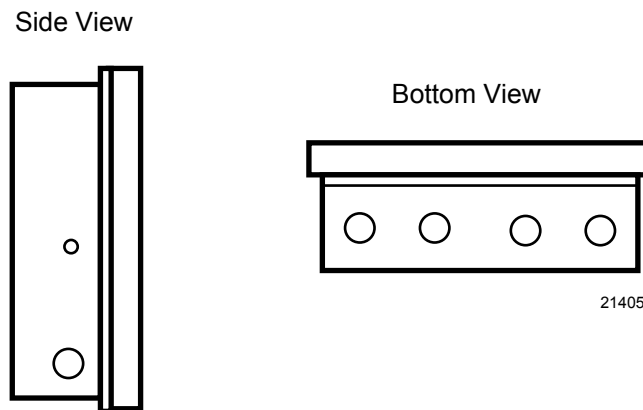


Figure 2-4 How to remove knockouts

Mounting flush in panel (New panel cutout)

Refer to Figure 2-5 and follow the procedure in Table 2-3 to make a new cutout in a panel and mount your recorder in the cutout.

Table 2-3 Mounting flush in a new panel cutout

Step	Action
1	At the appropriate location, make a square cutout in the panel measuring 12.7 ±0.060 inches by 12.7 ±0.060 inches (322.58 ±1.52 by 322.58 ±1.52 millimeters). See Figure 2-3.
2	Orient the recorder case properly and slide it into the cutout from the front of the panel. Support the recorder as shown in steps 3 and 4.
3	Refer to Figure 2-5. From the back of the panel, attach a mounting bracket to each side of the recorder case using a 1/4-20 x 1/2 inch hex screw and a lockwasher for each bracket (mounting hardware supplied with recorder). Leave the screws slightly loose so you can adjust the brackets.
4	While holding the recorder firmly against the panel, slide each bracket against the back of the panel and tighten the screws.

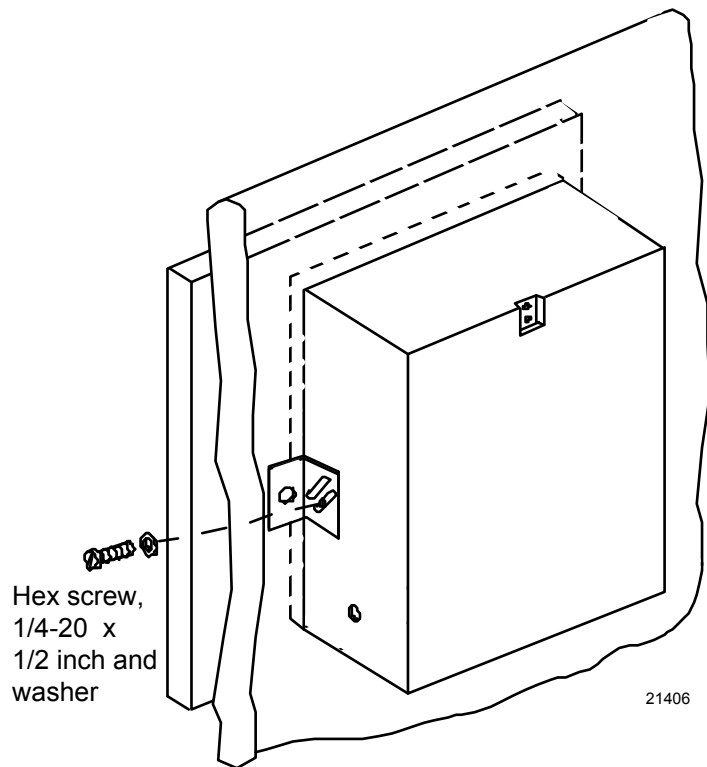


Figure 2-5 Mounting Flush in a New Panel Cutout

Reference data for existing panel cutouts

Refer to Table 2-4 to determine whether the existing panel cutout can be used. Use the procedure for mounting with the universal filler kit unless otherwise noted.

Table 2-4 Reference data for mounting DR4500A in existing panel cutouts

Manufacturer / Instrument	Dimensions of Existing Panel Cutout (inches)	Need Universal Filler Plate Kit 30755134-001 Blue Color 30755134-002 Gray Color
Honeywell/Model AR100*, DR4200	12.7 x 12.7	No*
Honeywell/Class 15	15.8 x 17.2	Yes
Honeywell/Class 45	13.12 x 17.12	Yes
Badger Meter/Model Micro Chart	14.25 x 17.88	Yes
Bristol/Models 4330, 500 Classes 1, 2A, 3B, and 5	3.56 x 18.56	Yes
Fisher and Porter/Model 51-1100	13.75 x 17.31	Yes
Foxboro/Model 40	14.38 x 17.06	Yes
Kent/Model 105M**	13.6 x 13.46	No**
Partlow/Model ER*	13.5 x 12.69	No*
Taylor/Model 76J	13.78 x 16.5	Yes

*No adaptation is required, use procedure for "Flush in Panel - New Panel Cutout"

**Use procedure for "Cutout made for Kent Model 105M"

Adapter plate dimensions

The dimensions of the adapter plate (part number 30755134) are 16.5" x 19".

Mounting flush in panel (using universal filler plate kit)

Refer to Figure 2-6 and follow the procedure in Table 2-5 to mount your recorder in an existing cutout using the Universal Filler Kit.

Table 2-5 Mounting flush in a panel using universal filler kit

Step	Action
1	Lay the recorder face down on a clean work surface and position the universal filler plate as shown in Figure 2-6.
2	Measure the height of the existing panel cutout.
3	Refer to Figure 2-6. Position the support brackets, supplied with the kit, so that the distance from the top of the "window" in the filler plate to the right angle of the support brackets is just less than the height of the existing panel cutout.
4	Secure brackets with two 10-32 x 1/4 inch screws, provided in the kit, by inserting them through the holes in the filler plate into the tapped screw holes in the recorder case.
5	Insert the recorder into the cutout from the front of the panel as shown in Figure 2-6.
6	Refer to Figure 2-6. From the back of the panel attach a mounting bracket to each side of the recorder case using a 1/4-20 x 1/2-inch hex screw and a lockwasher for each bracket (mounting hardware supplied with recorder). Leave the screws slightly loose so you can adjust the brackets.
7	While holding the recorder firmly against the panel, slide each bracket against the back of the panel and tighten the screws.

NOTE: Universal filler plate and attaching hardware are included in kit 30755134-xxx

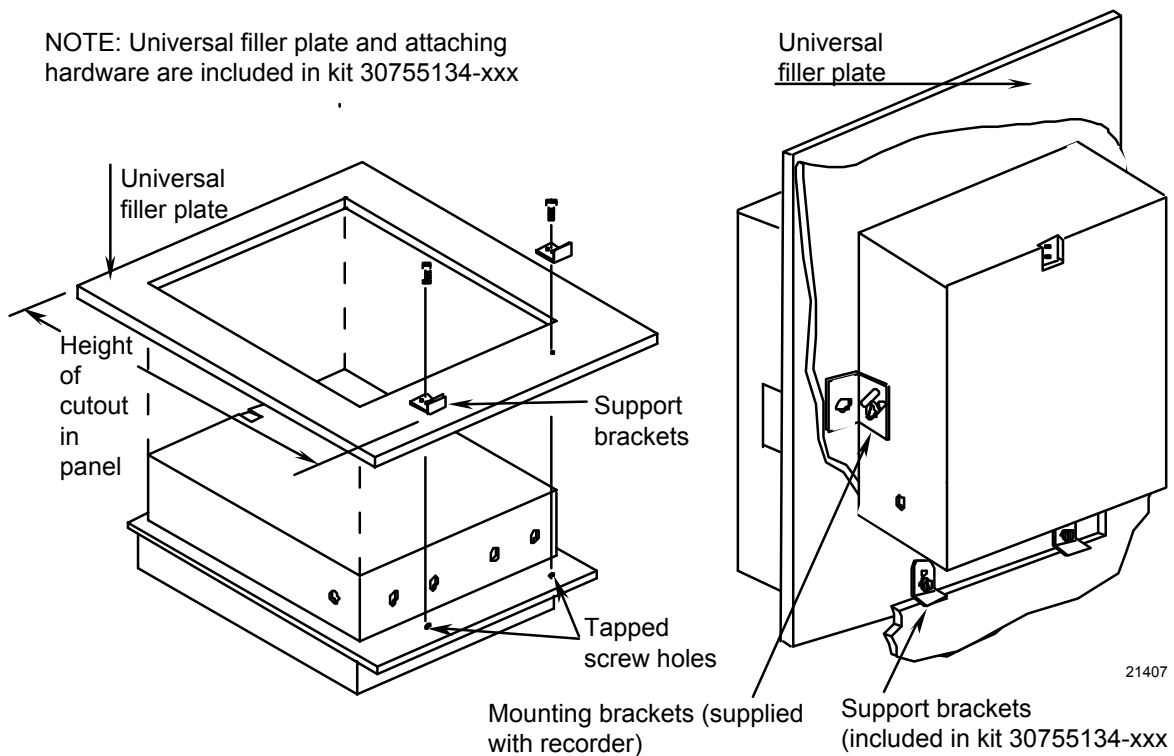


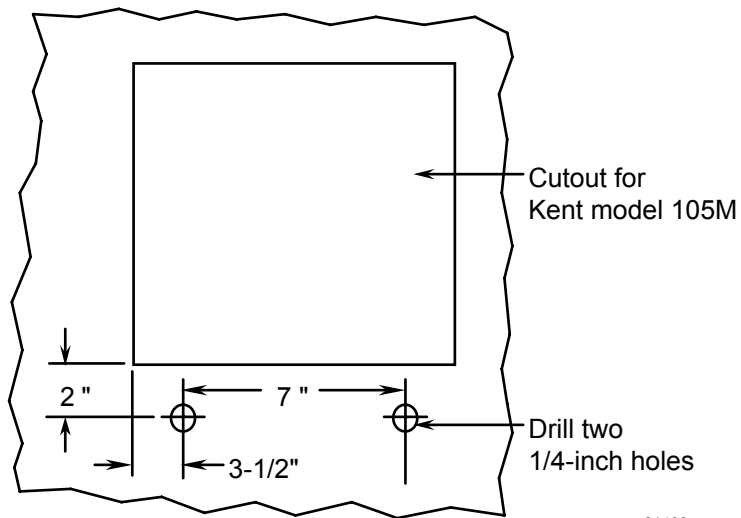
Figure 2-6 Mounting in a panel using universal filler kit

Mounting flush in panel (using cutout made for Kent Model 105M)

Refer to Figure 2-7 and follow the procedure in Table 2-6 to mount your recorder in an existing cutout using the cutout made for Kent Model 105M.

Table 2-6 Mounting flush in a panel using Kent Model 105M cutout

Step	Action
1	Drill two 1/4-inch holes in the back of the panel as shown in Figure 2-7. These holes are for 10-32 screws to be inserted from back of panel into threaded inserts in the back of the recorder case. ATTENTION If the panel is more than 1/4-inch thick, substitute 10-32 x 1/2-inch long screws for the 3/8-inch long screws supplied with the recorder.
2	While supporting the recorder, insert it through the panel cutout and orient the case so that the threaded inserts at the bottom of the case align with the holes drilled in the panel.
3	From the rear of the panel, insert two 10-32 pan head screws of appropriate length into threaded inserts in the recorder case.
4	From the back of the panel, attach a mounting bracket to each side of the recorder case using a 1/4-20 x 1/2-inch hex screw and a lockwasher for each bracket (mounting hardware supplied with recorder). Leave the screws slightly loose so you can adjust the brackets.
5	While holding the recorder firmly against the panel, slide each bracket against the back of the panel and tighten the screws.



21408

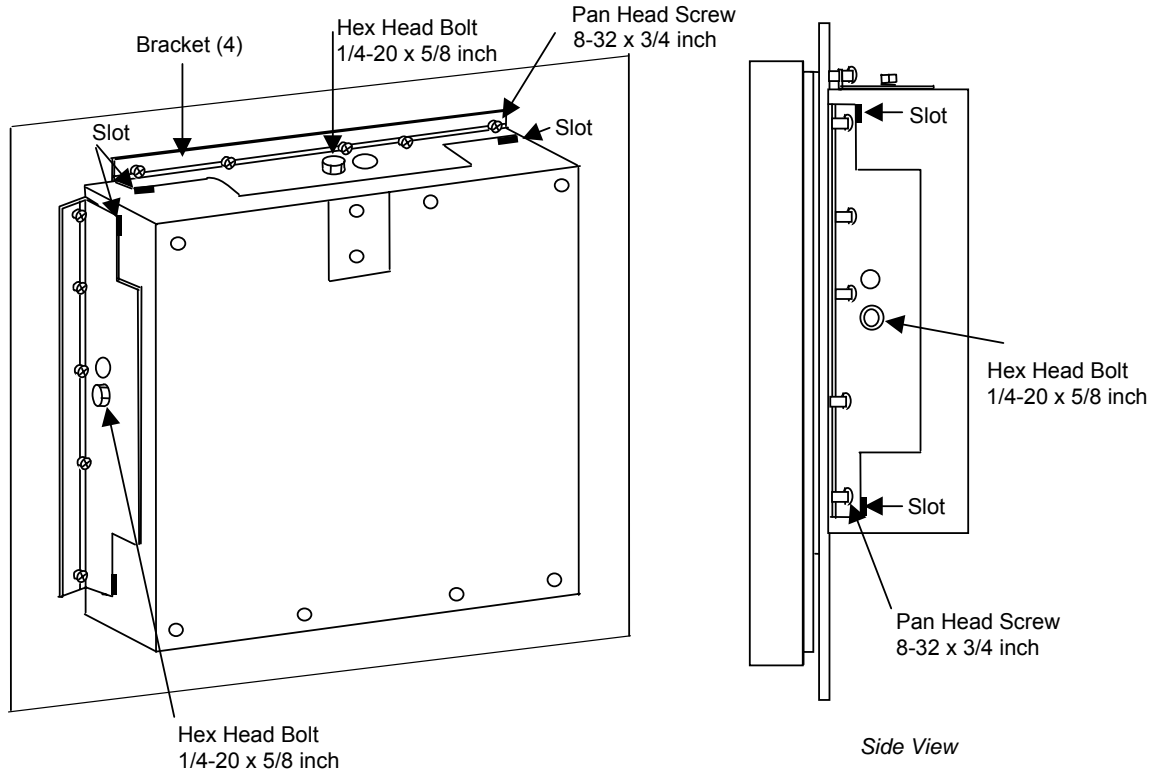
Figure 2-7 Mounting in a panel using Kent Model 105M cutout

Panel mounting recorder with NEMA4X door

Refer to Figure 2-8 and follow the procedure in Table 2-7 to panel mount your recorder if it has a NEMA4X door.

Table 2-7 Procedure for Mounting Recorder with NEMA4X Door

Step	Action
1	Place the panel gasket onto the rear flange of the recorder case.
2	Install five #8-32 x 3/4 screws on each of the four mounting brackets so the ends of the screw threads are flush with the face of the bracket. NOTE: Screw heads to be flange side of brackets.
3	Insert the case with gasket into the panel opening.
4	Position the bracket so that the tabs on the end of the bracket slide into the holes in the case, Secure the four brackets with 1/4-20 x 5/8 long bolts and lockwashers; one to the top, bottom and each side of the case. Tighten the bolts.
5	Start to tighten the #8-32 x 3/4 screws on a bracket. Tighten the end screws first then those toward the middle until all five screws have a 5 to 8 lb-in of torque applied. Do the same to both the other three brackets. When completed all twenty screws should have a 5 to 8 lb-in of torque applied. This assures that the case and panel gaskets are adequately sealed against the panel.



NOTE: Mounting brackets, attaching hardware, and panel gasket are included in kit 30755065-503

Figure 2-8 Panel Mounting Recorder with NEMA4X Door

Mounting on a 2-inch pipe

Refer to Figure 2-9 and follow the procedure in Table 2-8 to mount your recorder on a 2-inch pipe.

Table 2-8 Pipe Mounting Procedure

Step	Action
1	Using the eight plastite screws supplied with the pipe mounting bracket kit, attach the two mounting brackets (flat side against the case) to the back of the recorder. Refer to Figure 2-9 for location.
2	Position the recorder with brackets on the 2-inch pipe.
3	Install the U-bolts around the pipe and through the bracket holes. Secure with lockwashers and hex nuts provided.

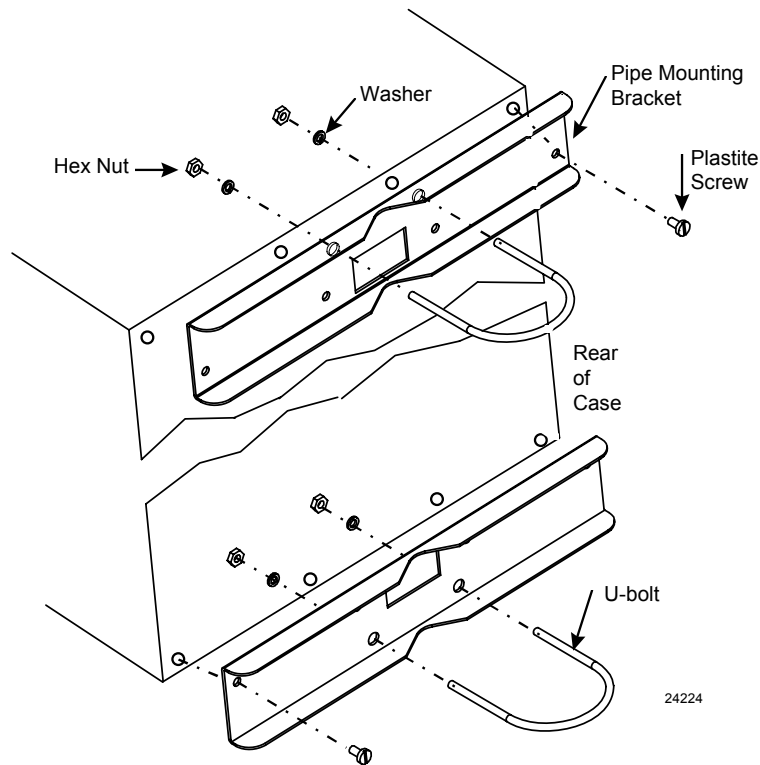


Figure 2-9 Pipe Mounting Brackets

Mounting on surface (of panel or wall)

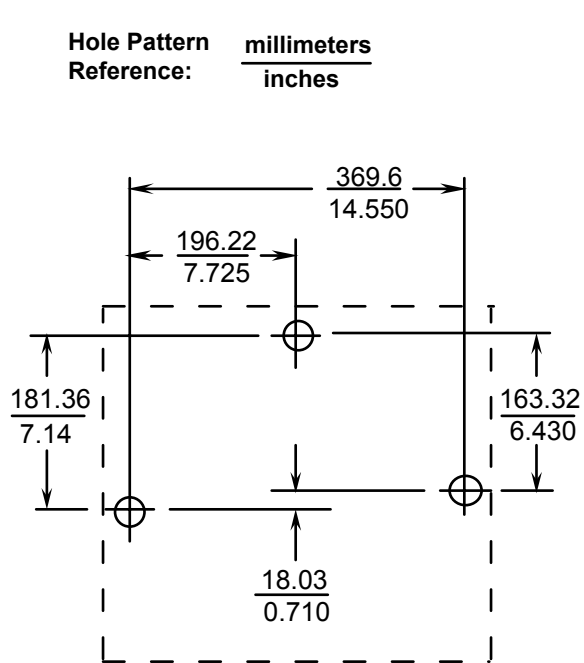
Refer to Figure 2-10 and follow the procedure in Table 2-9 to mount your recorder on a surface (panel or wall).

**ATTENTION**

You must supply three (3) screws for attaching the mounting hardware (brackets and support hook) to panel or wall.

Table 2-9 Mounting flush on a surface (of panel or wall)

Step	Action
1	Using two flat-head 10-32 x 1/4-inch screws supplied with the recorder, fasten the support hook into the recess at the back of the recorder case as shown in Figure 2-10.
2	Using 1/4-20 x 1/2-inch hex screws and lockwashers, attach a mounting bracket to each side of the case. Leave the screws slightly loose so as to permit some adjustments of the brackets.
3	On the panel mark the locations for the three holes as shown by the hole pattern in Figure 2-10.
4	Using a drill of appropriate size for user-supplied screws, drill a hole in the front of the panel for the eye of the support hook.
5	Insert the screws for the support hook into the panel, allowing the screw head to protrude approximately 5/16-inch.
6	Hang the recorder support hook on the screw. Make sure that the locations for the other two holes (marked in step three) are correct. If not, make sure that the recorder is aligned vertically and use the brackets as templates to mark the proper locations.
7	Remove the recorder from the panel and drill the other two holes.
8	Hang the recorder on the screw by the support hook and insert the other two user-supplied screws through the brackets into the panel. Tighten the two hex screws that attach the brackets to the case.



NOTE:

These screws must be supplied by user; all other mounting hardware is supplied with recorder.

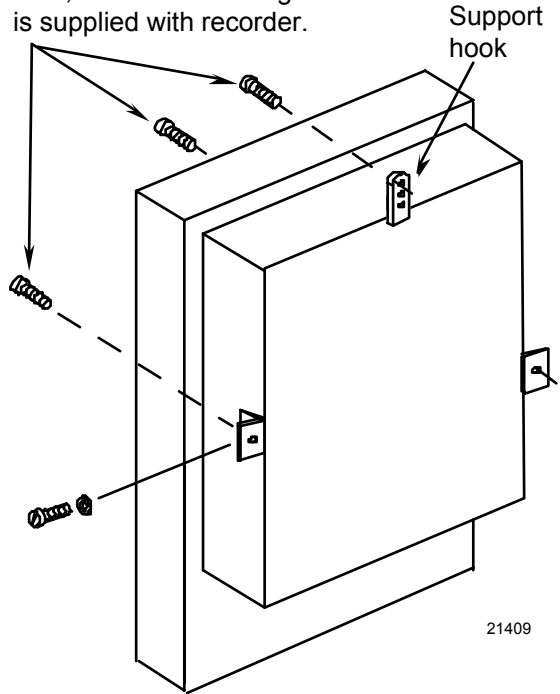


Figure 2-10 Mounting flush on a surface (of panel or wall)

2.5 Wiring Prerequisites

Taking electrical noise precautions

Electrical noise is composed of unabated electrical signals which produce undesirable effects in measurements and control circuits.

Digital equipment is especially sensitive to the effects of electrical noise. Your recorder has built-in circuits to reduce the effect of electrical noise from various sources. If there is a need to further reduce these effects:

- Separate External Wiring - separate connecting wires into bundles (see Table 2-10) and route the individual bundles through separate conduits or metal trays.
- Use Suppression Devices - for additional noise protection, you may want to add suppression devices at the external source; appropriate suppression devices are commercially available.



REFERENCE

For additional noise information, refer to *document number 51-52-05-01*.

Electrical considerations



The recorder is considered “rack and panel mounted equipment” per EN 61010-1, Safety Requirements for Electrical Equipment for Measurement, Control, and Laboratory Use, Part 1: General Requirements.

Recorder grounding



PROTECTIVE BONDING (grounding) of this recorder shall be in accordance with National and local electrical codes.

Functional Earth



To minimize electrical noise and transients that may adversely affect the system, supplementary bonding of the recorder enclosure to a functional earth ground, using a 3/4” braided copper conductor, is required.

A terminal on the rear of the recorder is provided for this connection.

CE conformity special conditions (Europe)

Braid shielded cable is required for all Input I/O and Output Relay cables. All recorder cable shield wires, except the RS485 Modbus communications cable shield, must be connected to a low impedance earth ground at the recorder. This can be done by bussing the shields to an earth ground point, or by connecting the shields to the conduit entry fittings if they are in electrical contact with the enclosure conductive coating. In either case, the shields shall not extend into the recorder enclosure. The cable shields shall also be connected to a low impedance earth ground at the farthest end of the cable, through a 0.0047 μ F capacitor. See each of the individual wiring diagrams.

For the RS485 Modbus communications cable, Alpha XTRA Guard I cable (Alpha P/N 5121C) is required. At the recorder end, the communications cable shield must be unconnected and must not extend into the recorder enclosure. The shield of the communications cable must be connected to earth ground at the farthest end of the cable. See the option wiring procedure for the RS485 Communications Card.

Inside of the enclosure, the user must install ferrite suppression filters and capacitors on all wires connected to the recorder. ©Fair-Rite Products Corp. part number 0443164151, or equivalent, shall be installed as shown in Figure 2-11 to Figure 2-22, one filter for each circuit group.

Cable with an outer jacket diameter larger than 6.7 mm (0.264 in.) may require the outer jacket to be removed to fit the required one turn in the filter, or the selection of a different cable.

Permissible wire bundling

Table 2-10 shows which wire functions should be bundled together.

Table 2-10 Permissible wiring bundling

Bundle No.	Wire Functions
1	<ul style="list-style-type: none">• Line power wiring• Earth ground wiring• Control relay output wiring• Line voltage alarm wiring
2	Analog signal wire, such as: <ul style="list-style-type: none">• Input signal wire (thermocouple, 4 to 20 mA, etc.)• 4-20 mA output signal wiring• Slidewire feedback circuit wiring• Digital input signals• Communications• 4-20 mA auxiliary output
3	<ul style="list-style-type: none">• Low voltage alarm relay output wiring• Low voltage wiring to solid state type control circuits

Identify your wiring requirements

To determine the appropriate diagrams for wiring your recorder, refer to the model number interpretation in this section. The model number of the recorder can be found on the chart plate.

2.6 Input Wiring Procedures

Wiring the recorder

Using the information contained in the model number, select the appropriate wiring diagrams from the figures listed below and wire the recorder accordingly.

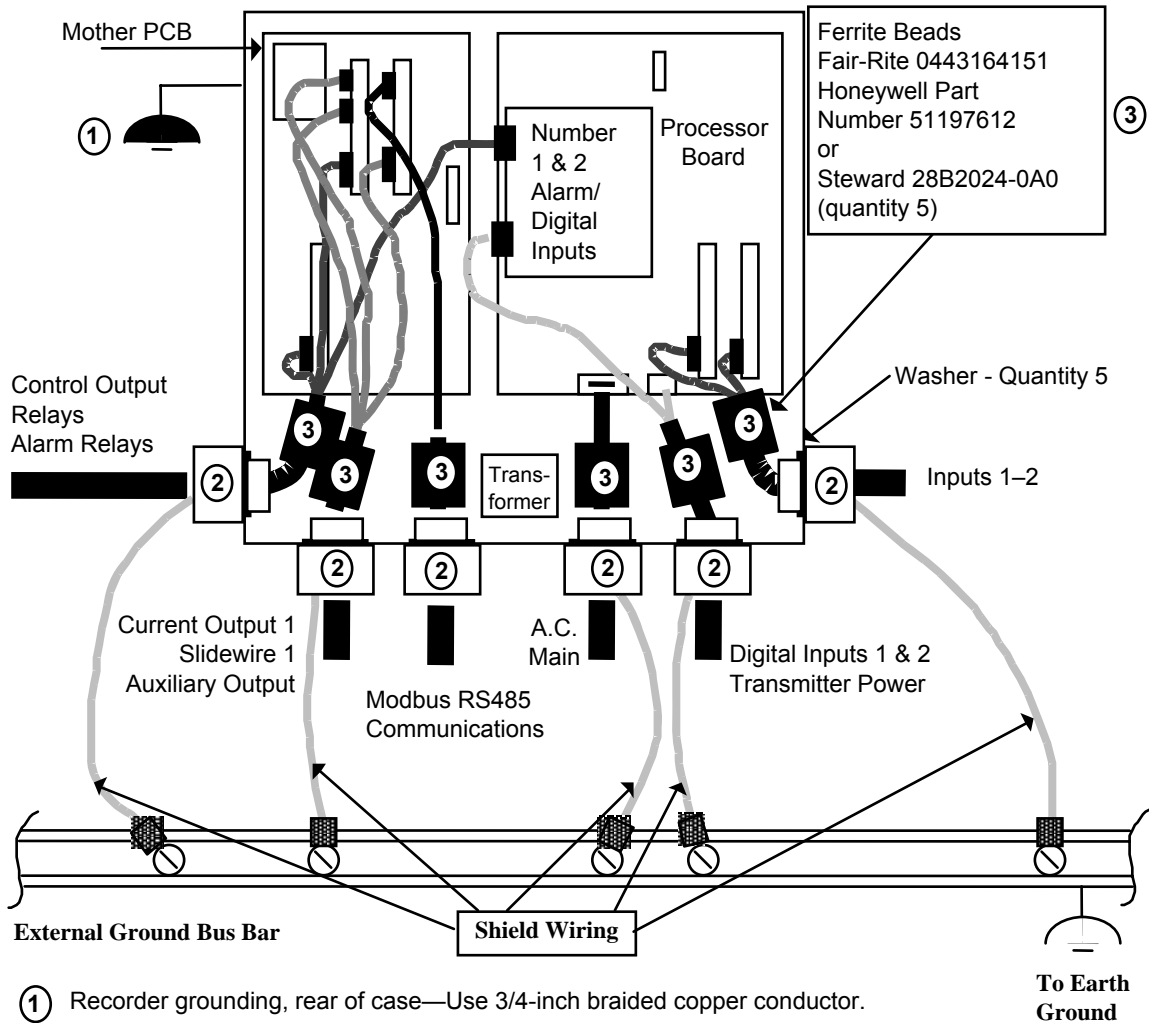
Wiring Requirements	Refer to
Ferrite Filter Locations	Figure 2-11
AC Line Power	Figure 2-12
Thermocouple, RTD, Radiomatic, mV, or 0–5 Vdc Inputs	Figure 2-13
4–20 mA Inputs	Figure 2-14
0–10 Vdc Inputs	Figure 2-15
4–20 mA Current Outputs or Auxiliary Outputs #2 and #3	Figure 2-16
Position Proportional Control Outputs	Figure 2-17
Relay Control Outputs – Time Proportioning	Figure 2-18
Alarm #1 and #2 Outputs and Digital Inputs	Figure 2-19
Alarm Outputs #3, #4, #5, and #6	Figure 2-20
RS485 Modbus Communications	Figure 2-21
Auxiliary Output	Figure 2-22

Ferrite filter locations (CE Mark)

Inside of the enclosure, install ferrite suppression filters on all wires connected to the recorder. ©Fair-Rite Products Corp. part number 0443164151, or equivalent, shall be installed as shown in Figure 2-11, one filter for each circuit group. Cable with an outer jacket diameter larger than 6.7 mm (0.264 in.) may require the outer jacket to be removed to fit the required one turn in the filter, or the selection of a different cable.

Shield Wiring

The shield wires of all cables, except the Modbus RS485 communications cable, should be tied to earth ground at the recorder end and to earth ground through a .0047 μ F Capacitor at the other end of the cable. An example of shield wiring to an external ground bus bar is shown in Figure 2-11.



23128

Figure 2-11 Ferrite filter locations and shield wiring (CE Mark)

AC line power

Refer to Figure 2-12 and follow the procedure in Table 2-11 to connect the AC line power.



WARNING

Be sure that the line voltage is OFF before connecting the power wires to the recorder or personal injury could result.

This equipment is suitable for connection to 120/240 Vac, 50/60 Hz, power supply mains. It is the user's responsibility to provide a switch and non-time delay (North America), quick-acting, high breaking capacity, Type F, (Europe) 1/2 A, 250 V fuse(s) or circuit-breaker as part of the installation. The switch or

circuit-breaker shall be located in close proximity to the recorder, within easy reach of the OPERATOR. The switch or circuit-breaker shall be marked as the disconnecting device for the recorder.

Table 2-11 AC line power wiring

Step	Action
1	Open the recorder door. Loosen the captive screw in the chart plate and swing the plate out.
2	Locate connector J10 on the bottom edge of the main printed circuit board. (Refer to Figure 2-12.)
3	Remove the unwired plug from J10.
4	Run the power wires separately through second conduit from the right.
5	For CE Mark conformity, install the ferrite filter as shown in Figure 2-11.
6	Strip insulation from the end of each wire.
7	Loosen the screws in plug J10 terminals and position the plug as you would to plug it into J10.
8	<p>Insert</p> <ul style="list-style-type: none"> • the green wire (G) into the first screw clamp from the right, • the white wire (L2) into the second screw clamp from the right, and • the black wire (L1) into the third screw clamp from the right. <p>Tighten the screws to secure the wires.</p> <p>CAUTION To avoid damaging the recorder, be sure that you install the power wires into the correct screw clamps. Make sure the fuse block is installed properly for the given supply rating — 120 or 240 Vac. The fuse is in the 120 Vac location from the factory.</p>
9	<p>Make sure the fuse block is installed in the proper location. Refer to Figure 2-12 for fuse block location.</p> <ul style="list-style-type: none"> • 120 Vac – Fuse block in location F2 • 240 Vac – Fuse block in location F1
10	<p>Dress the wires as slack as possible. This keeps the noise signal on these wires from bypassing built-in suppression. Also, do not bundle any low level signal wires with the power wires. Refer to Table 2-10 for permissible wire bundling.</p> <ul style="list-style-type: none"> • Refer to document 51-52-05-01 for additional information concerning noise interference prevention.
11	<p>Insert the wired plug into J10.</p> <p>WARNING Input line voltage will be present on the instrument ground plane if safety ground is not attached; personal injury and product damage could result.</p>

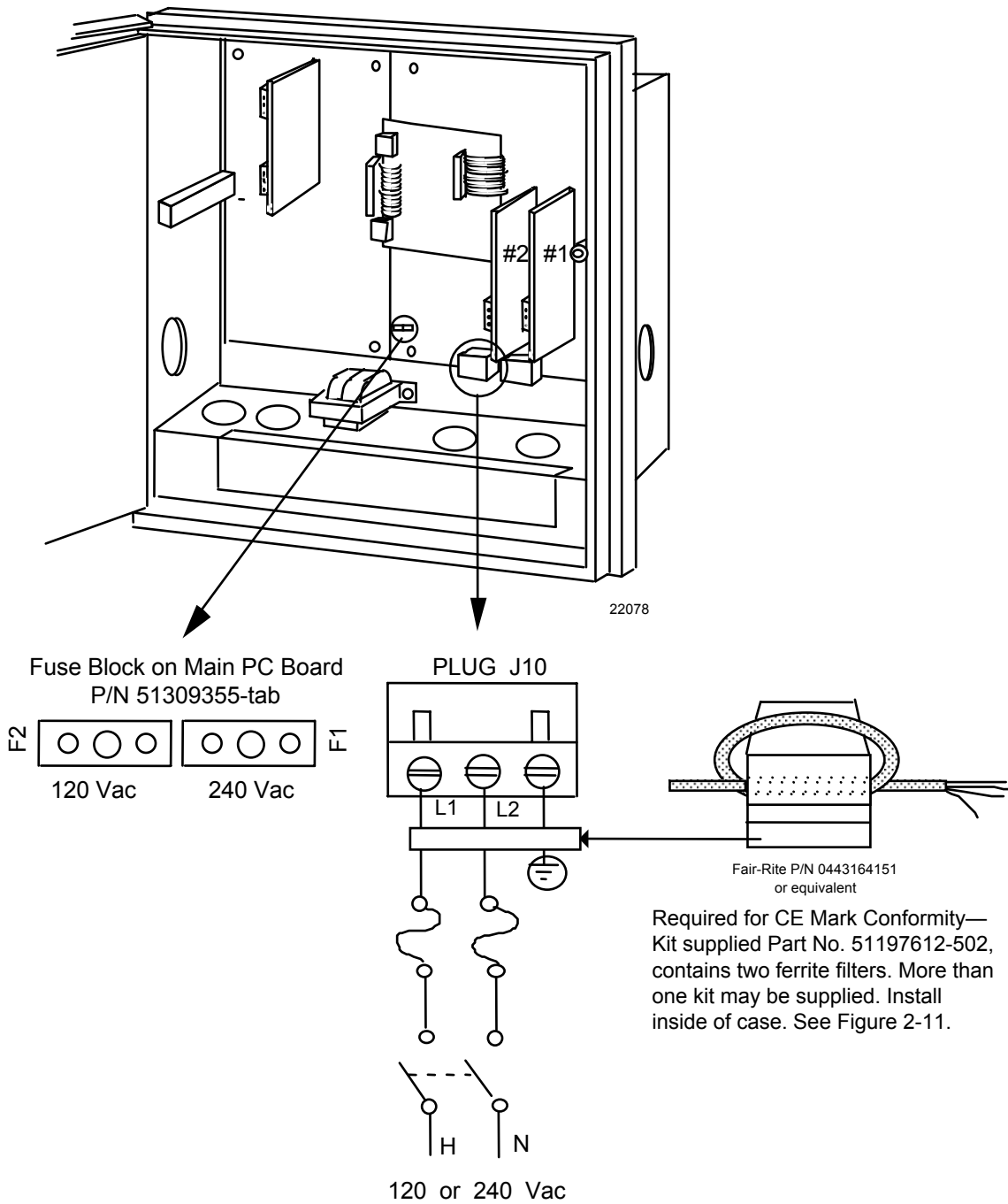


Figure 2-12 AC line power wiring

Thermocouple, RTD, Radiamatic, mV, or 0-5 Vdc inputs

You can wire input 1 or 2 for thermocouple, RTD, Radiamatic, mV, or 0-5 Vdc actuations.

The polarity for inputs #1 and #2 is identical.

The prerequisites are:

- Model Number - Table 1 = 1X00, X100



ATTENTION

For thermocouple or RTD inputs, calibrate the recorder to achieve the stated accuracy. Refer to *Section 7 – Input Calibration*

Refer to Figure 2-13 and follow the procedure in Table 2-12 to wire Thermocouple, RTD, Radiamatic, mV, or 0–5 Vdc inputs.

Table 2-12 Thermocouple, RTD, Radiamatic, mV, or 0–5 Vdc input wiring

Step	Action
1	Open the recorder door. Loosen the captive screw in the chart plate and swing the plate out.
2	Locate connector J2 on the printed circuit board for input 1 (refer to Figure 2-13).
3	Remove the unwired plug from J2.
4	Run the input wires through the desired knockout - DO NOT bundle them with the power wires.
5	For CE Mark conformity: <ul style="list-style-type: none"> • Install the ferrite filter as shown in Figure 2-11. • Install a .01µF capacitor across the J2 terminals and a .0047 µF capacitor at the sensor end of the input wiring as shown in Figure 2-13.
6	Locate jumper position MA/W1 and make sure the jumper is in the W1 position. (See Figure 2-13 for the jumper positions.)
7	Locate jumper position W3 and make sure the jumper is in the proper position for your input type. (See Figure 2-13 for the jumper positions.)
8	Strip insulation from the end of each wire.
9	Loosen the screws in plug J2 terminals and position the plug as you would to plug it into J2.
10	Insert the wires into the appropriate screw clamps for the applicable input type. See Figure 2-13 for specific input actuation plug wiring. Tighten the screws to secure the wires.
11	Insert the wired plug into J2.
12	Repeat steps 2 through 11 for input 2 printed circuit board as applicable.

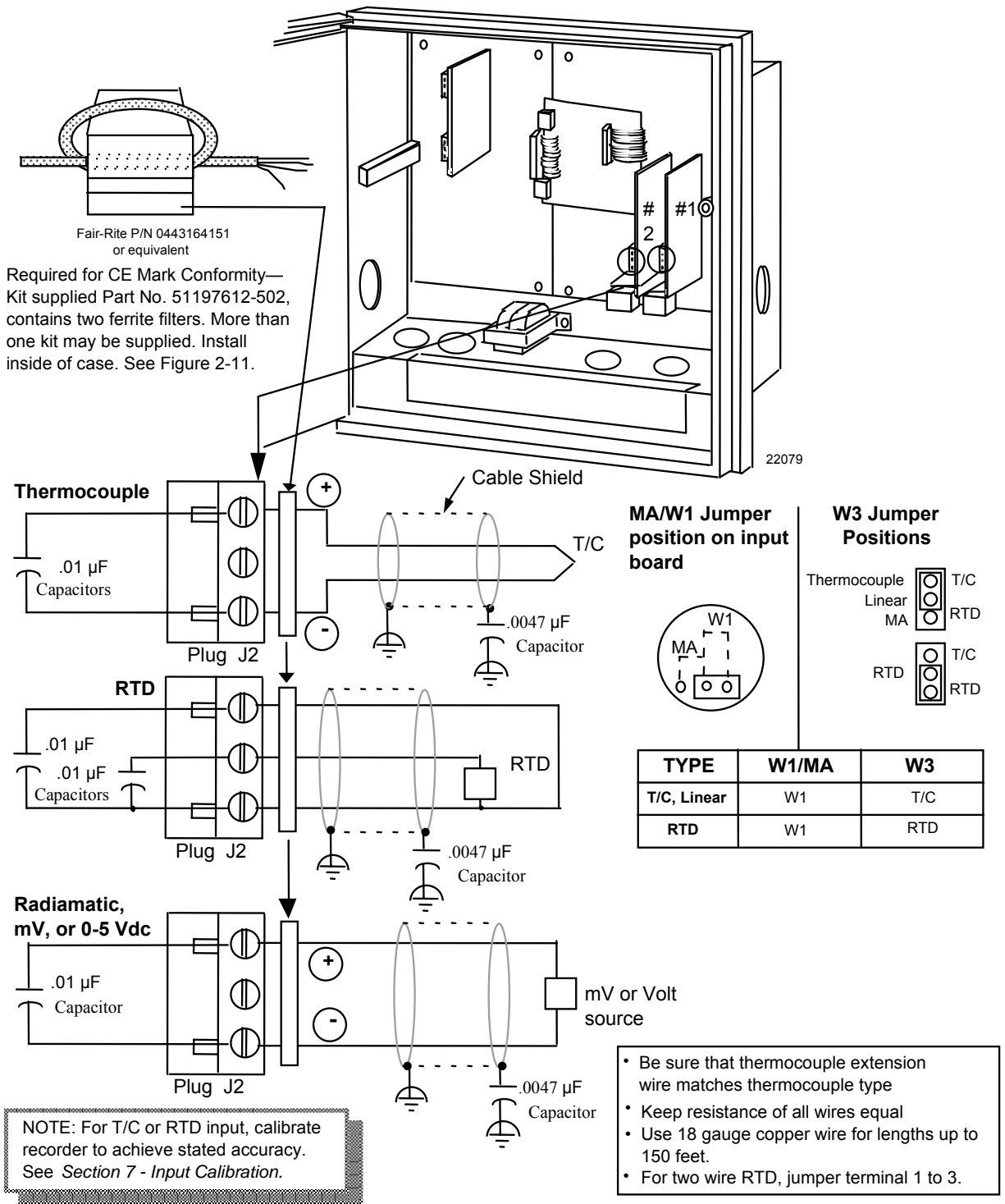


Figure 2-13 Thermocouple, RTD, Radiomatic, mV, or 0-5 Vdc input wiring

4-20 mA inputs and transmitter power

You can wire input 1 or 2 for 4–20 mA actuations.

The polarity for inputs #1 and #2 is identical.

The prerequisites are:

- Model Number - Table 1 = 1X00, X100



ATTENTION

Connector J11 on the main processor printed circuit board can be used to provide 24 Vdc power to up to two field transmitters (without power) which are supplying the 4–20 mA input signals to the recorder (1.2W @ 24 Vdc = 50 mA available).

Refer to Figure 2-14 and follow the procedure in Table 2-13 to wire 4-20 mA inputs.

Table 2-13 4-20 mA input wiring

Step	Action
1	Open the recorder door. Loosen the captive screw in the chart plate and swing the plate out.
2	Be sure that the jumper MA/W1 is installed in the position labeled “MA”; this connects an internal 250-ohm resistor across the 4-20 mA input terminals on J2. (Refer to Figure 2-14 for location of jumper.)
3	Locate jumper W3 and make sure the jumper is in the proper position for your input type (see Figure 2-14).
4	Locate connector J2 on the printed circuit board for input 1 (refer to Figure 2-14).
5	Remove the unwired plug from J2.
6	Run the input wires through the desired knockout - DO NOT bundle them with the power wires.
7	For CE Mark conformity: <ul style="list-style-type: none"> • Install the ferrite filter as shown in Figure 2-11. • Install the capacitors as shown in Figure 2-14.
8	Strip insulation from the end of each wire.
9	Loosen the screws in plug J2 terminals and position the plug as you would to plug it into J2.
10	<ul style="list-style-type: none"> • <i>For transmitters with power:</i> Insert the wires into the appropriate screw clamps and tighten the screws to secure the wires. • <i>For transmitters which require power:</i> Remove the unwired plug from J11 then wire the transmitter power to J11 and the input to J2. Tighten the screws in the plugs to secure the wires.
11	Insert the wired plug into J2 and J11 as applicable.
12	Repeat steps 2 through 11 for input 2 printed circuit board as applicable.

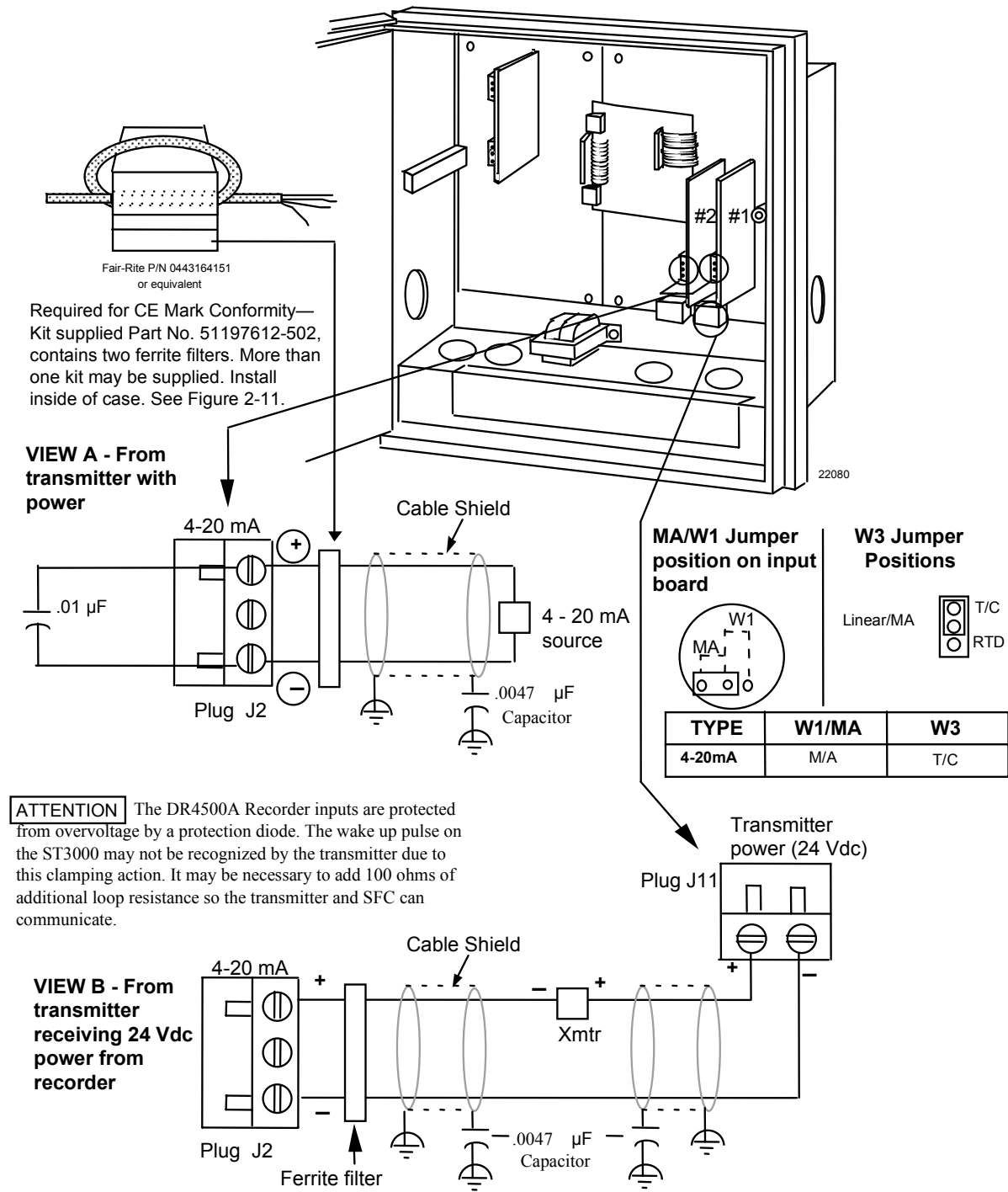


Figure 2-14 4-20 mA input wiring

0-10 Volt dc inputs

You can wire input 1 or 2 for 0–10 Volt dc actuations.

The polarity for inputs #1 and #2 is identical.

The prerequisites are:

- Model Number - Table 1 = 3X00, X300



ATTENTION

Calibrate the recorder to achieve the stated accuracy. Refer to *Section 7 – Input Calibration*.

Refer to Figure 2-15 and follow the procedure in Table 2-14 to wire 0-10 Vdc inputs.

Table 2-14 0-10 Volt dc input wiring

Step	Action
1	Open the recorder door. Loosen the captive screw in the chart plate and swing the plate out.
2	Locate connector J2 on the printed circuit board for input 1 (refer to Figure 2-15).
3	Remove the unwired plug from J2 and replace it with the modified 4-screw plug from the bag of accessories supplied with the recorder.
4	Run the input wires through the desired knockout—DO NOT bundle them with the power wires.
5	For CE Mark conformity: <ul style="list-style-type: none"> • Install the ferrite filter as shown in Figure 2-11. • Install the .01μF capacitor and the .0047μF capacitor as shown in Figure 2-15.
6	Strip insulation from the end of each wire.
7	Loosen the screws in plug J2 terminals and position the plug as you would to plug it into J2.
8	Using the 30755232-002, 100K-ohm, voltage divider connector kit supplied in the bag of accessories, insert the wires into the appropriate screw clamps. Tighten the screws to secure the wires.
9	Install the wired plug into J2. Since J2 has only three receptacles, one of the modified plug connectors is designed to slide outside J2 when the plug is installed.
10	Locate jumper position W3 and make sure the jumper is in the proper position for your input type. (See Figure 2-15 for the location.)
11	Locate jumper position MA/W1 and make sure the jumper is in the W1 position. (See Figure 2-15 for the location.)
12	Repeat steps 2 through 11 for input 2 printed circuit board as applicable.

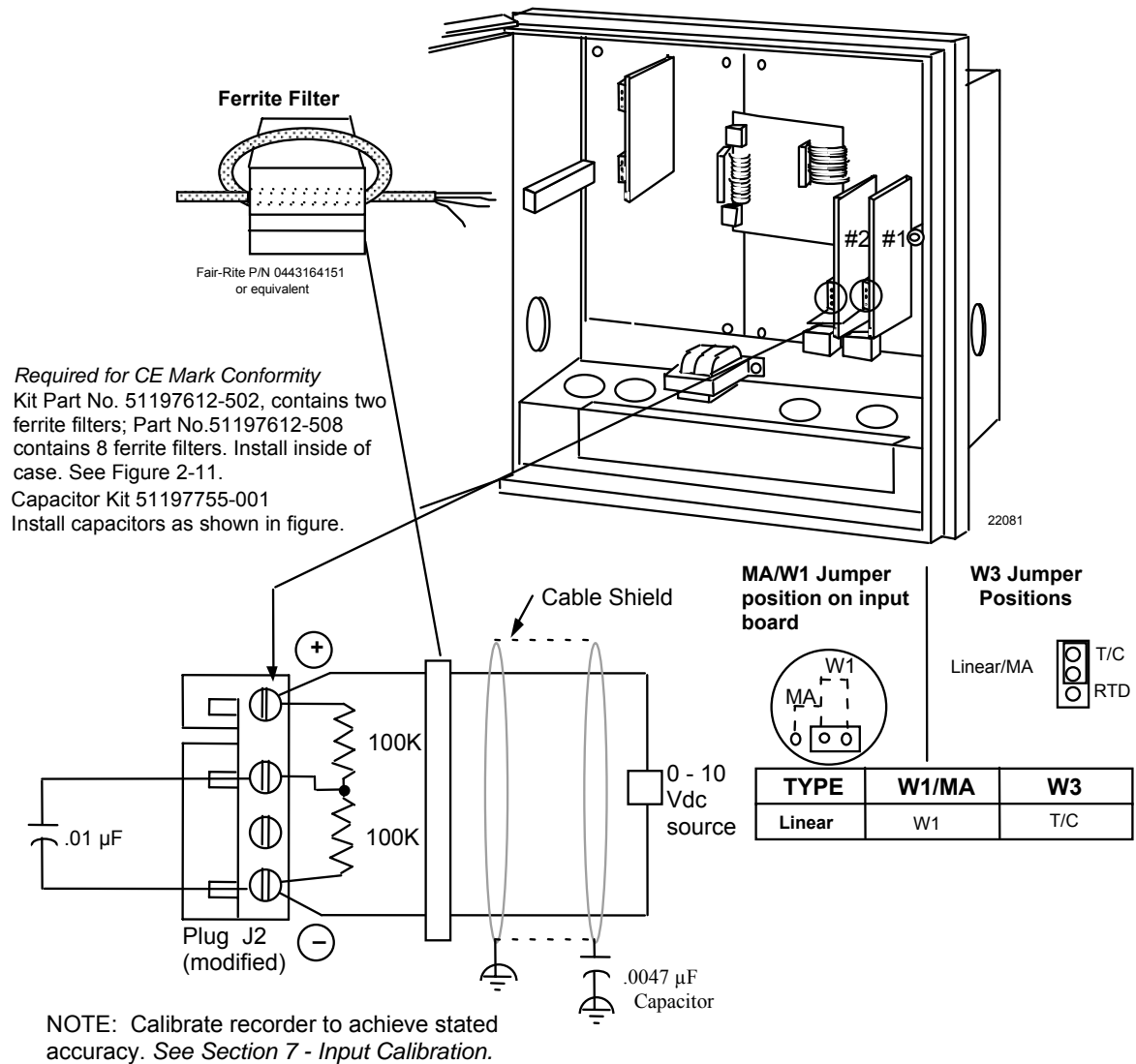


Figure 2-15 0-10 Volt dc input wiring

2.7 Output Wiring Procedures

4-20 mA control output wiring

You can wire control output 1 or 2 for 4-20 mA output.

The prerequisites are:

- Model Number - Table 2 = 1X, 6X, X1, X6

Refer to Figure 2-16 and follow the procedure in Table 2-15 to wire 4-20 mA control outputs.

Table 2-15 4-20 mA control output wiring

Step	Action
1	Open the recorder door. Loosen the captive screw in the chart plate and swing the plate out.
2	Locate connector J1 near the top of the control output #1 printed circuit board (refer to Figure 2-16 for location).
3	Remove the unwired plug from J1.
4	Run the output wires through the desired knockout.
5	For CE Mark conformity: <ul style="list-style-type: none"> • Install the ferrite filter as shown in Figure 2-11. • Install the .0047μF capacitor as shown in Figure 2-16.
6	Strip insulation from the end of each wire.
7	Loosen the screws in plug J1 terminals and position the plug as you would to plug it into J1.
8	Observing the polarity, insert the wires into the appropriate screw clamps as shown (refer to Figure 2-16). Tighten the screws to secure the wires.
9	Install the wired plug into J1.
10	Locate jumper position W6/W7 on the bottom left portion of the board. Make sure W7 position is selected for 4-20 mA output.
11	Repeat steps 2 through 10 for control output #2 printed circuit board as applicable.



ATTENTION

Be sure that the 4-20 mA current output is aligned. Refer to *subsection 8.2 Current Proportional Output Calibration*.



TIP

The 4-20 mA output can be used as a retransmission output if it is not used as a control output.

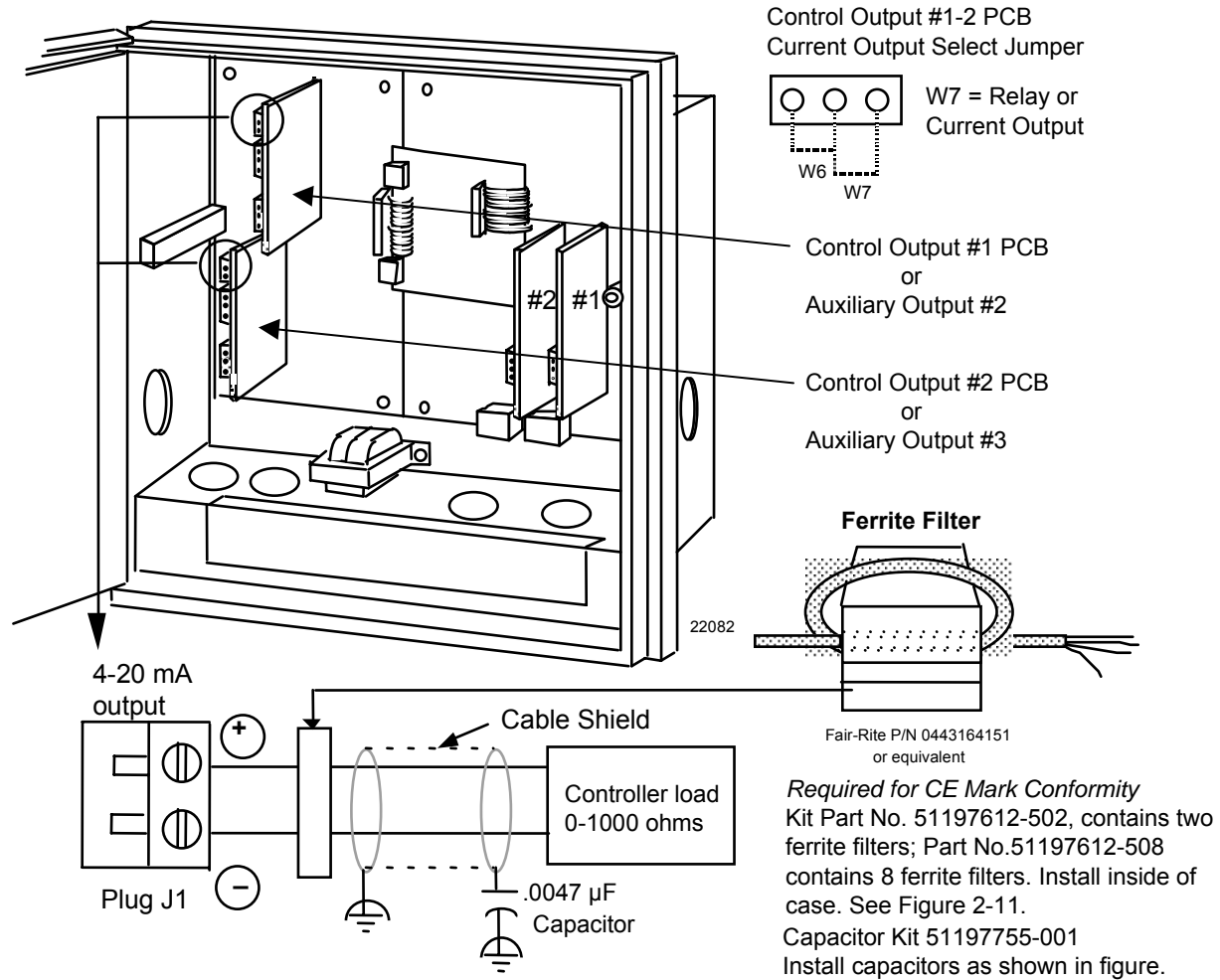


Figure 2-16 4-20 mA control output wiring (or Aux Out #2 and #3 wiring)

Position proportional control output wiring

You can wire control output 1 or 2 for position proportional output.

The prerequisites are:

- Model Number - Table 2 = 10 or 11

Refer to Figure 2-17 and follow the procedure in Table 2-16 to wire position proportional control output.



ATTENTION

Be sure to calibrate the position proportional control output so that the increase and decrease relays operate properly with respect to the position of the external feedback slidewire. Refer to *Section 8 - Output Calibration* in this manual.

Table 2-16 Position proportional control output wiring

Step	Action
1	Open the recorder door. Loosen the captive screw in the chart plate and swing the plate out.
2	Locate connector J2 and J5 on the control output #1 printed circuit board (refer to Figure 2-17 for location) and remove the unwired plug from J2 and J5.
3	Locate jumper positions W2/W3 and W4/W5 below connector J5 on the printed circuit board. Remove plug-in output #1 printed circuit board for better access to the jumpers. Be sure to tag and remove all the plug connections to the printed circuit board before removing it. Position the jumpers as shown in Figure 2-17 for desired relay contact action. Locate jumper position W6/W7 on the bottom left portion of the board. Make sure position W6 is selected for position proportioning, then reinstall the printed circuit board.
4	Run the feedback slidewire and motor drive wires through the desired knockouts.
5	For CE Mark conformity: <ul style="list-style-type: none"> • install the ferrite filter as shown in Figure 2-11 • install the shield capacitors as shown in Figure 2-17.
6	Strip insulation from the end of each wire.
7	Loosen the screws in plug J2 terminals and position the plug as you would to plug it into J2.
8	Insert the wires from the motor's feedback slidewire into the appropriate screw clamps as shown (refer to Figure 2-17). Tighten the screws to secure the wires.
9	Loosen the screws in plug J5 terminals and position the plug as you would to plug it into J5.
10	Insert the wires for the motor into the appropriate screw clamps as shown (refer to Figure 2-17). Tighten the screws to secure the wires.
11	Install the wired plug into J2 and J5, as applicable.
12	Repeat steps 2 through 11 for Control Output #2 printed circuit board as applicable.

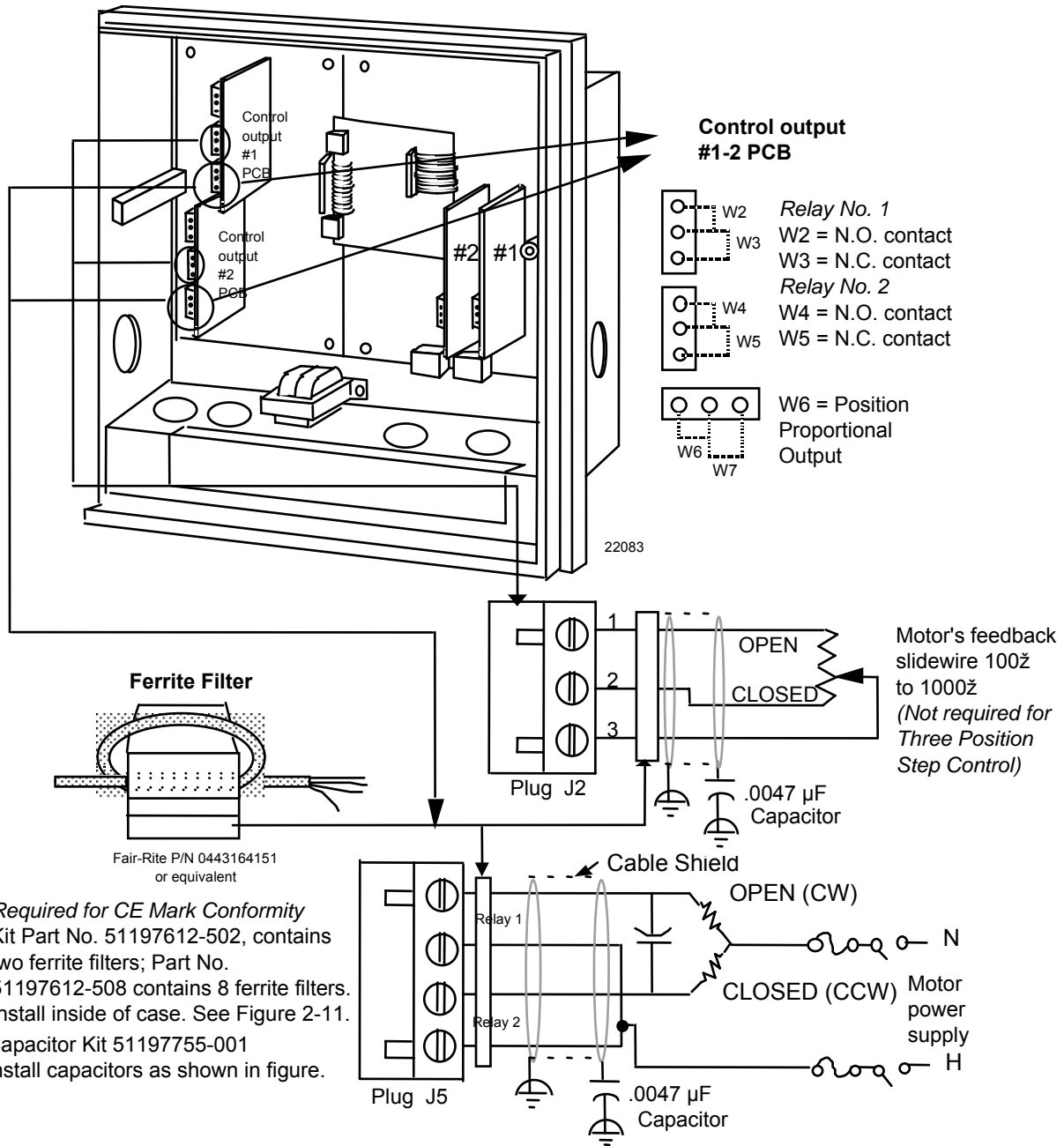


Figure 2-17 Position proportional control output wiring

Relay control output wiring

You can wire control output 1 or 2 for relay output including Time proportional applications.

The prerequisites are:

- Model Number - Table 2 = 1X or X1

Refer to Figure 2-18 and follow the procedure in Table 2-17 to wire relay control outputs.

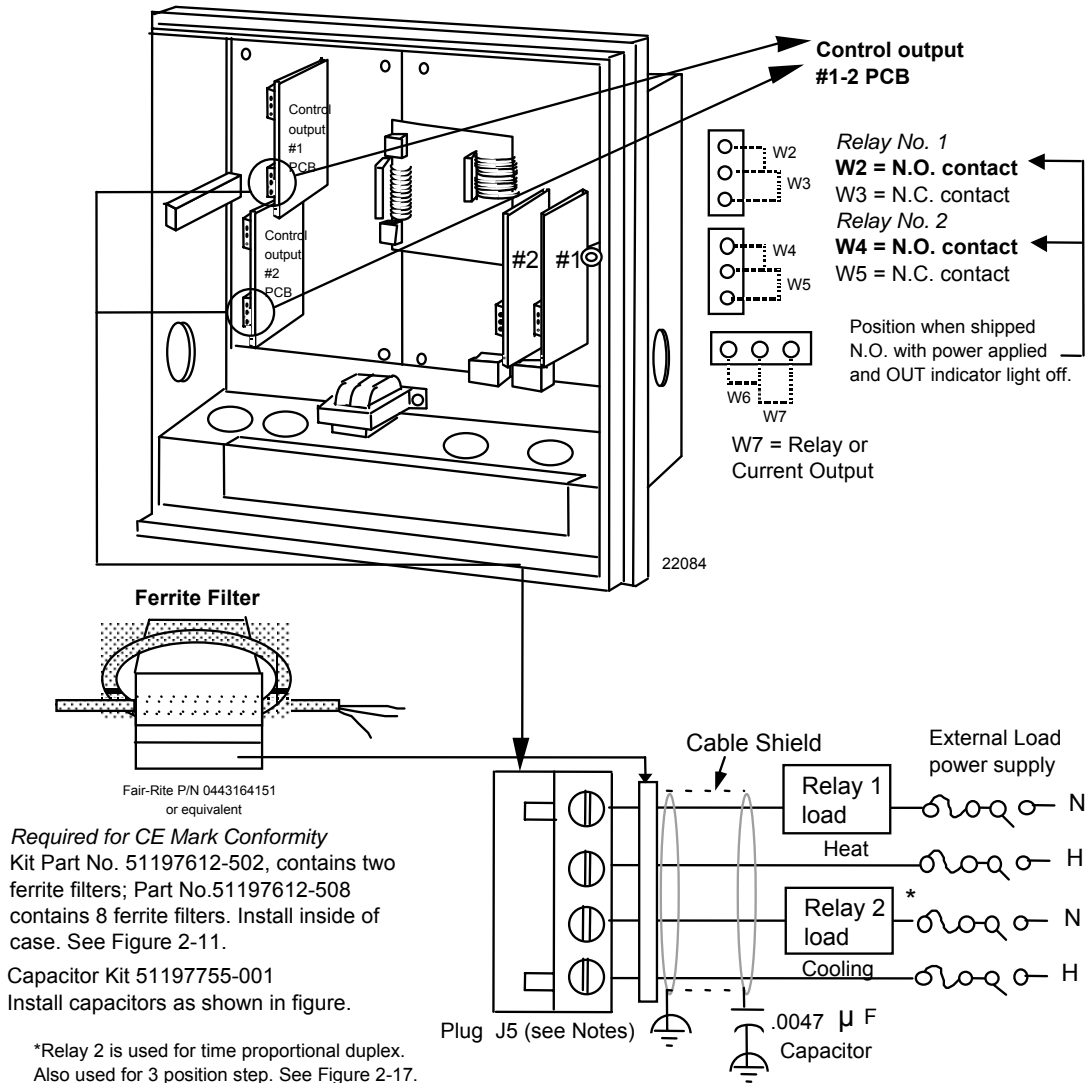


ATTENTION

Relay #2 is used for time proportional control.

Table 2-17 Relay control output wiring

Step	Action
1	Open the recorder door. Loosen the captive screw in the chart plate and swing the plate out.
2	Locate connector J5 on the control output #1 printed circuit board (refer to Figure 2-18 for location).
3	Remove the unwired plug from J5.
4	Locate jumper positions W2/W3 and W4/W5 below connector J5 on the printed circuit board. Remove plug-in output #1 printed circuit board for better access to the jumpers. Be sure to tag and remove all the plug connections to the printed circuit board before removing it. Position the jumpers as shown in Figure 2-18 for desired relay contact action. Locate jumper position W6/W7 on the bottom left portion of the board. Make sure W7 position is selected for relay control output, then reinstall the printed circuit board.
5	Run the relay load wires through the desired knockouts.
6	For CE Mark conformity: <ul style="list-style-type: none"> • Install the ferrite filter as shown in Figure 2-11. • Install the shield capacitor as shown in Figure 2-18.
7	Strip insulation from the end of each wire.
8	Loosen the screws in plug J5 terminals and position the plug as you would to plug it into J5.
9	Insert the relay wires and relay power into the appropriate screw clamps for single or duplex action as shown (refer to Figure 2-18); tighten the screws to secure the wires.
10	Install the wired plug into J5.
11	Repeat steps 2 through 10 for control output #2 printed circuit board as applicable.



Notes:

1. J5 terminals 2 and 4 are the non-switched connections to an SPST relay. Selectable for normally open or normally closed as required.
2. This relay supplies a dry contact closure. User must supply appropriate power connections for his external device.
3. This relay has a resistive load rating of 5A @ 120 Vac. Load calculation example:

$$\frac{\text{Supply voltage (for example: 115 Vac)}}{\text{Resistance of customer controlled device}} = \text{must equal a number less than 5 amps}$$

Figure 2-18 Relay control output wiring

2.8 Option Wiring Procedures

Alarm output and digital input wiring

You can wire #1 and #2 Alarm Outputs and Digital Inputs.

The prerequisites are:

- Model Number - Table 3 = XX1

Refer to Figure 2-19 and follow the procedure in Table 2-18 to wire alarm outputs or digital inputs.

The alarm output is a dry contact closure.

Table 2-18 Alarm output or digital input wiring

Step	Action
1	Open the recorder door. Loosen the captive screw in the chart plate and swing the plate out.
2	Locate connector J3 and J4 on the alarm output/digital input printed circuit board (refer to Figure 2-19 for location).
3	Remove the unwired plug from J3.
4	Run the digital input wires through the desired knockout.
5	For CE Mark conformity, install the ferrite filter as shown in Figure 2-11.
6	Strip insulation from the end of each wire.
7	Loosen the screws in plug J3 terminals and position the plug as you would to plug it into J3.
8	Insert the wires for the digital inputs into the appropriate screw clamps as shown (refer to Figure 2-19). Note that you can wire the contacts in an and /or fashion, so that both contacts or either contact initiates the configured action. Tighten the screws to secure the wires.
9	Install the wired plug into J3.
10	Remove the unwired plug from J4.
11	Run the alarm output wires through the desired knockout.
12	For CE Mark conformity: <ul style="list-style-type: none"> • install the ferrite filter as shown in Figure 2-11 • install the shield capacitors as shown in Figure 2-19.
13	Strip insulation from the end of each wire.
14	Loosen the screws in plug J4 terminals and position the plug as you would to plug it into J4.
15	Insert the wires for the alarm devices into the appropriate screw clamps as shown (refer to Figure 2-19). Tighten the screws to secure the wires.
16	Locate the jumper positions W1/W2 and W3/W4 on the printed circuit board. Reposition the jumpers as shown in Figure 2-19 for the desired relay control action. The recorder is shipped with the W1 and W3 in N.C. positions.
17	Install the wired plug into J4.

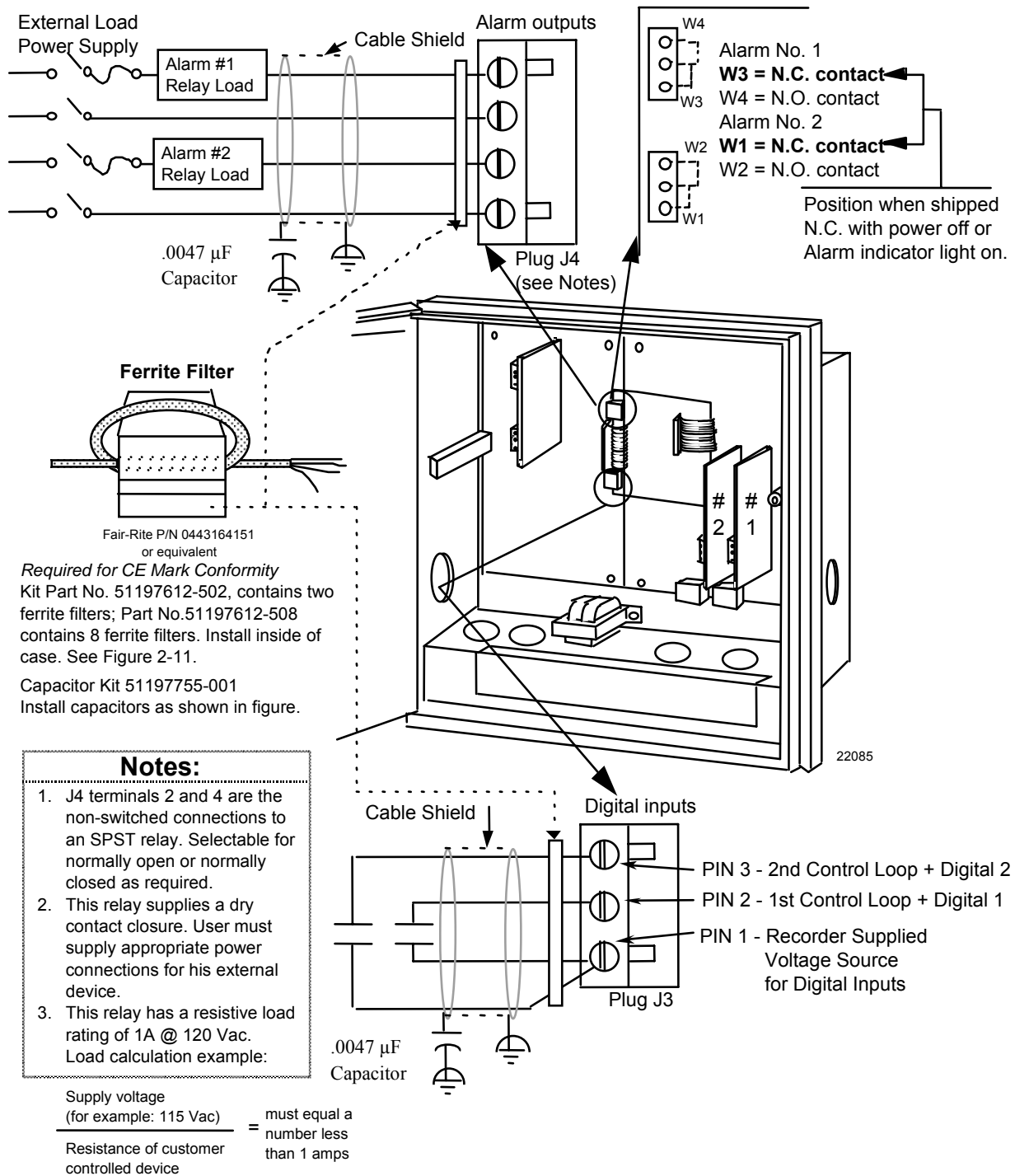


Figure 2-19 Alarm output or digital input wiring

Additional alarm wiring information

The DR4500 has the ability to provide for Alarm outputs 3, 4, 5, and 6.

Follow the procedures listed below to wire No. 3 and No. 4 Alarm Outputs and No. 5 and No. 6 Alarm Outputs.

Alarms 3 and 4 output wiring

You can wire #3 and #4 Alarm Outputs.

The prerequisites are:

- Model Number - Model Table 2 = 1X, 6X*

**If control output is 4-20 mA, then the relays on the control card are available for use as alarms.*

Refer to Figure 2-20 and follow the procedure in Table 2-19 to wire Alarm 3 and Alarm 4 outputs.

Table 2-19 Alarm 3 and Alarm 4 output wiring

Step	Action
1	Open the recorder door. Loosen the captive screw in the chart plate and swing the plate out.
2	Locate connector J5 on the 4-20 mA control output printed circuit board to wire relays #3 and #4. Refer to Figure 2-20 for location.
3	Remove the unwired plug from J5.
4	Locate jumper position W2/W3 and W4/W5 below connector J5 on the printed circuit board. Note that you may want to remove the plug-in output printed circuit board for better access to jumpers. Be sure to tag and remove all the plug connections to the printed circuit boards before removing it. Position the jumpers as shown for the desired relay contact action and reinstall the printed circuit board.
5	Run the alarm output wires through the desired knockout.
6	For CE Mark conformity: <ul style="list-style-type: none"> • Install the ferrite filter as shown in Figure 2-11. • Install the capacitors as shown in Figure 2-20.
7	Strip insulation from the end of each wire.
8	Loosen the screws in plug J5 terminals and position the plug as you would to plug it into J5.
9	Insert the wires for the alarm devices into the appropriate screw clamps as shown. Refer to Figure 2-20. Tighten the screws to secure the wires.
10	Install the wired plug into J5.

Alarm 5 and 6 output wiring

You can wire #5 and #6 Alarm outputs.

The prerequisites are:

- Model Key Number = DR45A2
- Model Number - Model Table 2 = X1, X6*

**If control output is 4-20 mA, then the relays on the control card are available for use as alarms.*

Refer to Figure 2-20 and follow the procedure in Table 2-20 to wire Alarm 5 and Alarm 6 outputs.

Table 2-20 Alarm 5 and Alarm 6 output wiring

Step	Action
1	Open the recorder door. Loosen the captive screw in the chart plate and swing the plate out.
2	Locate connector J5 on the 4-20 mA control output printed circuit board to wire relays #5 and #6. Refer to Figure 2-20 for location.
3	Remove the unwired plug from J5.
4	Locate jumper position W2/W3 and W4/W5 below connector J5 on the printed circuit board. Note that you may want to remove the plug-in output printed circuit board for better access to jumpers. Be sure to tag and remove all the plug connections to the printed circuit boards before removing it. Position the jumpers as shown for the desired relay contact action and reinstall the printed circuit board.
5	Run the Alarm output wires through the desired knockout.
6	For CE Mark conformity: <ul style="list-style-type: none"> • Install the ferrite filter as shown in Figure 2-11. • Install the capacitors as shown in Figure 2-20.
7	Strip insulation from the end of each wire.
8	Loosen the screws in plug J5 terminals and position the plug as you would to plug it into J5.
9	Insert the wires for the alarm devices into the appropriate screw clamps as shown. Refer to Figure 2-20. Tighten the screws to secure the wires.
10	Install the wired plug into J5.

Wiring for alarm outputs #3, 4, 5, and 6

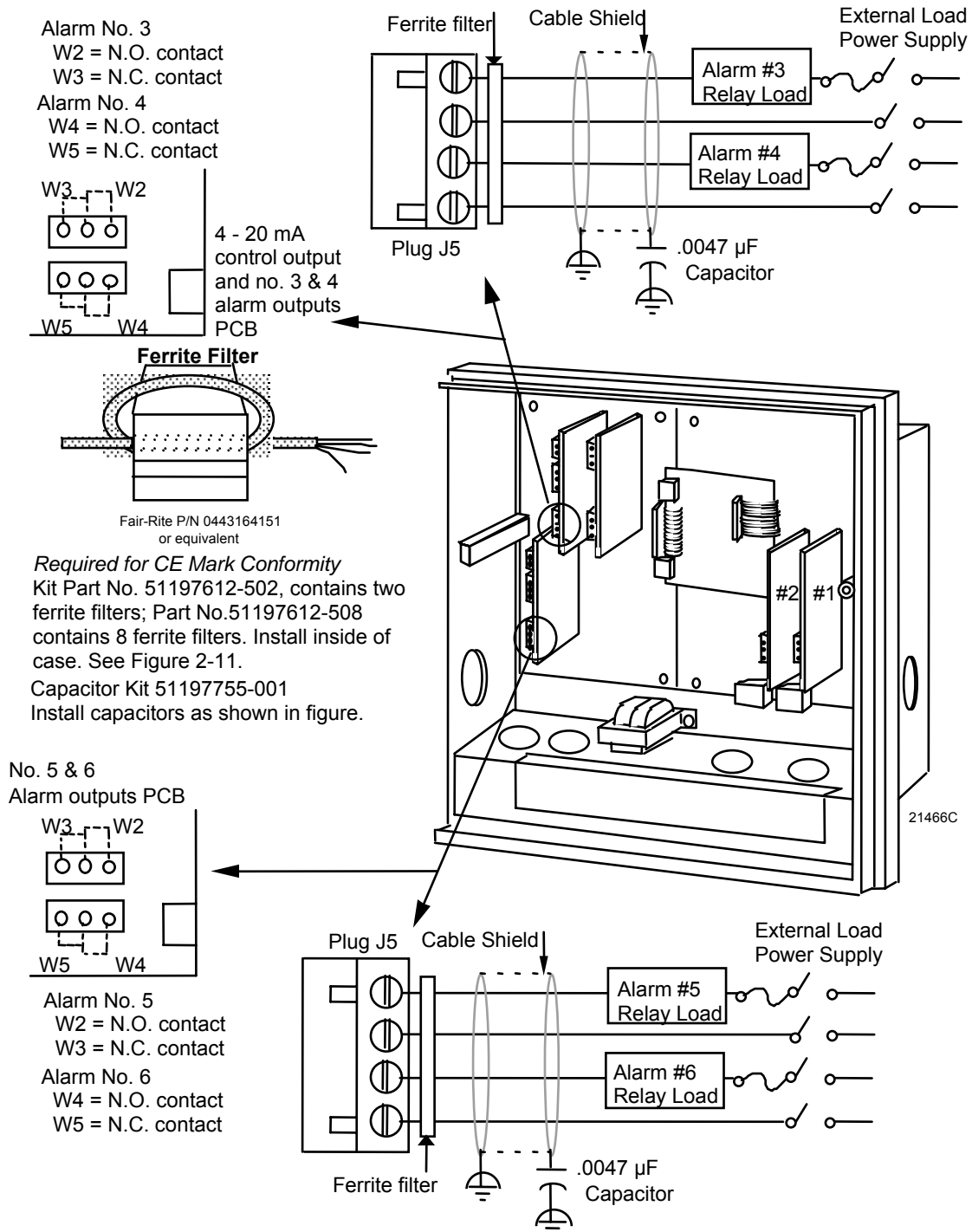


Figure 2-20 Alarm outputs #3, 4, 5, and 6 wiring

RS485 Modbus communications wiring

RS485 Modbus Communications is an option available on the DR4500A recorder.

The prerequisites are:

- Model Number - Table 3 = 3XX or 4XX

Refer to Figure 2-21 and follow the procedure in Table 2-21 to wire the RS485 Modbus communications option.

Table 2-21 RS485 Modbus communications wiring

Step	Action
1	Open the recorder door. Loosen the captive screw in the chart plate and swing the plate out.
2	Locate connector J3 on the RS485 Modbus communications option printed circuit board (refer to Figure 2-21 for location).
3	Remove the unwired plug from J3.
4	Run the communications option wires through the desired knockout.
5	For CE Mark conformity <ul style="list-style-type: none"> • Install the ferrite filter as shown in Figure 2-11. • Refer to Figure 2-21 for shield information.
6	Strip insulation from the end of each wire.
7	Loosen the screws in plug J3 terminals and position the plug as you would to plug it into J3.
8	Insert the wires for the communications option into the appropriate screw clamps as shown (refer to Figure 2-22). Tighten the screws to secure the wires.
9	Install the wired plug J3 into J3 connector on the communications board.



REFERENCE

Refer to Documents 51-52-25-66 and 51-52-25-69 for a complete description of RS485 Modbus Communications Option.

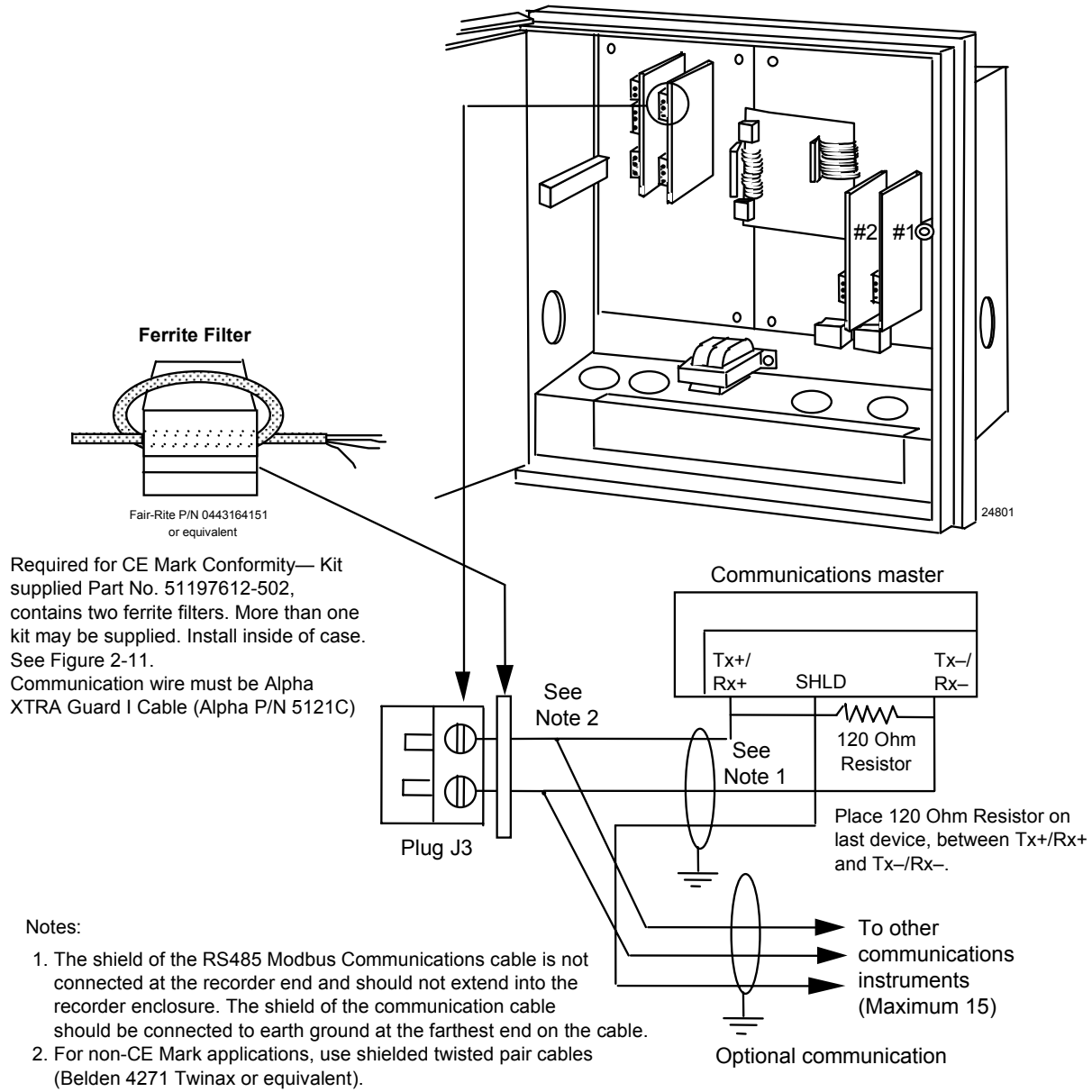


Figure 2-21 RS485 Modbus communications wiring

4-20 mA auxiliary output wiring

You can wire an auxiliary output for 4–20 mA.

The prerequisites are:

- Model Number - Table 3 = 1XX or 4XX

Refer to Figure 2-22 and follow the procedure in Table 2-22 to wire 4–20 mA auxiliary output.

Table 2-22 4-20 mA auxiliary output wiring

Step	Action
1	Open the recorder door. Loosen the captive screw in the chart plate and swing the plate out.
2	Locate connector J2 near the bottom of the auxiliary output printed circuit board (refer to Figure 2-22 for location).
3	Remove the unwired plug from J2.
4	Run the output wires through the desired knockout.
5	For CE Mark conformity, install the ferrite filter as shown in Figure 2-11.
6	Strip insulation from the end of each wire.
7	Loosen the screws in plug J2 terminals and position the plug as you would to plug it into J2.
8	Observing the polarity, insert the wires into the appropriate screw clamps as shown (refer to Figure 2-22). Tighten the screws to secure the wires.
9	Install the wired plug into J2.



ATTENTION

Be sure that the 4-20 mA auxiliary output is aligned. Refer to *subsection 8.4 Auxiliary Output Calibration*.



TIP

The 4-20 mA output on the control output board can also be set up for an Auxiliary retransmission output if it is not being used for a control output. This requires model selection option Table II = 10, 60, 66.



TIP

Auxiliary output 2 and Auxiliary output 3 use Control current output 1 and Control current output 2 if Control “OUT ALG” is not set to “CURRENT”.

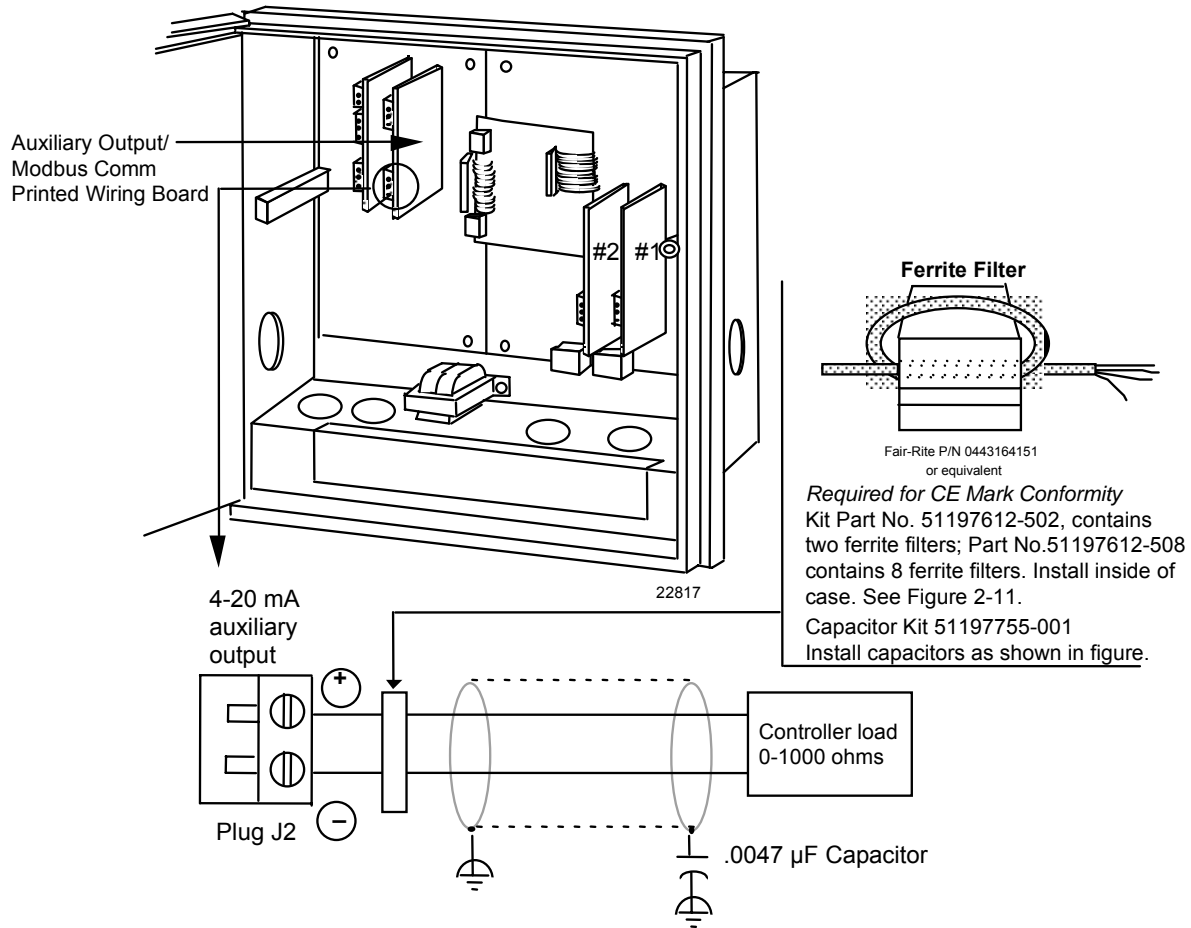


Figure 2-22 4-20 mA auxiliary output wiring



ATTENTION

Refer to Figure 2-16 for Auxiliary Output 2 and Auxiliary Output 3 wiring.

2.9 Lockout Switch Configuration

Introduction

The configuration can be locked using S1 switch located next to the microprocessor U17 on the main printed circuit board.

Restrictions based on lockout switch position

Figure 2-23 shows the location of the S1 lockout switch on the main printed circuit board.

When the lockout switch is OFF (**Down**—Configure):

- You can view and change all applicable operating parameters as described in *Section 4 – Configuration Parameter Definitions*.

When the lockout switch is ON (**Up**—Locked):

- Most parameters for the recorder are locked and the parameters may not be changed except for Tuning 1 and Tuning 2 parameters.

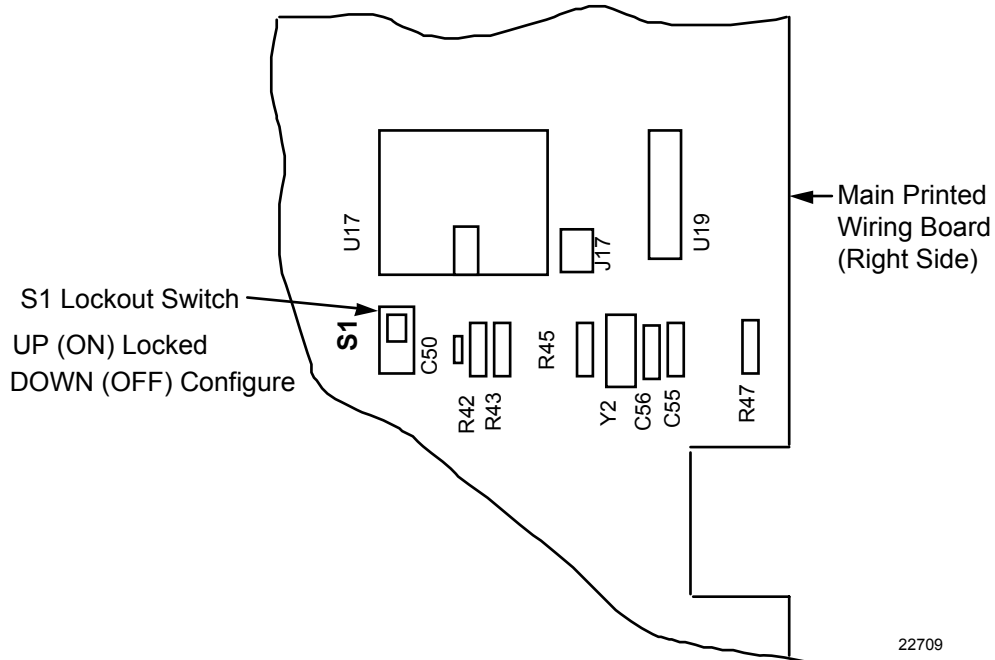


Figure 2-23 S1 lockout switch location



ATTENTION

Lockout can also be configured under set up group "LOCKOUT". See *Subsection 3.18*.

This feature also includes the special screw and plate that provide the lead seal capability for sealing the chart plate.

3. Configuration

3.1 Overview

Introduction

Configuration is a dedicated operation where you use straightforward keystroke sequences to select and establish (configure) pertinent control data best suited for your application.

What's in this section?

The table below lists the topics that are covered in this section.

	Topic	See Page
3.1	Overview	55
3.2	Configuration Prompts	56
3.3	How To Get Started	58
3.4	Configuration Tips	59
3.5	Configuration Procedure	60
3.6	Input Set Up Group	62
3.7	Pen Set Up Group	64
3.8	Chart Set Up Group	65
3.9	Totalizer Set Up Group	66
3.10	Control Set Up Group	67
3.11	Tuning Parameters Set Up Group	69
3.12	SP Ramp Set Up Groups	70
3.13	Timer Set Up Group	71
3.14	Alarms Set Up Group	72
3.15	Auxiliary Output Set Up Group	74
3.16	Modbus Communications Set Up Group	75
3.17	Options Set Up Group	76
3.18	Lockout Set Up Group	77
3.19	Configuration Record Sheet	78

Prompts

To assist you in the configuration process, there are prompts that appear in the upper and lower displays. These prompts let you know what group of configuration data (set up prompts) you are working with and also the specific parameters (function prompts) associated with each group.

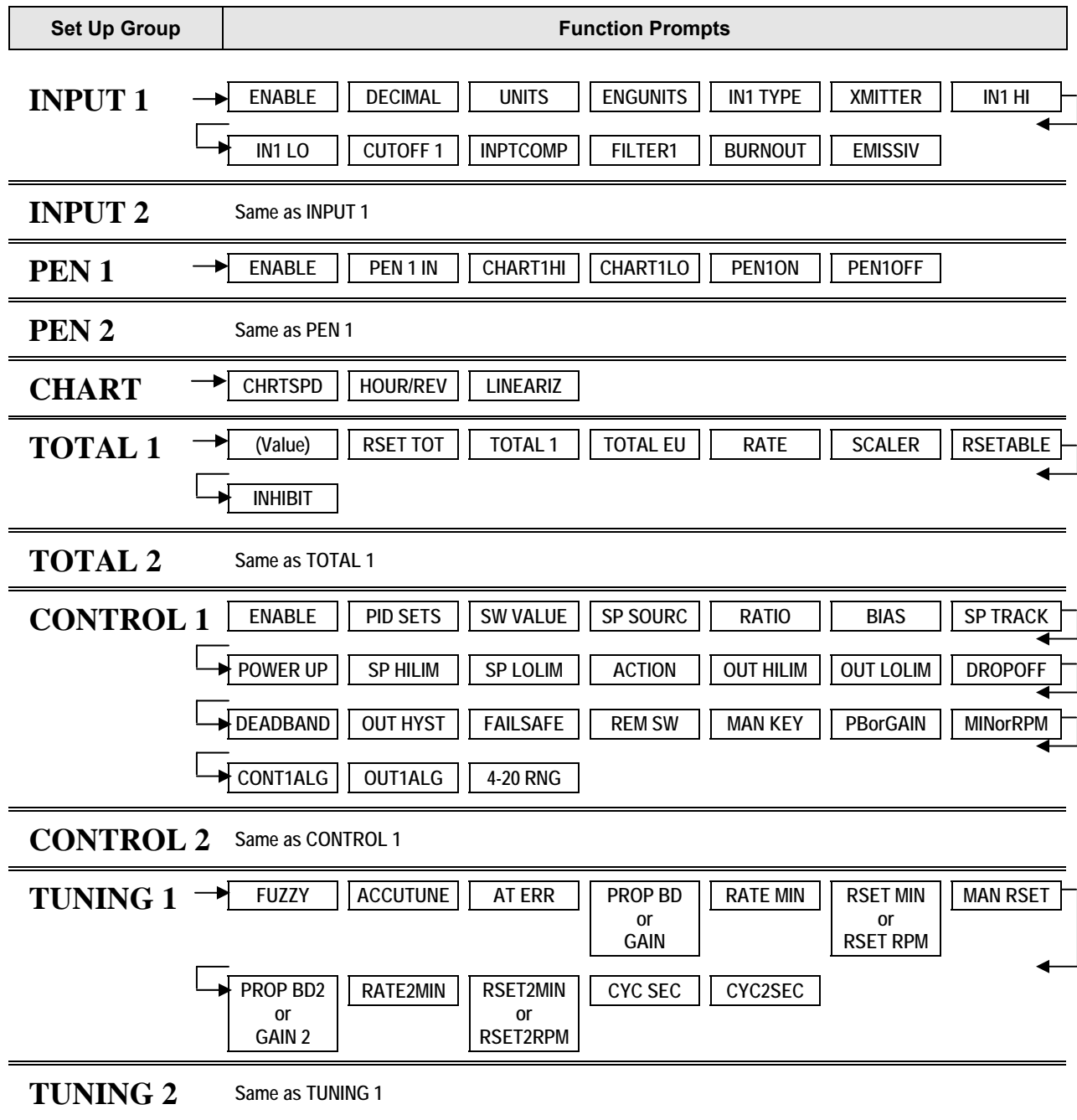
Figure 3-1 shows an overview of the prompt hierarchy.

3.2 Configuration Prompts

Diagram: prompt hierarchy

Figure 3-1 shows an overview of the DR4500A Set Up prompts and their associated Function prompt - read from left to right.

Figure 3-1 DR4500A prompt hierarchy



Set Up Group	Function Prompts																								
SP RAMP1	<table border="1"> <tr> <td>ENABLE</td> <td>SP RAMP</td> <td>TIME MIN</td> <td>FINAL SP</td> </tr> <tr> <td></td> <td>SP RATE</td> <td>EU/HR UP</td> <td>EU/HR DN</td> </tr> <tr> <td></td> <td>SP PROG</td> <td>RECYCLES</td> <td>SOAK DEV</td> </tr> <tr> <td></td> <td></td> <td>PROFILE</td> <td>STATE</td> </tr> <tr> <td></td> <td></td> <td>RECOVERY</td> <td></td> </tr> <tr> <td></td> <td>PROG END</td> <td></td> <td></td> </tr> </table>	ENABLE	SP RAMP	TIME MIN	FINAL SP		SP RATE	EU/HR UP	EU/HR DN		SP PROG	RECYCLES	SOAK DEV			PROFILE	STATE			RECOVERY			PROG END		
ENABLE	SP RAMP	TIME MIN	FINAL SP																						
	SP RATE	EU/HR UP	EU/HR DN																						
	SP PROG	RECYCLES	SOAK DEV																						
		PROFILE	STATE																						
		RECOVERY																							
	PROG END																								
SP RAMP2	Same as SP RAMP1																								
PROFILES	<table border="1"> <tr> <td>PRx STRT</td> <td>PRx END</td> <td>RAMPUNIT</td> <td>SYNC 1+2</td> </tr> </table>	PRx STRT	PRx END	RAMPUNIT	SYNC 1+2																				
PRx STRT	PRx END	RAMPUNIT	SYNC 1+2																						
SPP SEGS	<table border="1"> <tr> <td>SEGxRAMP</td> <td>SEGx SP</td> <td>SEGxTIME</td> </tr> </table>	SEGxRAMP	SEGx SP	SEGxTIME																					
SEGxRAMP	SEGx SP	SEGxTIME																							
SPP EVNT	<table border="1"> <tr> <td>SEGx EV</td> </tr> </table>	SEGx EV																							
SEGx EV																									
TIMER	<table border="1"> <tr> <td>TIMER</td> <td>PERIOD</td> <td>START</td> <td>LDISPLAY</td> <td>RESET</td> <td>ON-TIME</td> <td>INCRMENT</td> </tr> </table>	TIMER	PERIOD	START	LDISPLAY	RESET	ON-TIME	INCRMENT																	
TIMER	PERIOD	START	LDISPLAY	RESET	ON-TIME	INCRMENT																			
ALARM 1	<table border="1"> <tr> <td>A1S1 VAL</td> <td>A1S2 VAL</td> <td>A1S1TYPE</td> <td>A1S2TYPE</td> <td>A1S1 H L</td> <td>A1S1SCAL</td> <td>A1S2 H L</td> </tr> <tr> <td></td> <td>A1S2SCAL</td> <td>AL1 HYST</td> <td></td> <td></td> <td></td> <td></td> </tr> </table>	A1S1 VAL	A1S2 VAL	A1S1TYPE	A1S2TYPE	A1S1 H L	A1S1SCAL	A1S2 H L		A1S2SCAL	AL1 HYST														
A1S1 VAL	A1S2 VAL	A1S1TYPE	A1S2TYPE	A1S1 H L	A1S1SCAL	A1S2 H L																			
	A1S2SCAL	AL1 HYST																							
ALARM 2																									
ALARM 3																									
ALARM 4	Same as ALARM 1																								
ALARM 5																									
ALARM 6																									
AUX OUT	<table border="1"> <tr> <td>AUX OUT</td> <td>4 mA VAL</td> <td>20mA VAL</td> <td>AUX OUT 2</td> <td>4 mA VAL</td> <td>20mA VAL</td> <td>AUX OUT 3</td> </tr> <tr> <td></td> <td>4mA VAL</td> <td>20 mA VAL</td> <td></td> <td></td> <td></td> <td></td> </tr> </table>	AUX OUT	4 mA VAL	20mA VAL	AUX OUT 2	4 mA VAL	20mA VAL	AUX OUT 3		4mA VAL	20 mA VAL														
AUX OUT	4 mA VAL	20mA VAL	AUX OUT 2	4 mA VAL	20mA VAL	AUX OUT 3																			
	4mA VAL	20 mA VAL																							
COMM	<table border="1"> <tr> <td>ComSTATE</td> <td>Com ADDR</td> <td>BAUD</td> <td>XMT DLAY</td> <td>DBL DYTE</td> </tr> </table>	ComSTATE	Com ADDR	BAUD	XMT DLAY	DBL DYTE																			
ComSTATE	Com ADDR	BAUD	XMT DLAY	DBL DYTE																					
OPTIONS	<table border="1"> <tr> <td>REJ FREQ</td> <td>HF REJ</td> <td>RELHUMID</td> <td>ATMPRES</td> <td>DEVIATION</td> <td>DEVSETPT</td> <td>SCROLL</td> </tr> <tr> <td></td> <td>GRANDTOT</td> <td></td> <td></td> <td></td> <td></td> <td></td> </tr> </table>	REJ FREQ	HF REJ	RELHUMID	ATMPRES	DEVIATION	DEVSETPT	SCROLL		GRANDTOT															
REJ FREQ	HF REJ	RELHUMID	ATMPRES	DEVIATION	DEVSETPT	SCROLL																			
	GRANDTOT																								
LOCKOUT	<table border="1"> <tr> <td>LOCKOUT</td> </tr> </table>	LOCKOUT																							
LOCKOUT																									
ADJUST	For printing adjustments—see Troubleshooting/Service section of manual																								
CALIB	For field calibration—see Calibration section of manual																								
STATUS	<table border="1"> <tr> <td>VERSION</td> <td>FAILSAFE*</td> <td>RAM TEST</td> <td>CONFTEST</td> <td>CAL TEST</td> <td>FACT CRC</td> <td>BATTERY</td> </tr> </table>	VERSION	FAILSAFE*	RAM TEST	CONFTEST	CAL TEST	FACT CRC	BATTERY																	
VERSION	FAILSAFE*	RAM TEST	CONFTEST	CAL TEST	FACT CRC	BATTERY																			

**Displayed on test failure only*

3.3 How To Get Started

Read the configuration tips

Read *subsection 3.4 Configuration Tips* which will help you to easily and quickly configure your recorder.

Read configuration procedure

Read *subsection 3.5 Configuration Procedure* which tells you how to access the Set Up groups, and the function parameters within each of these groups that are shown in the Prompt Hierarchy in Figure 3-1.

Set Up groups

The Set Up groups and function parameters are listed in the order of their appearance. The list includes the name of the prompt, the range of setting or selections available, and the factory setting. It allows you to quickly find a parameter and obtain the available range or selection you require.

Parameter explanations or definitions

If you need a detailed explanation of any prompt listed, refer to *Section 4 – Configuration Parameter Definitions*. This section lists the set up and function prompts, the selections or range of settings that you can make for each, plus a detailed explanation or definition of each parameter.

Configuration record sheet

Located in *subsection 3.19* is a *Configuration Record Sheet*. When you make your configuration selections, record them on this sheet. Then you will have a record of how the recorder was configured.

Set up the recorder in this order:

- Inputs (Display will be correct)
- Pens
- Chart
- Alarms
- Control
- Tuning
- Other functions as needed

3.4 Configuration Tips

Introduction

Listed below in Table 3-1 are some tips that will help you enter the configuration data more quickly.

Table 3-1 Configuration tips

Function	Tip
Displaying groups	Use the SET UP key to display the Set Up groups. The group titles are listed in this section in the order that they appear in the recorder.
Displaying functions	Use the FUNC key to display the individual parameters under each group. The prompts are listed in the order of their appearance in each group.
Scrolling	<p>To get to a Set Up group prompt more quickly, hold the SET UP key in. To get to a function prompt more quickly, hold the FUNC key in. The display will scroll through the parameters.</p> <p>ATTENTION The prompting scrolls at a rate of 2/3 seconds when the SET UP or FUNC key is held in. Also, [▲] [▼] keys will move group prompts forward or backward at a rate twice as fast.</p>
Changing values quickly	<p>When Changing the value of a parameter, you can adjust a more significant digit in the upper display by holding in one key [▲] or [▼], and pressing the other [▲] or [▼] at the same time.</p> <ul style="list-style-type: none"> • The adjustment will move one digit to the left. • Press the key again and you will move one more digit to the left.
Restoring to the original value	When you change the value or selection of a parameter while in Set Up mode and decide not to enter it, press RUN/HOLD once, the original value or selection will be recalled.
Exiting Set Up mode	To exit Set Up mode, press the LOWR DISP key. This returns the display to the same state it was in immediately preceding entry into the Set Up mode.
Timing out from Set Up mode	If you are in Set Up mode and do not press any keys for one minute, the recorder will time out and revert to the mode and display that was being used prior to entry into Set Up mode.
Key error	<p>When a key is pressed and the prompt "KEY ERROR" appears in the lower display, it will be for one of the following reasons:</p> <ul style="list-style-type: none"> • parameter not available • not in Set Up mode, press SET UP key first • key malfunction, do keyboard test (operation) • individual key locked out

3.5 Configuration Procedure

Introduction

- Each of the Set Up groups and their functions are preconfigured at the factory.
- The factory settings are shown in the Set Up group tables that follow this procedure.
- If you want to change any of these selections or values, follow the procedure in Table 3-2. This procedure tells you the keys to press to get to any Set Up group and any associated Function parameter prompt.
- **If you need a detailed explanation of any prompt, refer to Section 4 – Configuration Parameter Definitions.**

Procedure

Follow the procedure listed in Table 3-2 to access the Set Up groups and Function prompts.



TIP

The prompting scrolls at a rate of 2/3 seconds when the **SET UP** or **FUNC** key is held in. Also, [▲] [▼] keys will move group prompts forward or backward at a rate twice as fast.

Table 3-2 Configuration procedure

Step	Operation	Press	Result
1	Select Set Up mode	SET UP	<i>Upper Display:</i> SET UP—Lets you know you are in the configuration mode and a Set Up group title is being displayed in the lower display. <i>Lower Display:</i> INPUT 1—This is the first Set Up group title.
2	Select any Set Up group	SET UP	<ul style="list-style-type: none"> • Successive presses of the SET UP key will sequentially display the other Set Up group titles shown in the prompt hierarchy in Figure 3-1. • You can also use the [▲] [▼] keys to scan the Set Up groups in both directions. • Stop at the Set Up group title which describes the group of parameters you want to configure. Then proceed to the next step.
3	Select a Function parameter	FUNC	<i>Upper Display:</i> Shows the current value or selection for the first function prompt of the particular Set Up group that you have selected (EXAMPLE: ENABLE/DISABLE). <i>Lower Display:</i> —Depends on what is selected in Set Up group. Shows the first function prompt within that Set Up group (EXAMPLE: INPUT 1).
4	Select other Function parameters	FUNC	<ul style="list-style-type: none"> • Successive presses of the FUNC key will sequentially display the other function prompts of the Set Up group you have selected. • Stop at the function prompt that you want to change, then proceed to the next step.

Step	Operation	Press	Result
5	Change the value or selection	▲ or ▼	<ul style="list-style-type: none"> • These keys increment or decrement the value or selection that appears for the function prompt you have selected. • See <i>subsection 3.4 Configuration Tips</i> for instructions to increase or decrease value quickly. • Change the value or selection to meet your needs. • If the display flashes, you are trying to make an unacceptable entry.
6	Enter the value or selection	FUNC or SET UP	<ul style="list-style-type: none"> • This key selects another function prompt. • This key selects another Set Up group. <p>The value or selection you have made will be entered into memory after another key is pressed.</p>
7	Exit configuration	LOWR DISP	This exits configuration mode and returns the recorder to the same state it was in immediately preceding entry into the Set Up mode. It stores any changes you have made.

3.6 Input Set Up Group

Introduction

This data deals with various parameters required to configure input 1 or input 2.

Function prompts

Table 3-3 lists all the function prompts in the "INPUT 1" Set Up group. Repeat the process for input 2.

- Press the **SET UP** key until INPUT 2 appears in the display.

Table 3-3 Input group function prompts

Function Prompt Lower Display	Function Name	Selections or Range of Setting Upper Display	Factory Setting
INPUT 1	Input 1 Actuation	DISABL ENABLE	ENABLE
DECIMAL	Decimal Point Location	XXXX None XXX.X One XX.XX Two X.XXX Three	XXX.X
UNITS	Temperature Units	DEG F DEG C XXXXX (make selection at prompt "ENGUNITS")	DEG F
ENGUNITS	Engineering Units	0 to 9 A to Z + - \ (blank)	
IN1 TYPE	Input 1 Actuation Type	B TC T TC L E TC H W TC H E TC L W TC L J TC H 100 PT J TC L 500 PT K TC H 100 RH K TC L 4-20 mA NNM TC 0-10 mV NIC TC 10-50m R TC 0-5 V S TC 0-10 V T TC H RADIAM	100 PT or 0-5 V with Control

Function Prompt Lower Display	Function Name	Selections or Range of Setting Upper Display	Factory Setting
XMITTER	Transmitter Characterization	B TC S TC E TC H T TC H E TC L T TC L J TC H W TC H J TC L W TC L K TC H 100 PT K TC L 500 PT NNM TC H 100 RH NIC TC LINEAR* R TC SQROOT* *Set "IN1 HI" and "IN1 LO"	Linear
IN1 HI	Input 1 High Range Value (linear inputs only)	-999.0 to 9999. in engineering units	900
IN1 LO	Input 1 Low Range Value (linear inputs only)	-999.0 to 9999. in engineering units	-300
CUTOFF 1	Low Flow Cutoff Selection	0 to 100% of input range	0
INPTCOMP	Input Compensation	-999.9 to 9999.	0
FILTER 1	Input 1 Filter	0 to 120 seconds	0
BURNOUT	Burnout Protection	NONE UP DOWN	UP
EMISSIV	Emissivity	.01 to 1.00	.01

Repeat this procedure for INPUT 2.

3.7 Pen Set Up Group

Introduction

The functions listed in this group deal with how to configure pen #1 or pen #2. The procedure for configuring each pen is the same. The prompts shown in Table 3-4 show PEN 1.

- Repeat the process for pen 2.
- Press the **SET UP** key until PEN 2 appears in the display.

Function prompts

Table 3-4 lists all the function prompts in the PEN Set Up groups.

Table 3-4 Pen 1 or 2 group function prompts

Function Prompt Lower Display	Function Name	Selections or Range of Setting Upper Display	Factory Setting
PEN 1	Pen Record	ENABLE DISABL	ENABLE
PEN1IN	Pen Input	INPUT1 OUTPT1 SETPT2 INPUT2 OUTPT2 DGTL1 RH SETPT1 DGTL2	INPUT 1
CHART1HI	Chart High Range Value	-999.0 to 9999	302.0
CHART1LO	Chart Low Range Value	-999.0 to 9999	292.0
PEN1ON	Pen Chart Position for ON Event	0 to 100%	91.0
PEN1OFF	Pen Chart Position for OFF Event	0 to 100%	93.0

Repeat this procedure for PEN 2.

3.8 Chart Set Up Group

Introduction

The functions listed in this group deal with the parameters that must be set to assure proper chart function.



CAUTION

Before making any configuration changes to the Chart Set Up group, place the recorder in "Chart Hold". Press the **CHART** key to stop the chart rotation. Press again after configuration entry is made.

Function prompts

Table 3-5 lists all the function prompts in the "Chart" Set Up group.

Table 3-5 Chart group function prompts

Function Prompt Lower Display	Function Name	Selections or Range of Setting Upper Display	Factory Setting
CHRTSPD	Chart Speed Selection	8HR 12HR 24HR 7DAYS XHR (See prompt "HOUR/REV")	XHR
HOUR/REV	Hours per Revolution (appears only if "XHR" is selected above)	1 to 744	12
LINEARIZ	Linearization	LINEAR NONLIN	—

3.9 Totalizer Set Up Group

Introduction

The functions listed in this group deal with the calculation and display of the total flow volume as measured by input 1 (total 1) or input 2 (total 2). The displayed value is 8 digits with a configurable scale factor.

Function prompts

Table 3-6 lists all the function prompts in the “TOTAL 1” Set Up group. Repeat the process for input 2.

- Press the **SET UP** key until TOTAL 2 appears in the display.

Table 3-6 Totalizer group function prompts

Function Prompt Lower Display	Function Name	Selections or Range of Setting Upper Display	Factory Setting
Actual Current Totalized Value	View Current Totalized Value	Current Scale Factor Example: E1 GPM	E0 GAL
RSET TOT	Reset Totalizer to Zero (RSETABLE must be set to “LOCAL”)	NO YES	NO
TOTAL 1	Totalizer 1	DISABL INPUT1 INPUT2	DISABL
TOTAL EU	Total Engineering Units	0 to 9 A to Z + - / (blank)	GAL
RATE	Rate of Integration	SECOND MINUTE HOUR DAY M/DAY (Millions of Units per Day)	SECOND
SCALER	Totalizer Scale Factor	1 10000 10 100000 100 1E6 (1,000,000) 1000	1
RSETABLE	Totalizer Reset	NO LOCAL EXTSW1* EXTSW2* *Total will be set to “0” on closure of the assigned external switch.	NO
INHIBIT	Totalizer Inhibit	NONE S1 OPEN S1 CLOSE S2 OPEN S2 CLOSE	NONE

Repeat this procedure for INPUT 2.

3.10 Control Set Up Group

Introduction

This data deals with various parameters required to effectively control your process.

Function prompts

Table 3-7 lists all the function prompts in the “CONTROL 1” or “CONTROL 2” Set Up group. You can enable the Control groups in the Option group.

Table 3-7 Control 1 or Control 2 group function prompts

Function Prompt Lower Display	Function Name	Selections or Range of Setting Upper Display	Factory Setting
CONTROL1	Control Loop 1	DISABL ENABLE	ENABLE
PID SETS	Tuning Parameter Sets	1 ONLY 2KEYBD 2PV SW 2SP SW	1 ONLY
SW VALUE	Automatic Switchover Value	–999.0 to 9999	0.00
SP SOURC	Setpoint Source	1 LOCAL REMOTE 2 LOCAL OUT 2 (available for Control 1 only) NOTE: If you select “REMOTE”, then RSP will be on Input 2.	1 LOCAL
RATIO	Ratio for Remote Setpoint	–20.00 to 20.00	1.0
BIAS	Bias for Remote Setpoint	–999.0 to 9999 in engineering units	0
SP TRACK	Setpoint Tracking	NONE RSP	NONE
POWER UP	Power Up Controller Mode Recall	MANUAL A LSP A RSP AM SP AM LSP	MANUAL
SP HILIM	High Setpoint Limit	–999.0 to 9999.	500
SP LOLIM	Low Setpoint Limit	–999.0 to 9999.	0
ACTION	Control Output Direction	DIRECT REVRSE	REVRSE
OUTHILIM	High Output Limit	–5.0 to 105.0% of output	100.0
OUTLOLIM	Low Output Limit	–5.0 to 105.0% of output	0
DROPOFF	Controller Dropoff Value	–5.0 to 105.0% of output	0.0

Function Prompt Lower Display	Function Name	Selections or Range of Setting Upper Display	Factory Setting
DEADBAND	Output Relay Deadband	<ul style="list-style-type: none"> • Time Proportional Duplex: -5.0 to 25.0% • On-Off Duplex: 0.0 to 25.0% • Position Proportional 0.5 to 5.0% 	2.0
OUT HYST	Output Relay Hysteresis	0.0 to 5.0% of PV Span	0.5
FAILSAFE	Failsafe Output Value	0 to 100%	50
REM SW	Remote Switching (Digital Input)	NONE TO 2SP TUNE TO MAN TO DIR TIMER TO LSP RN/HLD	NONE
MAN KEY	Manual Mode Key Selection	ENABLE DISABL	ENABLE
PB orGAIN	Proportional Band or Gain Units	PB PCT GAIN	GAIN
MIN orRPM	Reset Units	RPM (repeats per minute) MIN (minutes per repeat)	MIN
CONT1 ALG	Control Algorithm	ON-OFF PID-A PID-B PD+MR	PID-A
OUT1 ALG	Output Algorithm	TIME TIME D CURRNT CUR TI POSITN TI CUR	CURRENT
4-20RNG	Current/Time Duplex Range (CUR D)	100PCT (FULL) 50 PCT (SPLIT)	50PCT

Repeat this procedure for CONTROL 2.

3.11 Tuning Parameters Set Up Group

Introduction

These Tuning Set Up groups contain the Function parameters that will allow your recorder to respond correctly to changes in process variable or setpoint. You can start with predetermined values but you will have to watch your process to determine how to modify them.

Function prompts

Table 3-8 lists all the function prompts in the Tuning 1 or Tuning 2 Set Up groups. How the “Control” Set Up group is configured determines which prompts will appear.

Table 3-8 Tuning 1 or Tuning 2 group function prompts

Function Prompt Lower Display	Function Name	Selections or Range of Setting Upper Display	Factory Setting
FUZZY	Fuzzy Overshoot Suppression	DISABL ENABLE	DISABL
ACCUTUNE	Accutune II for Control Loop	DISABL ENABLE	DISABL
AT ERR	Accutune Error Codes	No message under normal conditions Read Only message displayed if tuning has been manually aborted	—
PROP BD or GAIN	Proportional Band or Gain	0.1 to 1000% 0.1 to 1000	1.0
RATE MIN	Rate in minutes	0.00 to 10.00 minutes	0.00
RSET MIN or RSET RPM	Reset in minutes/repeat or Reset in repeats/minute	0.02 to 50.00 0.02 to 50.00	1.0 1.0
MAN RSET	Manual Reset	–100 to 100% output	0.0
PROP BD2 or GAIN 2	Proportional Band 2 or Gain 2	0.1 to 1000% 0.1 to 1000	5.0
RATE2MIN	Rate 2 in minutes	0.08 to 10.00 minutes	0.00
RSET2MIN RSET2RPM	Reset 2 in minutes/repeat Reset 2 in repeats/minute	0.02 to 50.00 0.02 to 50.00	0.2 0.2
CYC SEC	Cycle Time (Heat) Electromechanical Relays	1 to 120 seconds	20.0
CYC2 SEC	Cycle Time 2 (Cool) Electromechanical Relays	1 to 120 seconds	20.0

3.12 SP Ramp Set Up Groups

The Setpoint Ramp 1 or 2 Set Up groups let you configure two setpoint ramps. Each group (SP RAMP1 and SP RAMP 2) can be configured one of three ways: ramp, rate, or setpoint program.

Setpoint Ramp

Setpoint will ramp between the current local setpoint and a final setpoint over a time interval (SP RAMP).

Setpoint Rate

The Setpoint Ramp Set Up group also contains the function parameters that let you configure a specific ramp rate up and ramp rate down (SP RATE). These rates are used when the local setpoint is manually changed.

Setpoint Program

Also included under this group are prompts for configuring a Setpoint program (SP PROG). The prompts and instructions for Setpoint programming are presented in the *Section 6 - Setpoint Ramp/Soak Programming Option*.

Function prompts

Table 3-9 lists all the function prompts in the SP RAMP 1 or SP RAMP 2 Set Up group. Configure each ramp separately. When you enable the ramp type (SP RAMP, SP RATE, SP PROG) the other two types are hidden from the display.

Table 3-9 SP Ramp 1 or 2 group function prompts

Function Prompt Lower Display	Function Name	Selections or Range of Setting Upper Display	Factory Setting
SP RAMP*	Single Setpoint Ramp Selection	DISABL ENABLE	DISABL
TIME MIN	Single Setpoint Ramp Time	0 to 255 minutes	0
FINAL SP	Single Setpoint Ramp Final Setpoint	Enter a value within the setpoint limits	100.0
SP RATE*	Setpoint Rate	DISABL ENABLE	DISABL
EU/HR UP	Rate up value (SP Rate enabled)	0 to 9999 in units per hour	0
EU/HR DN	Rate down value (SP Rate enabled)	0 to 9999 in units per hour	0
SP PROG*	Setpoint Programming (Refer to Section 6)	DISABL ENABLE	DISABL

*Only one of these can be enabled at a time.

3.13 Timer Set Up Group

Introduction

The Timer gives a countdown or elapsed time, after which Relay 1 energizes. If Timer is enabled, it has exclusive control over Relay 1; Alarm 1 will not control the relay.

Function prompts

Table 3-10 lists all the function prompts in the TIMER Set Up group.

Table 3-10 Timer group function prompts

Function Prompt Lower Display	Function Name	Selections or Range of Setting Upper Display	Factory Setting
TIMER	Timer Enable/Disable	ENABLE DISABL	DISABL
PERIOD	Timeout Period	0:00 to 99:59	0
START	Start Initiation	RHKEY ALARM2	RHKEY
LDISPLAY	Timer Display	TREM ET	TREM
RESET	Timer Reset Control	RHKEY ALARM1 REPEAT	RHKEY
ON-TIME	Timer Repeat Mode On-Time	1 SEC 2 SEC 3 SEC 4 SEC 5 SEC	
INCRMENT	Timer Count Increment	MINUTE SECOND	MINUTE

3.14 Alarms Set Up Group

Introduction

This data deals with the Alarms function that is available with your recorder.

- There are six alarms available. Each alarm has two setpoints.
- You can configure each of these two setpoints to alarm on various recorder parameters. There are two alarm output selections, high or low.
- You can also configure the two setpoints to alarm on the same event and to alarm both high and low, if desired. An adjustable hysteresis of 0.0% to 100.0% is configurable for each alarm.

Priority of functions that operate relays

During alarm conditions an alarm will deenergize its associated relay unless a higher priority function has been configured for that relay. See Table 3-11. If you want the alarm to control the relay, do not configure a higher priority function.

Table 3-11 Priority of functions that operate relays

Relay	Relay is controlled by (in order of priority)
1	1. Timer function 2. Alarm 1
2	Alarm 2 only
3	1. Controller 1 output algorithms Relay Simplex, Position Proportional, Relay Duplex, Current/Relay Duplex 2. Alarm 3
4	1. Controller 1 output algorithms Position Proportional, Relay Duplex, Current/Relay Duplex 2. Alarm 4
5	1. Controller 2 output algorithms Relay Simplex, Position Proportional, Relay Duplex, Current/Relay Duplex 2. Alarm 5
6	1. Controller 2 output algorithms Position Proportional, Relay Duplex, Current/Relay Duplex 2. Alarm 6

Function prompts

Table 3-12 lists all the function prompts in the Alarms Set Up group.

Table 3-12 Alarms group function prompts

Function Prompt Lower Display	Function Name	Selections or Range of Setting Upper Display	Factory Setting
AxS1 VAL	Alarm 1, Setpoint 1 Value	Value in engineering units	90
AxS2 VAL	Alarm 1, Setpoint 2 Value	Value in engineering units	95
AxS1TYPE	Alarm 1, Setpoint 1 Type	NONE IN 1 (Input 1) IN 2 (Input 2) RH (Relative Humidity) PV (Process Variable Loop 1) DEV (Loop 1 Deviation) OUT (Loop 1 Output) DEV2 (Loop 2 Deviation) OUT2 (Loop 2 Output) EVENT (SP Programming-Segment Event) TOTAL 1 (Totalizer to Alarm On) TOTAL 2 (Totalizer to Alarm On)	IN 1
AxS2TYPE	Alarm 1, Setpoint 2 Type	Same as A1S1TYPE	IN 1
AxS1 H L	Alarm 1, Setpoint 1 State	LO (Low Alarm) HI (High Alarm)	LO
AxS1SCAL	Alarm 1, Setpoint 1 Scaling Multiplier for Totalizer Selection	1 10000 10 100000 100 1E6 1000	1
AxS2 H L	Alarm 1, Setpoint 2 State	LO HI	HI
AxS2SCAL	Alarm 1, Setpoint 2 Scaling Multiplier for Totalizer Selection	1 10 100 1000 10000 100000 1E6	1
ALx HYST	Alarm Hysteresis	0.0 to 100.0 % of Input Span as appropriate	0.1

Repeat this procedure for ALARM 2, ALARM 3, ALARM 4, ALARM 5, ALARM 6.

3.15 Auxiliary Output Set Up Group

Introduction

The auxiliary output will supply a 4-20mA output scaled to one of four operating parameters: Input, Output, Setpoint, or Deviation. This current is supplied from a separate option card. AUX OUT 2 and AUX OUT 3 use CONTROL CURRENT OUT 1 and CONTROL CURRENT OUT 2 if CONTROL OUT ALG is not set to CURRENT.

Function prompts

Table 3-13 lists all the function prompts in the Auxiliary Output Set Up group.

Table 3-13 Auxiliary output group function prompts

Function Prompt Lower Display	Function Name	Selections or Range of Setting Upper Display	Factory Setting
AUX OUT 1	Auxiliary Output Representation	DISABL SP 1 IN 1 PV 2 IN 2 DEV 2 PV 1 OUT 2 DEV 1 SP 2 OUT 1	DISABL
4 mA VAL	Low Scaling Factor	Low scale value to represent 4 mA	0.0
20mA VAL	High Scaling Factor	High scale value to represent 20 mA	100.0

Repeat this procedure for AUX OUT 2 and AUX OUT 3.

3.16 Modbus Communications Set Up Group

Introduction

This data deals with the Communications option that is available with your recorder. This option allows the recorder to be connected to a host computer via the Modbus protocol.

If your recorder does not have this option the prompts will not appear.



ATTENTION

Refer to Documents 51-52-25-66 and 51-52-25-69 for a complete description of the RS485 Modbus Communications Option.

Function prompts

Table 3-14 lists all the function prompts in the Modbus Communications Set Up group.

Table 3-14 Modbus communications group function prompts

Function Prompt Lower Display	Function Name	Selections or Range of Setting Upper Display	Factory Setting
ComSTATE	Modbus Communications	DISABL MODBUS	DISABL
Com ADDR	Communications Station Address	1 to 99	1
BAUD	Communications Baud Rate	300 600 1200 2400 4800 9600 19200 38400	9600
XMT DLAY	Transmit Delay (in milliseconds)	NONE 10MSEC 20MSEC 30MSEC 40MSEC 50MSEC	NONE
DBL BYTE	Double Byte Order	FP B FP BB FP L FP LB	FP B

3.17 Options Set Up Group

Introduction

This data deals with various options that are available with your recorder. If your recorder does not have any of these options the prompts will not appear.

Function prompts

Table 3-15 lists all the function prompts in the Option Set Up group.

Table 3-15 Options group function prompts

Function Prompt Lower Display	Function Name	Selections or Range of Setting Upper Display	Factory Setting
REJ FREQ	Rejection Frequency	50HZ 60HZ	60HZ
HF REJ	High Frequency Rejection	ENABLE DISABL	ENABLE
RELHUMID	Relative Humidity	NO YES	NO
ATMPRES	Atmospheric Pressure Compensation	590 to 800 mmHg	—
DEVIATION	Deviation Recording Action	NONE SETPNT CHAN1	NONE
DEVSETPT	Deviation Setpoint Value	–999.0 to 9999	0
SCROLL	Lower Display Scroll	NONE 1 SEC 2 SEC 3 SEC	NONE
GRANDTOT	Grand Totalizer	ENABLE DISABL	DISABL

3.18 Lockout Set Up Group

Introduction

These are the parameters that you will select to lockout any unauthorized changes to the recorder's configuration and calibration prompts.

Function prompt

Table 3-16 lists all the function prompts in the Lockout Set Up group.

Table 3-16 Lockout group function prompts

Function Prompt Lower Display	Function Name	Selections or Range of Setting Upper Display	Factory Setting
LOCKOUT	Lockout	NONE CALIB +CONF MAX	CALIB



ATTENTION

Configuration can also be locked using S1 switch on the main printed circuit board. Refer to *Subsection 2.9 – Configuration Lockout Switch*. The chart plate can be sealed using a lead seal to provide a positive indication that the electronics and configuration lockout switch may have been accessed.

This feature also includes the special screw and plate that provide for the lead seal capability for sealing the chart plate.

3.19 Configuration Record Sheet

Keep a record

Enter the value or selection for each prompt on this sheet so you will have a record of how your recorder was configured.

Group Prompt	Function prompt	Value or Selection	Factory Setting	Group Prompt	Function prompt	Value or Selection	Factory Setting	
INPUT 1	DECIMAL	_____	XXX.X	TOTAL 2	(Value)	_____	E0 GAL	
	UNITS	_____	DEGF		RSET TOT	_____	NO	
	ENGUNITS	_____	—		TOTAL 2	_____	DISABL	
	IN1 TYPE	_____	100PT		TOTAL EU	_____	GAL	
	XMITTER	_____	LINEAR		RATE	_____	SECOND	
	IN1 HI	_____	900		SCALER	_____	1	
	IN1 LO	_____	-300		RSETABLE	_____	NO	
	CUTOFF 1	_____	0		INHIBIT	_____	NONE	
	INPTCOMP	_____	0		CONTROL 1	CONTROL1	_____	ENABLE
	FILTER 1	_____	0			PID SETS	_____	1ONLY
	BURNOUT	_____	UP			SW VALUE	_____	0.0
	EMISSIV	_____	.01			SP SOURC	_____	1LOCAL
	INPUT 2	DECIMAL	_____			XXX.X	RATIO	_____
UNITS		_____	DEGF	BIAS		_____	0	
ENGUNITS		_____	—	SP TRACK		_____	NONE	
IN2 TYPE		_____	100PT	POWER UP		_____	MANUAL	
XMITTER		_____	LINEAR	SPHILIM		_____	LAST	
IN2 HI		_____	900	SPLOLIM		_____	0	
IN2 LO		_____	-300	ACTION		_____	REVRSE	
CUTOFF 2		_____	0	OUTHILIM		_____	100.0	
INPTCOMP		_____	0	OUTLOLIM		_____	0	
FILTER 2		_____	0	DROPOFF	_____	0.0		
BURNOUT		_____	UP	DEADBAND	_____	2.0		
EMISSIV		_____	.01	OUT HYST	_____	0.5		
PEN 1		PEN1IN	_____	INPUT1	FAILSAFE	_____	50	
	CHART1HI	_____	302.0	REM SW	_____	NONE		
	CHART1LO	_____	292.0	MAN KEY	_____	ENABLE		
	PEN1ON	_____	91.0	PBorGAIN	_____	GAIN		
	PEN1OFF	_____	93.0	MINorRPM	_____	MIN		
PEN 2	PEN2IN	_____	INPUT2	CONT1ALG	_____	PIDA		
	CHART2HI	_____	302.0	OUT1ALG	_____	CURRENT		
	CHART2LO	_____	292.0	4-20 RNG	_____	50PCT		
	PEN2ON	_____	91.0					
	PEN2OFF	_____	93.0					
CHART	CHRTSPD	_____	XHR					
	HOUR/REV	_____	12					
	LINEARIZ	_____	—					
TOTAL 1	(Value)	_____	E0 GAL					
	RSET TOT	_____	NO					
	TOTAL 1	_____	DISABL					
	TOTAL EU	_____	GAL					
	RATE	_____	SECOND					
	SCALER	_____	1					
	RSETABLE	_____	NO					
	INHIBIT	_____	NONE					

Group Prompt	Function prompt	Value or Selection	Factory Setting	Group Prompt	Function prompt	Value or Selection	Factory Setting
CONTROL 2	CONTROL2	_____	ENABLE	TUNING 2	FUZZY	_____	DISABL
	PID SETS	_____	1ONLY		ACCUTUNE	_____	DISABL
	SW VALUE	_____	0.0		AT ERR	Read only	—
	SP SOURC	_____	1LOCAL		PROP BD	_____	1.0
	RATIO	_____	1.0		or		
	BIAS	_____	0		GAIN	_____	1.0
	SP TRACK	_____	NONE		RATE MIN	_____	0.00
	POWER UP	_____	MANUAL		RSET MIN	_____	1.0
	SP HILIM	_____	500		or		
	SP LOLIM	_____	0		RSET RPM	_____	1.0
	ACTION	_____	REVRSE		MAN RSET	_____	0.0
	OUTHILIM	_____	100.0		CYCSEC	_____	20.0
	OUTLOLIM	_____	0		PROP BD2	_____	1.0
	DROPOFF	_____	0.0		or		
	DEADBAND	_____	2.0		GAIN 2	_____	1.0
	OUT HYST	_____	0.5		RATE2MIN	_____	0.00
	FAILSAFE	_____	50		RSET2MIN	_____	1.0
	REM SW2	_____	NONE		or		
	MAN KEY	_____	ENABLE		RSET2RPM	_____	1.0
	PBorGAIN	_____	GAIN		CYC2SEC	_____	20.0
	MINorRPM	_____	MIN				
CONT2ALG	_____	PIDA	SP RAMP1	SP RAMP	_____	DISABL	
OUT2ALG	_____	CURRENT	TIME MIN	_____	0		
4-20 RNG	_____	50PCT	FINAL SP	_____	100.0		
TUNING 1	FUZZY	_____	DISABL	SP RATE	_____	DISABL	
	ACCUTUNE	_____	DISABL	EU/HR UP	_____	—	
	AT ERR	Read only		EU/HR DN	_____	—	
	PROP BD	_____	1.0	SP PROG	_____	DISABL	
	or			RECYCLES	_____	—	
	GAIN	_____	1.0	SOAK DEV	_____	—	
	RATE MIN	_____	0.00	PROFILE	_____	—	
	RSET MIN	_____	1.0	STATE	_____	—	
	or			RECOVERY	_____	—	
	RSET RPM	_____	1.0	PROG END	_____	—	
	MAN RSET	_____	0.0	SP RAMP2	SP RAMP	_____	DISABL
	CYCSEC	_____	20.0	TIME MIN	_____	0	
	PROP BD2	_____	1.0	FINAL SP	_____	100.0	
	or			SP RATE	_____	—	
	GAIN 2	_____	1.0	EU/HR UP	_____	—	
	RATE2MIN	_____	0.00	EU/HR DN	_____	—	
	RSET2MIN	_____	1.0	SP PROG	_____	DISABL	
	or			RECYCLES	_____	—	
	RSET2RPM	_____	1.0	SOAK DEV	_____	—	
	CYC2SEC	_____	20.0	PROFILE	_____	—	
				STATE	_____	—	
			RECOVERY	_____	—		
			PROG END	_____	—		
			PROFILES	PRx STRT	_____	—	
				PRx END	_____	—	
				RAMPUNIT	_____	—	
				SYNC 1+2	_____	—	
			SPP SEGS	SEGxRAMP	_____	—	
				SEGx SP	_____	—	
				SEGxTIME	_____	—	
			SPP EVNT	SEGx EV	_____	—	

Group Prompt	Function prompt	Value or Selection	Factory Setting	Group Prompt	Function prompt	Value or Selection	Factory Setting	
TIMER	TIMER	_____	DISABL	ALARM 5	A5S1 VAL	_____	90	
	PERIOD	_____	0:01		A5S2 VAL	_____	95	
	START	_____	KEY		A5S1TYPE	_____	INPUT1	
	LDISPLAY	_____	TREM		A5S2TYPE	_____	INPUT1	
	RESET	_____	KEY		A5S1 H L	_____	LO	
	ON-TIME	_____	—		A5S1SCAL	_____	1	
	INCRMENT	_____	MIN		A5S2 H L	_____	HI	
ALARM 1	A1S1 VAL	_____	90		A5S2SCAL	_____	1	
	A1S2 VAL	_____	95		AL5 HYST	_____	0.1	
	A1S1TYPE	_____	INPUT1		ALARM 6	A6S1 VAL	_____	90
	A1S2TYPE	_____	INPUT1			A6S2 VAL	_____	95
	A1S1 H L	_____	LO			A6S1TYPE	_____	INPUT1
	A1S1SCAL	_____	1			A6S2TYPE	_____	INPUT1
	A1S2 H L	_____	HI			A6S1 H L	_____	LO
	A1S2SCAL	_____	1	A6S1SCAL		_____	1	
AL1 HYST	_____	0.1	A6S2 H L	_____		HI		
ALARM 2	A2S1 VAL	_____	90	A6S2SCAL		_____	1	
	A2S2 VAL	_____	95	AL6 HYST	_____	0.1		
	A2S1TYPE	_____	INPUT1	AUX OUT	AUX OUT	_____	DISABL	
	A2S2TYPE	_____	INPUT1		4 mA VAL	_____	0.0	
	A2S1 H L	_____	LO		20mA VAL	_____	100.0	
	A2S1SCAL	_____	1	AUX OUT2	AUX OUT2	_____	DISABL	
	A2S2 H L	_____	HI		4 mA VAL2	_____	0.0	
A2S2SCAL	_____	1	20mA VAL2		_____	100.0		
AL2 HYST	_____	0.1	AUX OUT3	AUX OUT3	_____	DISABL		
ALARM 3	A3S1 VAL	_____		90	4 mA VAL3	_____	0.0	
	A3S2 VAL	_____		95	20mA VAL3	_____	100.0	
	A3S1TYPE	_____	INPUT1	COMM	ComSTATE	_____	DISABL	
	A3S2TYPE	_____	INPUT1		Com ADDR	_____	1	
	A3S1 H L	_____	LO		BAUD	_____	9600	
	A3S1SCAL	_____	1		XMT DLAY	_____	NONE	
	A3S2 H L	_____	HI	DBL BYTE	_____	FP B		
A3S2SCAL	_____	1	OPTIONS	REJ FREQ	_____	60		
AL3 HYST	_____	0.1		HF REJ	_____	ENABLE		
ALARM 4	A4S1 VAL	_____		90	RELHUMID	_____	NO	
	A4S2 VAL	_____		95	ATMPRES	_____	—	
	A4S1TYPE	_____		INPUT1	DEVIATION	_____	NONE	
	A4S2TYPE	_____		INPUT1	DEVSETPT	_____	0	
	A4S1 H L	_____		LO	SCROLL	_____	NONE	
	A4S1SCAL	_____		1	GRANDTOT	_____	DISABL	
	A4S2 H L	_____	HI	LOCKOUT	LOCKOUT	_____	CALIB	
	A4S2SCAL	_____	1				XXXX	
AL4 HYST	_____	0.1						

4. Configuration Parameter Definitions

4.1 Overview

Introduction

This section provides information for all the user-configurable control parameters listed in the configuration section. If you aren't familiar with these parameters, this section gives you the parameter prompt, the selection or range of setting that you can make, and a definition of how each parameter setting affects recorder performance. It will also refer you to any other prompts that might be affected by your selection.

Parameter groups and prompts

- The control information is found in three configuration groups which are accessed by the **SET UP** key.
- Each of these groups contains prompts, viewed in the lower display, which deal with functions that are pertinent to that particular group. These are accessed by pressing the **FUNC** key.
- The selections or values are listed in the upper display. Refer to *Section 3 - Configuration* for step by step instructions.

What's in this section?

The table below lists the topics that are covered in this section. They are listed in the order of their appearance in the recorder.

	Topic	See Page
4.1	Overview	83
4.2	Input Parameters Set Up Group	84
4.3	Pen Parameters Set Up Group	88
4.4	Chart Parameters Set Up Group	90
4.5	Total Parameters Set Up Group	91
4.6	Control Parameters Set Up Group	93
4.7	Tuning Parameters Set Up Group	102
4.8	Setpoint Ramp Set Up Group	105
4.9	Timer Set Up Group	107
4.10	Alarms Set Up Group	108
4.11	Auxiliary Output Set Up Group	111
4.12	Modbus Communications Set Up Group	113
4.13	Options Set Up Group	114
4.14	Lockout Parameters Set Up Group	116

4.2 Input Parameters Set Up Group

Introduction

These are the parameters required for input 1 or 2, temperature units, decimal location, actuation, transmitter characterization, high and low range values in engineering units, input compensation, filter, and burnout.

Input group prompts

Table 4-1 lists all the function prompts in the Input 1 or 2 setup group and their definitions.

Table 4-1 Input group definitions

Lower Display Prompt	Upper Display Range of Setting or Selection	Parameter Definition
DECIMAL	XXXX XXX.X XX.XX X.XXX	DECIMAL POINT LOCATION -- This selection determines where the decimal point appears in the display. None One Place Two Places Three Places NOTE: Auto-ranging will occur when one decimal position has been selected and the value increases above 999.9 but auto-ranging <i>will not</i> similarly occur when two decimal positions are selected.
UNITS	DEG F DEG C EU	TEMPERATURE UNITS -- This selection will be indicated on the PV display. If you select EU, go to prompt "ENGUNITS" Degrees Fahrenheit Degrees Celsius Engineering Units
ENGUNITS	0 to 9 A to Z + - / (blank)	ENGINEERING UNITS – Make up 5 selections to create unit identifier. <ul style="list-style-type: none"> For example, create unit identifier H₂O by selecting an "H" from A to Z, a "2" from 0 to 9, and an "O" from A to Z. For alphanumeric entries, the display will cycle, from left to right, with highlighting (increased brightness) of each digit. The value of each digit can be changed only when it is highlighted.

Lower Display Prompt	Upper Display Range of Setting or Selection	Parameter Definition
INn TYPE (n = 1 or 2)	B TC E TC H E TC L J TC H J TC L K TC H K TC L NNM TC NIC TC R TC S TC T TC H T TC L W TC H W TC L 100 PT 500 PT 100 RH 4-20mA 0-10mV 10-50m 0-5 V 0-10 V RADIAM LINEAR SQROOT	INPUT ACTUATION TYPE -- This selection determines what actuation you are going to use for input one. Be sure that the values configured for high and low chart range, soak setpoint, alarm setpoint, etc. are within the measuring range for the selected actuation type. B thermocouple 105 to 3300°F 41 to 1815°C E thermocouple high -454 to 1832°F -270 to 1000°C E thermocouple low -200 to 1100°F -129 to 593°C J thermocouple high 0 to 1600°F -18 to 871°C J thermocouple low 20 to 770°F -7 to 410°C K thermocouple high -320 to 2500°F -196 to 1371°C K thermocouple low -20 to 1000°F -29 to 538°C NNM NiNiMo thermocouple 32 to 2500°F 0 to 1371°C NIC Nicrosil-Nisil thermocouple 0 to 2372°F -178 to 1300°C R thermocouple 0 to 3100°F -18 to 1704°C S thermocouple 0 to 3100°F -18 to 1704°C T thermocouple high -300 to 700°F -184 to 371°C T thermocouple low -200 to 500°F -129 to 316°C W5W26 thermocouple high 0 to 4200°F -18 to 2316°C W5W26 thermocouple low 0 to 2240°F -18 to 1227°C 100 Ohm-RTD -300 to 1200°F -184 to 649°C 500 Ohm-RTD -300 to 900°F -184 to 482°C 100 Ohm-RTD -130 to 392°F -90 to 200°C 4 to 20 Milliamps ² 0 to 10 Millivolts ² 10 to 50 Millivolts ² 0 to 5 Volts ² 0 to 10 Volts ² Radiamatic 1400 to 3400°F 760 to 1871°C Linear -999.9 to 9999 Square Root -999.9 to 9999 ¹ These selections appear only with XMITTER prompt, which appears only if a linear type is configured input type. ² Go to prompt "XMITTER" to characterize the input.

Lower Display Prompt	Upper Display Range of Setting or Selection	Parameter Definition
<p>XMITTER</p>	<p>B TC E TC H E TC L J TC H J TC L K TC H K TC L NNM H NIC TC R TC S TC T TC H T TC L W TC H W TC L 100 PT 500 PT 100 RH LINEAR SQROOT</p>	<p>TRANSMITTER CHARACTERIZATION — This selection lets you instruct the recorder to characterize a linear input to represent a nonlinear one.</p> <ul style="list-style-type: none"> NOTE: Prompt only appears when a linear actuation is selected at prompt 'IN1 TYPE'. FOR EXAMPLE: If input 1 is a 4 to 20 mA signal, but the signal represents a type "K" thermocouple; select "K TC H" and the recorder will characterize the 4 to 20 mA signal so that it is treated as a type "K" thermocouple input (high range). <p>B Type Thermocouple E Type Thermocouple High E Type Thermocouple Low J Type Thermocouple High J Type Thermocouple Low K Type Thermocouple High K Type Thermocouple Low NNM NiNiMo Type Thermocouple High NIC Nicrosil Nilil Thermocouple R Type Thermocouple S Type Thermocouple T Type Thermocouple High T Type Thermocouple Low W5W26 Type Thermocouple High W5W26 Type Thermocouple Low 100 Ohm-RTD 500 Ohm-RTD 100 Ohm -RTD Linear Range Extracts Square Root</p>
<p>INn HI (n = 1 or 2)</p>	<p>–999.9 to 9999. or –999 to 9999 in engineering units</p>	<p>INPUT HIGH RANGE VALUE in engineering units is displayed for all inputs but can only be configured for linear or square root transmitter characterization. Otherwise, this is a read-only display of the higher range value for the selected T/C or RTD input including transmitter characterization, if applicable.</p> <ul style="list-style-type: none"> Scale the #1 input signal to the display value you want for 100%. EXAMPLE: Actuation (Input) = 4 to 20 mA Process Variable = Flow Range of Flow = 0 to 250 Gal/Min High Range display value = 250 Then 20 mA = 250 Gal/Min <p>The control setpoint will be limited by the range of units selected here.</p>

Lower Display Prompt	Upper Display Range of Setting or Selection	Parameter Definition
INn LO (n = 1 or 2)	–999.9 to 9999. or –999 to 9999 in Engineering units	INPUT LOW RANGE VALUE in engineering units is displayed for all inputs but can only be configured for linear or square root transmitter characterization. <ul style="list-style-type: none"> Otherwise, this is a read-only display of the low range value for the selected T/C or RTD input including transmitter characterization, if applicable. Scale the input signal to the display value you want for 0%. See example on previous page. The control setpoint for Input will be limited by the range of units selected here.
CUTOFF n (n = 1 or 2)	0 to 100% of Input Range	LOW FLOW CUTOFF —Lets you set a value in percent of range below which the applicable totalizer does not increment. ATTENTION Prompt appears only if totalizer option is present in the recorder.
INPTCOMP	–999.9 to 9999.	INPUT COMPENSATION — used to compensate the input for drift of an input value due to deterioration of a sensor, or some other cause; select the value you want on the input.
FILTER n (n = 1 or 2)	0 to 120 seconds No filter = 0	FILTER FOR INPUT — a software digital filter is provided for the input to smooth the input signal. You can configure the first order lag time constant from 1 to 120 seconds. If you do not want filtering, enter 0.
BURNOUT	NONE UP DOWN	BURNOUT PROTECTION (SENSOR BREAK) provides most input types with upscale or downscale protection if the input fails. <ul style="list-style-type: none"> Not available for inputs 0-5V, 0-10V, or 4-20 mA. NO BURNOUT — Failsafe output applied for failed input. UPSCALE BURNOUT will make the indicated PV signal increase when a sensor fails, and flash the upper display. DOWNSCALE BURNOUT will make the indicated PV signal decrease when a sensor fails, and flash the upper display. NOTE: For no Burnout (that is, “None”) to function properly on a linear input, there must be a dropping resistor directly across the <i>input</i> terminals (that is, not remote), then the unit can detect the “zero” voltage that occurs when the 4-20 mA line is opened.
EMISSIV	.01 to 1.00	EMISSIVITY is a correction factor applied to the Radiamatic input signal that is the ratio of the actual energy emitted from the target to the energy which would be emitted if the target were a perfect radiator. Available only for “Radiamatic” inputs.

Repeat the procedure for INPUT 2 configuration.

4.3 Pen Parameters Set Up Group

Introduction

The functions listed in this group deal with how to configure pen #1 or pen #2. The procedure for configuring each pen is the same. The prompts shown in Table 4-2 show PEN 1.

- Press the **SET UP** key until PEN 1 or PEN 2 appears in the display.

Pen 1 or 2 group prompts

Table 4-2 lists all the function prompts in the Pen 1 or Pen 2 set up groups and their definitions.

Table 4-2 Pen 1 or 2 group definitions

Lower Display Prompt	Upper Display Range of Setting or Selection	Parameter Definition
PENn (n = 1 or 2)	ENABLE DISABL	PEN RECORD —This selection lets you enable or disable the pen (channel) record <ul style="list-style-type: none"> • Remember, the lower display prompt could read PEN2.
PENnIN (n = 1 or 2)	INPUT 1 INPUT 2 RH OUTPT1 OUTPT2 SETPT1 SETPT2 DGTL1 DGTL2	PEN INPUT —What do you want the pen to record? INPUT 1 —records Input 1 INPUT 2 —records Input 2 RELATIVE HUMIDITY —records in %RH. It initiates an external calculation for measuring relative humidity. INPUT 1, IN TYP must be configured for 100 PT. INPUT 2, IN TYP must be configured for 100 RH. The RH prompt only appears when RELHUMID prompt in the OPTIONS group is configured as YES. OUTPUT 1 —records Output 1 OUTPUT 2 —records Output 2 SETPOINT 1 —records Setpoint 1 SETPOINT 2 —records Setpoint 2 DIGITAL 1 INPUT —records EVENT pen function on contact closure across digital 1 input. DIGITAL 2 INPUT —records EVENT pen function on contact closure across digital 2 input.
CHARTnHI (n = 1 or 2)	–999.0 to 999	CHART HIGH RANGE VALUE —Enter a value that corresponds with the chart high range value for pen 1 (pen 2).
CHARTnLO (n = 1 or 2)	–999.0 to 999	CHART RANGE LOW VALUE —Enter a value that corresponds with the chart low range value for pen 1 (pen 2). <ul style="list-style-type: none"> • CHART HI minus CHART LO equals Chart Range (must be whole number = 2 or greater).

Lower Display Prompt	Upper Display Range of Setting or Selection	Parameter Definition
<p>PENnON (n = 1 or 2)</p>	<p>0 to 100%</p>	<p>PEN CHART POSITION FOR ON EVENT — This is the event marker configuration using digital inputs. Select the chart position where pen 1 (pen 2) is to mark (trace) occurrence of an ON event.</p> <ul style="list-style-type: none"> • Prompt only appears if DGTL1 or 2 is selected as pen 1 (pen 2) input.
<p>PENnOFF (n = 1 or 2)</p>	<p>0 to 100%</p>	<p>PEN CHART POSITION FOR OFF EVENT — This is the event marker configuration using digital inputs. Select the chart position where pen 1 (pen 2) is to mark (trace) occurrence of an OFF event.</p> <ul style="list-style-type: none"> • Prompt only appears if DGTL1 or 2 is selected as pen 1 (pen 2) input.

Repeat this procedure for PEN 2 configuration.

4.4 Chart Parameters Set Up Group

Introduction

The functions listed in this group deal with how the chart will be set up.



CAUTION

Before making any configuration changes to the “Chart” Set Up group, place the recorder in “Chart Hold”. Press the **CHART** key to stop the chart rotation. Press again after configuration entry is made.

Chart group prompts

Table 4-3 lists all the function prompts in the chart parameters setup group and their definitions.

Table 4-3 Chart parameters group definitions

Lower Display Prompt	Upper Display Range of Setting or Selection	Parameter Definition
CHRTSPD	8HR 12HR 24HR 7DAYS XHR	CHART SPEED — This is the time it will take to drive the chart one complete revolution. 8 Hour revolution 12 Hour revolution 24 Hour revolution 7 Day revolution X hour revolution - make Hours per Revolution selection at prompt “HOUR/REV”.
HOUR/REV	1 to 744 Hours	HOURS PER REVOLUTION — Set the desired chart speed. Appears only if XHR was selected at prompt “CHRT SPD”.
LINEARIZ	LINEAR NONLIN	LINEARIZATION

4.5 Total Parameters Set Up Group

Introduction

The functions listed in this group deal with the calculation and display of the total flow volume as measured by Input 1 (Total 1), or Input 2 (Total 2). The displayed value is eight digits with a configurable scale factor.

Totalizer 1 and 2 group prompts

Table 4-4 lists all the function prompts in the Totalizer 1 and 2 Set Up group and their definitions.

Table 4-4 Totalizer group definitions

Lower Display Prompt	Upper Display Range of Setting or Selection	Parameter Definition
(Actual Current totalized value)	(Current scale factor) Example: E1 GPM	VIEW CURRENT TOTALIZED VALUE — this selection lets you view the current totalized value. <ul style="list-style-type: none"> In the example shown, E1 represents exponential value of total (total times 10^1). GPM represents total engineering units selected. See “SCALER” and “TOTAL EU” function prompts in this group for selections.
RSETTOT	YES NO	RESET TOTALIZER TO ZERO — this selection lets you reset the totalizer to zero. <ul style="list-style-type: none"> Selecting YES will reset the totalizer to zero. Function prompt “RSETABLE” must be set to “LOCAL”.
TOTAL1 TOTAL 2	DISABL INPUT 1 INPUT 2	TOTALIZATION FOR INPUT 1 OR 2 — this selection allows you to select the input to Totalizer 1 or 2. <ul style="list-style-type: none"> Not DISABL allows selection of the rest of the prompts associated with totalization.
TOTAL EU	0 to 9 A to Z + – / (blank)	TOTAL ENGINEERING UNITS — this selection allows you to make up to 3 selections to create a unit identifier that the total represents. <ul style="list-style-type: none"> For alphanumeric entries, the display will cycle, from left to right, with highlighting (increased brightness) of each digit. The value of each digit can be changed only when it is highlighted.

Lower Display Prompt	Upper Display Range of Setting or Selection	Parameter Definition
RATE	SECOND MINUTE HOUR DAY M/DAY	<p>RATE OF INTEGRATION — This selection allows you to select the desired rate of integration. It must match scaling of input units:</p> <p>EXAMPLE:</p> <p>GPM must use "MINUTE" PPH must use "HOUR"</p> <p>SECOND - EU (Engineering Units) per second. MINUTE - EU per minute HOUR - EU per hour DAY - EU per day M/DAY - Millions of Units per day (multiplier) 10⁶ x input</p>
SCALER	1 10 100 1000 10000 100000 1E6	<p>TOTALIZER SCALE FACTOR — this selection allows you to select a scale factor (that is, a Multiplier) for the totalizer display. It affects only the display.</p> <ul style="list-style-type: none"> The desired factor is applied to the calculated value to extend the maximum flow range that can be displayed. Scaler selection does not affect the totalization value printed on the chart. <p>EXAMPLE:</p> <ul style="list-style-type: none"> 1E6 equals 1 times 10⁶ (1,000,000)
RSETABLE	NO LOCAL EXT SW1 EXT SW2	<p>LOCAL TOTALIZER RESET— Allows the totalizer value to be reset to zero via the display/keypad.</p> <p>EXTERNAL SWITCH 1—Allows the totalizer to be set to zero upon switch #1 closure. (Digital Input #1)</p> <p>EXTERNAL SWITCH 2—Allows the totalizer to be set to zero upon switch #2 closure. (Digital Input #2)</p>
INHIBIT	NONE S1 OPEN S1 CLOSE S2 OPEN S2 CLOSE	<p>The totalizer will be inhibited while the configured action is true.</p> <p>External SW1 open inhibits totalizer. External SW1 closed inhibits totalizer. External SW2 open inhibits totalizer. External SW2 closed inhibits totalizer.</p>

Repeat the configuration for TOTAL 2.

4.6 Control Parameters Set Up Group

Introduction

The functions listed in this group deal with how the DR4500A will control the process including: number of tuning parameter sets, setpoint source, ratio, bias, tracking, power-up recall, setpoint limits, output direction and limits, deadband and hysteresis, control algorithm, output algorithm, and the current duplex range. There are two control groups.

Control group prompts

Table 4-5 lists all the function prompts in the Control 1 or Control 2 set up groups and their definitions.

Table 4-5 Control 1 or 2 group definitions

Lower Display Prompt	Upper Display Range of Setting or Selection	Parameter Definition
CONTROL 1	ENABLE DISABL	CONTROL 1 — allows you to enable or disable control loop #1.
PID SETS		NUMBER OF TUNING PARAMETER SETS — this selection lets you choose one or two sets of tuning constants (gain, rate, and reset).
	1 ONLY	ONE SET ONLY — only one set of tuning parameters is available. Configure the values for: Gain (proportional band) Rate Reset Time Cycle Time (if time proportional is used)
	2KEYBD	TWO SETS KEYBOARD SELECTABLE — two sets of tuning parameters can be configured and can be selected at the operator interface. <ul style="list-style-type: none"> Press LOWR DISP key until you see "PID SET1" or "PID SET2" to switch between sets. Configure the values for: Gain, Rate , Reset, Cycle Time Gain #2, Rate #2, Reset #2, Cycle #2 Time
2PV SW	TWO SETS PV AUTOMATIC SWITCHOVER — when the process variable is <i>GREATER</i> than the value set at prompt "SW VALUE" (Switchover Value), the recorder will use Gain, Rate, Reset, and Cycle Time. The active PID SET can be read in the lower display. <ul style="list-style-type: none"> When the process variable is <i>LESS</i> than the value set at prompt "SW VALUE," the recorder will use Gain #2, Rate #2, Reset #2, and Cycle #2 Time. The active PID SET can be read in the lower display. Other prompts affected: SW VALUE 	

Lower Display Prompt	Upper Display Range of Setting or Selection	Parameter Definition
PID SETS (continued)	2SP SW	<p>TWO SETS SP AUTOMATIC SWITCHOVER — when the setpoint is <i>GREATER</i> than the value set at prompt "SW VALUE" (Switchover Value), the recorder will use Gain, Rate, Reset, and Cycle.</p> <ul style="list-style-type: none"> When the setpoint is <i>LESS</i> than the value set at prompt "SW VALUE," the recorder will use Gain #2, Rate #2, Reset #2, and Cycle #2. Other prompts affected: SW VALUE
SW VALUE	-999.0 to 9999	<p>AUTOMATIC SWITCHOVER VALUE —this is the value of process variable or setpoint at which the recorder will switch from Tuning Constant Set #2 to Set #1. Only appears when PID SETS selections "2PV SW" or "2SP SW" are selected.</p>
SP SOURC		<p>SETPOINT SOURCE — this selection determines what your setpoint source will be; One local or Two local. Toggled by the "SETPOINT SELECT" key.</p>
	1LOCAL	<p>LOCAL SETPOINT — the setpoint entered from the keyboard or from the setpoint program.</p>
	REMOTE	<p>REMOTE SETPOINT — a signal is brought in through the second input printed circuit board connector J2 and used as the control setpoint.</p> <ul style="list-style-type: none"> If you select "REMOTE", Input #2 is automatically assigned as your RSP source for CONTROL #1; there is no remote setpoint for CONTROL #2. Ratio and Bias can be applied to the remote setpoint. Mutually exclusive with 2 Local setpoints. Other prompts affected: RATIO, BIAS.
	2LOCAL	<p>TWO LOCAL SETPOINTS — this selection lets you switch between two local setpoints. Mutually exclusive with Remote setpoint.</p>
	OUT2	<p>Only for Loop 1— Setpoint is the output of Control Loop 2.</p>
RATIO	-20.00 to 20.00	<p>RATIO — used when input 2 operates as a remote setpoint, prompt "REMOTE."</p> <ul style="list-style-type: none"> This ratio value can be applied to the remote setpoint. It establishes the correct relationship between the remote setpoint and the input 2 signal applied according to the formula below (under Bias). Input 2 must be enabled.

Lower Display Prompt	Upper Display Range of Setting or Selection	Parameter Definition
BIAS	–9999 to 9999 (engineering units)	<p>BIAS — used when input 2 operates as a remote setpoint (prompt "REMOTE").</p> <ul style="list-style-type: none"> Bias, together with ratio, establishes the correct relationship between the remote setpoint and the input 2 signal applied according to the formula: $\text{REMOTE SETPOINT} = \text{IN2 VALUE (RATIO)} + \text{BIAS}$ <p>NOTE: IN2 VALUE = Actual (engineering units)</p> <ul style="list-style-type: none"> All values must be within configured setpoint high and low limits. Input 2 must be enabled.
SP TRACK		<p>SETPOINT TRACKING — the local setpoint can be configured to track the remote setpoint as listed below:</p>
	NONE	<ul style="list-style-type: none"> NO TRACKING — if local setpoint tracking is not configured, the LSP will not be altered when transfer from RSP to LSP is made.
	RSP	<ul style="list-style-type: none"> LSP (LOCAL SETPOINT) TRACKS RSP (REMOTE SETPOINT) IN AUTO — if configured, when the recorder transfers out of remote setpoint, the last value of the remote setpoint (RSP) is inserted into the local setpoint.
POWER UP		<p>POWER UP CONTROLLER MODE RECALL — this selection determines which mode and setpoint the recorder will use when the it restarts after a power loss. Select one from below:</p>
	MANUAL	<ul style="list-style-type: none"> MANUAL, LSP — at power-up, the recorder will use <i>manual</i> mode with the output value displayed.
	A LSP	<ul style="list-style-type: none"> AUTOMATIC, LOCAL SETPOINT — at power-up, the recorder will return to the <i>automatic</i> mode and will use the local setpoint for control.
	A RSP	<ul style="list-style-type: none"> AUTOMATIC, REMOTE SETPOINT — at power-up, the recorder will return to the <i>automatic</i> mode and will use the remote setpoint for control.
	AM SP	<ul style="list-style-type: none"> LAST MODE, LAST SETPOINT used before power down.
	AM LSP	<ul style="list-style-type: none"> LAST MODE, LAST LOCAL SETPOINT on power down.
SP HILIM	–999.0 to 9999. input units	<p>SETPOINT HIGH LIMIT* — this selection prevents the local and remote setpoints from going above the value selected here. The setting must be equal to or less than the upper range of input 1 and input 2. Input 2, when configured for remote setpoint, will be restricted to this upper limit.</p>

Lower Display Prompt	Upper Display Range of Setting or Selection	Parameter Definition
SP LOLIM	-999.0 to 9999. inputs units	SETPOINT LOW LIMIT* — this selection prevents the local and remote setpoints from going below the value selected here. The setting must be equal to or greater than the lower range of input 1 and input 2. Input 2, when configured for remote setpoint, will be restricted to this lower limit.
ACTION		CONTROL OUTPUT DIRECTION — in what direction do you want the recorder output to go when the process variable increases.
	DIRECT	DIRECT ACTING CONTROL — the recorder's output <i>increases</i> as the process variable increases.
	REVRSE	REVERSE ACTING CONTROL — the recorder's output <i>decreases</i> as the process variable increases.
OUTHILIM	-5.0 to 105.0% of output	HIGH OUTPUT LIMIT — this is the highest value of output beyond which you do not want the recorder automatic output to exceed. Use 0 to 100% for time proportional output type.
OUTLOLIM	-5.0 to 105.0% of output	LOW OUTPUT LIMIT — this is the lowest value of output below which you do not want the recorder automatic output to exceed. Use 0 to 100% for time proportional output type.
DROPOFF	-5 to 105.0% of output	CONTROLLER DROPOFF VALUE — select an output value that below which the recorder output will droppoff to the low output limit value set in prompt "OUT LOLIM."
DEADBAND	-5.0 to 25.0% 0 to 25.0% 0.5 to 5.0%	DEADBAND is an adjustable gap between the operating ranges of output 1 and output 2 in which neither output operates (positive value) or both outputs operate (negative value). It is the difference between the nominal trip points of relay 1 and relay 2. Time Duplex On-Off Duplex Position Proportional
OUT HYST	0.0 to 5.0% of PV span	HYSTERESIS (OUTPUT RELAY ONLY) is an adjustable overlap of the ON/OFF states of each control output. This is the difference between the value of the process variable at which the control outputs energize and the value at which they de-energize. Only applicable for ON-OFF control.
FAILSAFE	0 to 100%	FAILSAFE OUTPUT VALUE — the output level used when you have communications SHED or when NO BURNOUT is configured and input 1 fails.

*The Local Setpoint will automatically adjust itself to be within the setpoint limit range. For example, if SP = 1500 and the SP HILIM is changed to 1200, the new Local Setpoint will be 1200.

Lower Display Prompt	Upper Display Range of Setting or Selection	Parameter Definition
REM SW REM SW2		REMOTE SWITCHING (DIGITAL INPUT) — contact closure enables one of the following:
	NONE	NO DIGITAL INPUT SELECTION
	TO MAN	TO MANUAL — contact closure selects Manual mode.
	TO LSP	TO LOCAL SETPOINT — contact closure selects the local setpoint.
	TO 2SP	TO LOCAL SETPOINT 2 — contact closure selects local setpoint 2.
	TO DIR	TO DIRECT ACTION — contact closure selects Direct Control Action.
	RN/HLD	RUN/HOLD — contact closure suspends setpoint Ramp/Program. Contact open resumes.
	TUNE	AUTOTUNE — contact closure initiates Autotune.
	TIMER	TIMER — starts the timer, if enabled. The Timer can also be started by the RH KEY or ALARM2. These parameters are found under the Timer set up group.
MAN KEY		MANUAL MODE KEY SELECTION — make selection to enable or disable the Manual Mode selection through the MAN/AUTO key.
	ENABLE	ENABLE — allows you to use the MAN/AUTO key to select Manual Mode.
	DISABL	DISABLE — disables the MAN/AUTO key.
PBorGAIN		PROPORTIONAL BAND UNITS — select one of the following for the Proportional (P) term of the PID algorithm:
	PB PCT	<ul style="list-style-type: none"> PROPORTIONAL BAND — selects units of percent proportional band for the P term of the PID algorithm, where: $PB\% = \frac{100\%FS}{GAIN}$
	GAIN	<ul style="list-style-type: none"> GAIN selects the unitless term of gain for the P term of the PID algorithm, where: $GAIN = \frac{100\%FS}{PB\%}$

Lower Display Prompt	Upper Display Range of Setting or Selection	Parameter Definition
MINorRPM		RESET UNITS — selects units of minutes or repeat per minutes for the I term of the PID algorithm. 20 Repeats per Minute = 0.05 Minutes per Repeat.
	RPM	REPEATS PER MINUTE — the number of times per minute that the proportional action is repeated by reset.
	MIN	MINUTES PER REPEAT — the time between each repeat of the proportional action by reset.
CONT1ALG		The CONTROL ALGORITHM lets you select the type of control that is best for your process. ATTENTION If the recorder has two controllers (both enabled), CONT1ALG applies for controller #1 and CONT2ALG applies for controller #2.
	ON-OFF	ON/OFF is the simplest control type. The output can be either ON (100%) or OFF (0%). The Process Variable (PV) is compared with the setpoint (SP) to determine the sign of the error (ERROR = PV-SP). The ON/OFF algorithm operates on the sign of the error signal. <ul style="list-style-type: none"> In Direct Acting Control, when the error signal is positive, the output is 100%; and when the error signal is negative, the output is 0%. If the control action is reverse, the opposite is true. An adjustable overlap (Hysteresis Band) is provided between the on and off states. Other prompts affected: "OUT HYST" DUPLEX ON/OFF is an extension of this algorithm when the output is configured for Duplex. It allows the operation of a second ON/OFF output. There is a deadband between the operating ranges of the two inputs and an adjustable overlap (hysteresis) of the on and off states of each output. Both Deadband and Hysteresis are separately adjustable. With no relay action the controller will read 50%. <ul style="list-style-type: none"> Other prompts affected: "OUT HYST" and "DEADBAND"

Lower Display Prompt	Upper Display Range of Setting or Selection	Parameter Definition
CONT1ALG (continued)	PID A NOTE: PID A should not be used for Proportional only action (that is, no integral (reset) action.) Instead, use PD+MR with rate set to 0.	<p>PID A is normally used for three-mode control. This means that the output can be adjusted somewhere between 100% and 0%. It applies all three control actions — Proportional (P), Integral (I), and Derivative (D) — to the error signal.</p> <p><i>Proportional (Gain)</i> — regulates the controller's output in proportion to the error signal (the difference between Process Variable and Setpoint).</p> <p><i>Integral (Reset)</i> — regulates the controller's output to the size of the error and the time the error has existed. (The amount of corrective action depends on the value of proportional Gain.)</p> <p><i>Derivative (Rate)</i> — regulates the controller's output in proportion to the rate of change of the error. (The amount of corrective action depends on the value of proportional Gain.)</p>
	PID B	<p>PID B unlike the PID-A equation, the controller gives only an integral response to a setpoint change, with no effect on the output due to the gain or rate action, and it gives full response to PV changes. Otherwise controller action is as described for the PID-A equation. See note on PID-A.</p>
	PD+MR	<p>PD WITH MANUAL RESET is used whenever integral action is not wanted for automatic control. The equation is computed with no integral contribution. The MANUAL RESET, which is operator adjustable, is then added to the present output to form the controller output. Switching between manual and automatic mode will not be bumpless.</p> <ul style="list-style-type: none"> • If you select PD with Manual Reset you can also configure the following variations: <ul style="list-style-type: none"> – PD (Two Mode) control, – P (Single Mode) control. <p>Set Rate (D) and/or Reset Time (I) to 0.</p> <ul style="list-style-type: none"> • Other prompts affected: "MAN RSET"

Lower Display Prompt	Upper Display Range of Setting or Selection	Parameter Definition
OUT1ALG		<p>The OUTPUT ALGORITHM lets you select the type of output you want.</p> <p>ATTENTION If the recorder has two controllers (both enabled), OUT1ALG applies for controller #1 and OUT2ALG applies for controller #2. <i>Selections are model dependent. For example, current output models cannot be configured for Time Proportioning Simplex Output.</i></p>
	TIME	<p>RELAY SIMPLEX — type of output using one SPDT relay. Its normally open (NO) or normally closed (NC) contacts are selected by positioning an internal jumper.</p> <ul style="list-style-type: none"> • Other prompts affected: "OUT HYST" • Controller #1 uses Relay 3 and overrides control of relay by Alarm 3. Controller #2 uses Relay 5 and overrides control of relay by Alarm 5.
	CURRNT	<p>CURRENT SIMPLEX — type of output using one 4 to 20 mA signal that can be fed into a positive or negative grounded load of 0 to 1000 ohms. The signal can be recalibrated for any desired range from 3.25 to 21 mA for 0 to 100% output.</p>
	POSITN	<p>POSITION PROPORTIONAL SIMPLEX — type of output using two SPDT relays and a motor which has a 100 to 1000 ohms feedback slidewire.</p> <ul style="list-style-type: none"> • Other prompt affected: "DEADBAND" • Controller #1 uses Relays 3 and 4 and overrides control of relays by Alarms 3 and 4. Controller #2 uses Relays 5 and 6 and overrides control of relays by Alarms 5 and 6.
	TIME D	<p>RELAY DUPLEX — type of output using two SPDT relays. Its normally open (NO) or normally closed (NC) contacts are selected by positioning an internal jumper (see Installation section).</p> <ul style="list-style-type: none"> • Other prompts affected: "DEADBAND" • Controller #1 uses Relays 3 and 4 and overrides control of relays by Alarms 3 and 4. Controller #2 uses Relays 5 and 6 and overrides control of relays by Alarms 5 and 6.
	CUR TI	<p>CURRENT/RELAY DUPLEX (RELAY = HEAT) is a variation of duplex with current active for 0 to 50% output (tuning set 2) and relay active for 50 to 100% output (tuning set 1).</p> <ul style="list-style-type: none"> • Other prompts affected: "4-20 RNG," "DEADBAND" • Controller #1 uses Relay 3 and overrides control of relay by Alarm 3. Controller #2 uses Relay 5 and overrides control of relay by Alarm 5.

Lower Display Prompt	Upper Display Range of Setting or Selection	Parameter Definition
OUT1ALG (continued)	TI CUR	<p>RELAY/CURRENT DUPLEX (RELAY = COOL) is similar to "CUR-TI" except that current is active for 50 to 100% and relay is active for 0 to 50%.</p> <ul style="list-style-type: none"> • Other prompts affected: "4-20 RNG," "DEADBAND" • Controller #1 uses Relay 4 and overrides control of relay by Alarm 4. Controller #2 uses Relay 6 and overrides control of relay by Alarm 6.
4-20 RNG		<p>CURRENT DUPLEX RANGE ALGORITHM — used with Output Algorithm selections "CUR-TI" or "TI-CUR."</p>
	50 PCT	<p>CURRENT DUPLEX RANGE (SPLIT) enables the normal control current output to provide its full range for 50% output change.</p> <ul style="list-style-type: none"> • If "CUR-TI" duplex was selected, the current output provides cool control.
	100PCT	<p>CURRENT DUPLEX RANGE (FULL) enables the normal control current output to provide duplex heat control over 0-100% output change and the relay output to provide cool control.</p>

Repeat this procedure for CONTROL 2 configuration.

4.7 Tuning Parameters Set Up Group

Introduction

Tuning consists of establishing the appropriate values for the tuning constants you are using so that your recorder responds correctly to changes in process variable and setpoint. You can start with predetermined values but you will have to watch the system to see how to modify them. There are two Tuning groups available.

Tuning group prompts

Table 4-6 lists all the function prompts in the Tuning 1 and Tuning 2 setup group and their definitions.

Table 4-6 Tuning group prompt definitions

Lower Display Prompt	Upper Display Range of Setting or Selection	Parameter Definition
FUZZY	DISABL ENABLE	FUZZY OVERSHOOT SUPPRESSION FEATURE DISABLE —Disables fuzzy overshoot suppression ENABLE —The recorder will use fuzzy logic to suppress or minimize any overshoot that may occur as a result of the existing tuning parameters. It does NOT change the parameters.
ACCUTUNE	DISABL ENABLE	ACCUTUNE II —On demand tuning algorithm DISABLE —Disables ACCUTUNE II ENABLE —TUNExOFF will be displayed as a status message. Use the Increment or Decrement key to toggle status to TuneON. New PID parameters will be entered automatically when tuning is complete.
AT ERR	NONE IDFL ABRT RUN	ACCUTUNE ERROR CODES (Read Only)

Lower Display Prompt	Upper Display Range of Setting or Selection	Parameter Definition
<p>PROP BD or GAIN</p>	<p>0.1 to 1000% or 0.1 to 1000</p>	<p>PROPORTIONAL BAND is the percent of the range of the measured variable for which a proportional recorder will produce a 100% change in its output.</p> <p>GAIN is the ratio of output change (%) over the measured variable change (%) that caused it.</p> $G = \frac{100\%}{PB\%}$ <p>where PB is the proportional band (in %)</p> <ul style="list-style-type: none"> • If the PB is 20%, then the Gain is 5. Likewise, a 3% change in the error signal (SP-PV) will result in a 15% change in the recorder's output due to proportional action. If the gain is 2, then the PB is 50%. • Used with control algorithm PID-A or PID-B. Defined as "HEAT" Gain on Duplex models for variations of Heat/Cool applications. • The selection of Proportional Band or Gain is made in the control parameter group under prompt "PBorGAIN."
<p>RATE MIN</p>	<p>0.08 to 10.00 minutes 0.08 or less = OFF</p>	<p>RATE action affects the recorder's output whenever the deviation is changing; and affects it more when the deviation is changing faster.</p> <ul style="list-style-type: none"> • Used with control algorithm PID-A or PID-B. Defined as "HEAT" Rate on Duplex models for variations of Heat/Cool applications.
<p>RSET MIN or RSET RPM</p>	<p>0.02 to 50.00</p>	<p>RSET MIN = RESET IN MINUTES / REPEAT RSET RPM = RESET IN REPEATS / MINUTE</p> <p>RESET adjusts the recorder's output in accordance with both the size of the deviation (SP-PV) and the time it lasts. The amount of the corrective action depends on the value of Gain. The Reset adjustment is measured as how many times proportional action is repeated/minute.</p> <ul style="list-style-type: none"> • Used with control algorithm PID-A or PID-B. Defined as "HEAT" Reset on Duplex models for variations of Heat/Cool applications. • The selection of minutes per repeat or repeats per minute is made in the control parameters group under prompt "MINorRPM."
<p>MAN RSET</p>	<p>-100 to +100 (in % output)</p>	<p>MANUAL RESET is only applicable if you have control algorithm PD WITH MANUAL RESET. Because a proportional recorder will not necessarily line out at setpoint, there will be a deviation (offset) from setpoint. This eliminates the offset and lets the PV line out at setpoint.</p>

Lower Display Prompt	Upper Display Range of Setting or Selection	Parameter Definition
PROP BD2 or GAIN 2	0.1 to 1000% or 0.1 to 1000	PROPORTIONAL BAND 2 or GAIN 2 , RATE 2 , and RESET 2 parameters are the same as previously described for "Heat" except that they refer to the cool zone tuning constants on duplex models or the second set of PID constants, whichever is pertinent.
RATE2MIN	0.08 to 10.00 minutes 0.08 or less = OFF	
RSET2MIN RSET2RPM	0.02 to 50.00	
CYC SEC	1 to 120 seconds	CYCLE TIME (HEAT) determines the length of one time proportional output relay cycle. Defined as "HEAT" cycle time for Heat/Cool applications. <ul style="list-style-type: none"> • Electromechanical relays
CYC2 SEC	1 to 120 seconds	CYCLE TIME 2 (COOL) is the same as above except it applies to Duplex models as the cycle time in the "COOL" zone of Heat/Cool applications or for second set of PID constants. <ul style="list-style-type: none"> • Electromechanical relays

4.8 Setpoint Ramp Set Up Group

Introduction

The Setpoint Ramp 1 and 2 Set Up groups contain the Function parameters that enable you to configure two setpoints. Each setpoint (SP RAMP 1 and SP RAMP 2) can be configured only one of three ways: ramp, rate, or setpoint program.

Single Setpoint Ramp

Setpoint will ramp between the current local setpoint and a final setpoint over a time interval of up to 255 minutes (SP RAMP).

Setpoint Rate

The Setpoint Ramp Set Up group also contains the function parameters that let you configure a specific rate of change for any local setpoint change (SP RATE). It includes selections for Rate Up and Rate Down.

Setpoint Program

Also included under this group are prompts for configuring a 36-segment Setpoint program (SP PROG). The prompts and instructions for Setpoint programming are presented in the *Section 6 Setpoint Ramp/Soak Programming Option*.

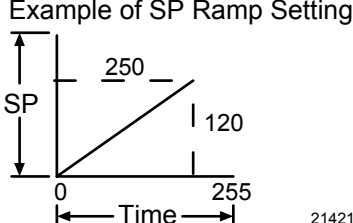
- You can start and stop the ramp/program using the **RUN/HOLD** key.

Setpoint Ramp/ Program group prompts

Table 4-7 lists all the function prompts in the Setpoint Ramp 1 or 2 setup group and their definitions. When you enable the ramp type (SP RAMP, SP RATE, SP PROG) the other two types are hidden from the display.

Table 4-7 Setpoint Ramp 1 or 2 group definitions

Lower Display Prompt	Upper Display Range of Setting or Selection	Parameter Definition
SP RAMP	ENABLE DISABL	<p>SINGLE SETPOINT RAMP — Make selection to enable or disable the setpoint ramp function. Make sure you configure a ramp time and a final setpoint value. “SP PROG” and “SP RATE” must be disabled.</p> <p>ENABLE SETPOINT RAMP — Allows you to start the setpoint ramp (in automatic mode).</p> <p>DISABLE SETPOINT RAMP — Disables the setpoint ramp.</p>

Lower Display Prompt	Upper Display Range of Setting or Selection	Parameter Definition
TIME MIN	0 to 255 minutes	<p>SETPOINT RAMP TIME — Enter the number of minutes desired to reach the final setpoint.</p> <p>A ramp time of “0” implies an immediate change of setpoint.</p> <p>Example of SP Ramp Settings:</p> 
FINAL SP	Within SP limits	<p>SETPOINT RAMP FINAL SETPOINT — Enter the value desired for the final setpoint. The recorder will operate at the setpoint set here when ramp is ended.</p>
SP RATE (option)	<p>ENABLE</p> <p>DISABL</p>	<p>SETPOINT RATE—Lets you configure a specific rate of change for any local setpoint change. “SP RAMP” and “SP PROG” must be disabled.</p> <p>ENABLE SETPOINT RATE—Allows the SP rate feature.</p> <p>DISABLE SETPOINT RATE—Disables the setpoint rate.</p>
EU/HR UP	0 to 9999 in Engineering Units per hour	<p>RATE UP—Value for SP Rate selection.</p>
EU/HR DN	0 to 9999 in Engineering Units per hour	<p>RATE DOWN—Value for SP Rate selection.</p>
SP PROG (option)	<p>ENABLE</p> <p>DISABL</p>	<p>SETPOINT RAMP/SOAK PROGRAM Available only with recorders that contain this option. “SP RAMP” and “SP RATE” must be disabled.</p> <p>For reasons of convenience, the information for the prompts when SP PROG is enabled are included in <i>Section 6 Setpoint Ramp/Soak Programming Option</i>.</p>

4.9 Timer Set Up Group



Introduction

The Timer gives a countdown or elapsed time, after which Relay 1 energizes. If Timer is enabled, it has exclusive control over Relay 1; that is, Alarm 1 will not control the relay.

Timer group prompts

Table 4-8 lists all the function prompts in the Timer setup group and their definitions.

Table 4-8 Timer group definitions

Lower Display Prompt	Upper Display Range of Setting or Selection	Parameter Definition
TIMER	ENABLE DISABL	Lets you enable or disable the timer option.
PERIOD	0:00 to 99:59	Configures the length of the timeout period (from 0 to 99 hours, 59 minutes).
START	RH KEY ALARM 2	Selects whether the Timer starts with the keyboard (Run/Hold key) or Alarm 2. The Timer can also be started by a discrete input, REM SW or REM SW2. These prompts are found under the Control Set Up Group.
LDISPLAY	TREM ET	Select whether time remaining (TREM) or elapsed time (ET) is displayed for the timer option. The time is shown on the lower display in hh:mm format along with a rotating "clock" character. Time remaining: If the "clock" rotation is clockwise, elapsed time is indicated.  □.□□ Elased time: If the "clock" rotation is counterclockwise, time left is indicated.  □.□□
RESET	RH KEY ALARM 1 REPEAT	Selects whether the Timer resets with the keyboard (Run/Hold key) or Alarm 1. In Repeat Mode, the timer restarts immediately upon timeout and activates the relay for 1 to 5 seconds.
ON-TIME	1 SEC 2 SEC 3 SEC 4 SEC 5 SEC	Relay 1 on-time when timer is in repeat mode.
INCRMENT	MINUTE SECOND	Selects the units of the timer.

4.10 Alarms Set Up Group

Introduction

An alarm is an indication that an event that you have configured (for example—Process Variable) has exceeded one or more alarm limits. There are six alarms available, each with two setpoints. You can configure each of these two setpoints to alarm on various controller parameters. There are two alarm output selections, high and low. You can configure each setpoint to alarm either high or low. These are called single alarms. You can also configure the two setpoints to alarm on the same event and to alarm both high and low. An adjustable hysteresis of 0.0% to 100.0% is configurable for each alarm setpoint.

Priority of functions that operate relays

During alarm conditions an alarm will deenergize its associated relay unless a higher priority function has been configured for that relay. See Table 4-9. If you want the alarm to control the relay, do not configure a higher priority function.

Table 4-9 Priority of functions that operate relays

Relay	Relay is controlled by (in order of priority)
1	1. Timer function 2. Alarm 1
2	Alarm 2 only
3	1. Controller 1 output algorithms Relay Simplex, Position Proportional, Relay Duplex, Current/Relay Duplex 2. Alarm 3
4	1. Controller 1 output algorithms Position Proportional, Relay Duplex, Current/Relay Duplex 2. Alarm 4
5	1. Controller 2 output algorithms Relay Simplex, Position Proportional, Relay Duplex, Current/Relay Duplex 2. Alarm 5
6	1. Controller 2 output algorithms Position Proportional, Relay Duplex, Current/Relay Duplex 2. Alarm 6

Alarms group prompts

Table 4-10 lists all the function prompts in the Alarms setup group and their definitions. These prompts repeat for all 6 alarms.



TIP

To configure an alarm for a setpoint program segment event, program either type (AxS1TYPE or AxS2TYPE) as EVENT. It is not necessary to configure any other alarm prompts.

Table 4-10 Alarms group definitions

Lower Display Prompt	Upper Display Range of Setting or Selection	Parameter Definition
AxS1 VAL	Value in engineering units	ALARM x SETPOINT 1 VALUE — this is the value at which you want the alarm type chosen in prompt "AxS1TYPE" to actuate. The value depends on what the setpoint has been configured to represent. NO setpoint is required for Communications SHED. For SP Programming the value is the segment number for which the event applies.
AxS2 VAL	Value in engineering units	ALARM x SETPOINT 2 VALUE — this is the value at which you want the alarm type chosen in prompt "AxS2TYPE" to actuate. • The details are the same as "AxS1 VAL".
AxS1TYPE	NONE IN 1 IN 2 RH DEV (loop 1) OUT (loop 1) DEV2 (loop 2) OUT2 (loop 2) EVENT TOTAL 1 TOTAL 2	ALARM x SETPOINT 1 TYPE — select what you want Setpoint 1 of Alarm 1 to represent. It can represent any of the Inputs, Relative Humidity, Deviation (loop 1 or 2), Output (loop 1 or 2), and if you have a model with communications, you can configure the recorder to alarm on SHED. If you have setpoint programming, you can alarm when a segment goes ON or OFF (loop 1 or 2). An alarm can also be set to activate if a totalizer value has exceeded a configured alarm value. NO ALARM INPUT 1 INPUT 2 RELATIVE HUMIDITY LOOP 1 DEVIATION LOOP 1 OUTPUT LOOP 2 DEVIATION LOOP 2 OUTPUT EVENT ON (SP PROGRAMMING) TOTALIZER TO ALARM ON TOTALIZER TO ALARM ON
AxS2TYPE	Same as AxS1TYPE	ALARM x SETPOINT 2 TYPE — select what you want Setpoint 2 of Alarm x to represent. The selections are the same as AxS1TYPE.

Lower Display Prompt	Upper Display Range of Setting or Selection	Parameter Definition
<p>AxS1 H L</p>	<p>H I LO</p>	<p>ALARM x SETPOINT 1 STATE — select whether you want the alarm type chosen in prompt "AxS1TYPE" to alarm high or low or the beginning or end of a segment in setpoint Ramp/Soak programming.</p> <p>HI ALARM – Relay coil is de-energized when the PV is above the setpoint. LO ALARM – Relay coil is de-energized when the PV is below the setpoint.</p>
<p>AxS1SCAL</p>	<p>1 10 100 1000 10000 100000 1E6</p>	<p>MULTIPLIER FOR ALARM TYPE "TOTAL" SELECTION — the alarm is only a high value. Enter a scaler of from 1 to 1000000.</p> <p>(Base value x multiplier = alarm setpoint value)</p>
<p>AxS2 H L</p>	<p>H I LO</p>	<p>ALARM x SETPOINT 2 STATE — select whether you want the alarm type chosen in prompt "AxS2TYPE" to alarm high or low or the beginning or end of a segment in setpoint Ramp/Soak programming.</p> <p>HI ALARM LO ALARM</p>
<p>AxS2SCAL</p>	<p>1 10 100 1000 10000 100000 1E6</p>	<p>MULTIPLIER FOR ALARM TYPE "TOTAL" SELECTION — the alarm is only a high value. Enter a scaler of from 1 to 1000000.</p> <p>(Base value x multiplier = alarm setpoint value)</p>
<p>ALx HYST</p>	<p>0.0 to 100.0% of span or full output as appropriate</p>	<p>ALARM HYSTERESIS — an adjustable hysteresis is provided on each alarm such that when the alarm is OFF it activates at exactly the alarm setpoint; when the alarm is ON, it will not deactivate until the variable is 0.0% to 100.0% (whatever has been set) away from the alarm setpoint.</p> <ul style="list-style-type: none"> • Configure the hysteresis of the alarms based on INPUT signals as a % of input range span. • Configure the hysteresis of the alarm based on OUTPUT signals as a % of the full scale output range.

Repeat this procedure for Alarm 2, Alarm 3, Alarm 4, Alarm 5, Alarm 6 configuration.

4.11 Auxiliary Output Set Up Group

Introduction

This provides a milliampere output representing any of twelve control parameters: Input 1-2, PV 1-2, Deviation 1-2, Output 1-2, Setpoint 1-2. The display for auxiliary Output viewing will be in engineering units for all but output. Output will be designated in percent (%).

Timer group prompts

Table 4-11 lists all the function prompts in the Auxiliary Output setup group and their definitions.

Table 4-11 Auxiliary output group definitions

Lower Display Prompt	Upper Display Range of Setting or Selection	Parameter Definition
AUX OUT		<p>AUXILIARY OUTPUT SELECTION provides an mA output representing any of twelve control parameters. The display for Auxiliary Output viewing will be in engineering units for all but output. Output will be designated in percent (%).</p> <ul style="list-style-type: none"> Other prompts affected by these selections: "4 mA VAL" and "20mA VAL".
	DISABL	NO AUXILIARY OUTPUT
	IN 1	<p>INPUT 1—This represents the configured range of input 1. FOR EXAMPLE: Type "J" Thermocouple (0 to 1600°F) 0°F display = 0% output 1600°F display = 100% output</p>
	IN 2	INPUT 2 —This represents the value of the configured range of input 2.
	PV 1	PROCESS VARIABLE 1 —Represents the value of the Process Variable for Loop 1. PV = Input 1 + Bias
	DEV 1	<p>DEVIATION 1 (PROCESS VARIABLE MINUS SETPOINT)—Represents –100 to +100% of the selected PV span in engineering units for Loop 1. FOR EXAMPLE: Type "T" Thermocouple PV range = –300 to +700°F PV span = 1000°F Deviation range = –1000 to +1000°F If PV = 500°F and SP = 650°F then Deviation Display = –150°F Auxiliary Output = 42.5%</p> <p>NOTE: A deviation of 0°F yields an auxiliary output of 50%.</p>
	OUT 1	OUTPUT 1 —Represents the displayed controller output in percent (%) for Loop 1.

Lower Display Prompt	Upper Display Range of Setting or Selection	Parameter Definition
AUX OUT (continued)	SP 1	SETPOINT 1 —Represents the value of the setpoint in units of PV for Loop 1.
	PV 2	PROCESS VARIABLE 2 —Represents the value of the process variable for Loop 2.
	DEV 2	DEVIATION 2 (PROCESS VARIABLE MINUS SETPOINT) —Represents –100 to +100% of the selected PV span for Loop 2. See Example at DEV 1.
	OUT 2	OUTPUT 2 —Represents the displayed controller output in percent (%) for Loop 2.
	SP 2	SETPOINT 2 —Represents the value of the setpoint in units of PV for Loop 2.
4 mA VAL	Low Scale Value within the range of the selected variable to represent 4 mA	AUXILIARY OUTPUT LOW SCALING FACTOR —Use a value in engineering units for all selections above except Output. Use value in percent (%) for Output. (Output can be between –5 and +105%.)
20mA VAL	High Scale Value within the range of the selected variable to represent 20 mA	AUXILIARY OUTPUT HIGH SCALING FACTOR —Use a value in engineering units for: Input 1, Input 2, Process Variable, Deviation,* and Setpoint. Use a value in percent (%) for Output. (Output can be between –5 and +105%.) *When Deviation is selected, only one operating parameter will be entered. This value represents the deviation level that will produce 20 mA output. Zero deviation will produce a center scale (12 mA) output. A negative deviation equal in magnitude to the Auxiliary Output High Value will produce a low end (4 mA) output.

Repeat for AUX OUT 2 and AUX OUT 3.

4.12 Modbus Communications Set Up Group

Introduction

This option allows the DR4500A to be connected to a host computer via the Modbus protocol. Up to 99 addresses and a maximum of 15 units can be configured over this link.



REFERENCE

Refer to Documents 51-52-25-66 and 51-52-25-69 for a complete description of the RS485 Modbus Communications Option.

Communications group prompts

Table 4-12 lists all the function prompts in the Modbus Communications set up group and their functions.

Table 4-12 Modbus communications group definitions

Lower Display Prompt	Upper Display Range of Setting or Selection	Parameter Definition
ComSTATE	DISABL MODBUS	DISABL —Disables the communications option. MODBUS —Allows Modbus communication prompts.
Com ADDR	1 to 99	COMMUNICATIONS STATION ADDRESS — This is a number that is assigned to the recorder that is to be used with the communications option.
BAUD	300 600 1200 2400 4800 9600 19200 38400	BAUD RATE is the transmission speed in bits per second. 300 Baud 600 Baud 1200 Baud 2400 Baud 4800 Baud 9600 Baud 19200 Baud 38400 Baud
XMT DLAY	NONE 10MSEC 20MSEC 30MSEC 40MSEC 50MSEC	TRANSMIT DELAY —This is the approximate time delay between receipt of Modbus request message and start of response message (in addition to message processing time).
DBL BYTE	FP B FP BB FP L FP LB	DOUBLE REGISTER BYTE ORDER —The transmitted or received order of the 4 bytes comprising an IEEE floating point value. The default order is EXP, MH, MM, ML, or 0123 for reference. 0123 (Big Endian) 1032 (Big Endian, Byte Swapped) 3210 (Little Endian) 2301 (Little Endian, Byte Swapped)

4.13 Options Set Up Group

Introduction

The Options Set Up Group lets you enable or disable some of the options that are available on the DR4500. You can select the power frequency, select relative humidity as a measurement and a atmospheric pressure compensation, select deviation recording action, and set the desired deviation setpoint.

Options group prompts

Table 4-13 lists all the function prompts in the Option set up group and their functions.

Table 4-13 Option group definitions

Lower Display Prompt	Upper Display Range of Setting or Selection	Parameter Definition
REJ FREQ	60HZ 50HZ	REJECTION FREQUENCY – be sure that this selection agrees with the line voltage frequency.
HF REJ	ENABLE DISABL	HIGH FREQUENCY REJECTION – This selection allows high frequency noise rejection. It is used to quiet noisy pens or PV. ATTENTION For fast processes it will cause additional lag.
RELHUMID	NO YES	RELATIVE HUMIDITY – allows you to activate or deactivate the RH calculation algorithm. <ul style="list-style-type: none"> You must select 100RH input type for two inputs to measure RH. It requires two 100-ohm RTD inputs so INPUT 2 must be enabled for this prompt to appear. Also, you must select RH for “PEN2IN” which represents the “wet bulb” temperature when input 2 is selected.
ATMPRES	590 to 800 mmHg	ATMOSPHERIC PRESSURE COMPENSATION – This prompt only appears if you select “YES” at “RELHUMID” prompt previously. Select the desired compensation.
DEVIATION	NONE SETPNT CHAN1	DEVIATION – selects deviation recording action. <ul style="list-style-type: none"> NONE – No deviation recording SETPNT – Records deviation from setpoint CHAN1 – Pen 1 records the difference between Input 1 and Input 2.
DEVSETPT	–999.0 to 9999	DEVIATION SETPOINT VALUE – sets the desired deviation setpoint value for deviation recording. <ul style="list-style-type: none"> This prompt only appears if “SETPNT” was selected at prompt “DEVIATION” previously.

Lower Display Prompt	Upper Display Range of Setting or Selection	Parameter Definition
SCROLL		LOWER DISPLAY SCROLL —The lower display will automatically change to the next item (as if the LOWR DISP key had been pressed) at the interval selected.
	NONE	NONE —Disables the scroll function.
	1 SEC	1 SEC —One second intervals
	2 SEC	2 SEC —Two second intervals
	3 SEC	3 SEC —Three second intervals
GRANDTOT	ENABLE DISABL	GRAND TOTALIZER —When enabled it prints, on the chart, the sum of ALL the enabled totalizers as TOTAL = XXXXXXXXXXXX.

4.14 Lockout Parameters Set Up Group

Introduction

These are the parameters that you will set to lockout any unauthorized changes to the recorder's configuration and calibration prompts.



ATTENTION

Configuration can also be locked using S1 switch on the main printed circuit board. Refer to *Subsection 2.9 – Configuration Lockout Switch*. The chart plate can be sealed using a lead seal to provide a positive indication that the electronics and configuration lockout switch may have been accessed.

Set this group last

Because this group contains functions that have to do with security and lockout, we recommend that you configure this group last, after all the other configuration data has been loaded.

Lockout group prompts

Table 4-14 lists all the function prompts in the Lockout set up group and their definitions.

Table 4-14 Lockout group definitions

Lower Display Prompt	Upper Display Range of Setting or Selection	Parameter Definition
LOCKOUT	NONE CALIB +CONF MAX	<p>LOCKOUT applies to one of the functional groups: Configuration, Calibration, Tuning, Adaptive Tune. DO NOT CONFIGURE UNTIL ALL CONFIGURATION IS COMPLETE.</p> <p>No Lockout – all groups read/write.</p> <p>CALIB – All are available for read/write except for the Calibration group.</p> <p>+CONF – Tuning, SP Ramp and program groups are read/write. All other groups are read only. Calibration group is not available.</p> <p>MAX – Calibration group not available. All other groups are Read-only.</p> <p>ATTENTION Do not leave in "NONE" Lockout.</p>

5. Operation

5.1 Overview

Introduction

This section gives you all the information necessary to monitor and operate your recorder and for performing routine maintenance tasks. In this section assume that the recorder has been properly installed and configured, and that the inputs are properly calibrated.

Some of the procedures in this section are required only initially, and some are required only randomly, as conditions dictate. Once the recorder is up and running, required operation actions are infrequent and straightforward.

Review the Operator Interface, Display and Keypad descriptions shown in *Section 1 Overview*.

What's in this section?

This section contains the following topics:

	Topic	See Page
5.1	Overview	117
5.2	Preparation	118
5.3	Start-up	120
5.4	Monitoring Your Recorder	123
5.5	Operator Functions	130
5.6	Operating Modes	131
5.7	Setpoints	133
5.8	Single Setpoint Ramp	135
5.9	Using Two Sets of Tuning Constants (PID Values)	138
5.10	Using Accutune II	141
5.11	Alarm Setpoints	144
5.12	Digital Input Option (Remote Switching)	145
5.13	Resetting and Displaying Totalizer Value	146
5.14	Monitoring the External Event Operation	148
5.15	Maximizing Pen Life	148
5.16	Routine Maintenance	149

5.2 Preparation

Introduction

After the DR4500A recorder is installed and configured, there are a few preparation tasks to perform prior to start-up. These tasks include:

- installing the chart,
- setting the time line, and
- changing the chart hub, if necessary.

Refer to Table 5-1 for these procedures.

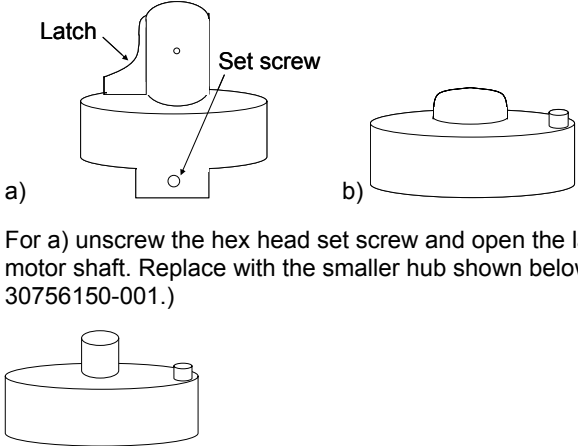
In some instances, it may be necessary to:

- tune the controller portion - see *Subsection 5.3 Start-up*,
- align the pens electrically - see *Section 9 Troubleshooting/Service*,
- recalibrate the input - see *Section 7 Input Calibration*.

Install/replace chart

Table 5-1 lists the steps required to install/replace the chart. Refer to Figure 5-1 and follow the procedure.

Table 5-1 Install/replace chart

Step	Action
1	Open the recorder door. Remove power if it is applied.
2	Pull the pen lifter up in order to raise the pen(s) from the chart.
3	If there is a chart already installed, remove the chart from the hub and retaining clips.
4	Install the new chart so that its edges are under the four retaining clips and its small alignment hole is over the alignment pin on the hub.
5	<p>• If your chart hub looks like one of these and requires a smaller hub size:</p>  <p>For a) unscrew the hex head set screw and open the latch. For a) and b): pull the hub off the motor shaft. Replace with the smaller hub shown below. (Use hub from Honeywell hub kit 30756150-001.)</p> <p>Continued</p>

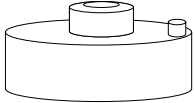
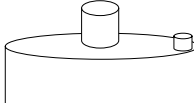
Step	Action
<p>5</p>	<ul style="list-style-type: none"> If your chart hub looks like this and requires a smaller hub size:  <p>then just pull the adapter hub off the chart hub to expose the smaller diameter hub.</p>  <p>Save the adapter hub for future use.</p>

Figure 5-1 shows the location of the basic recording components.

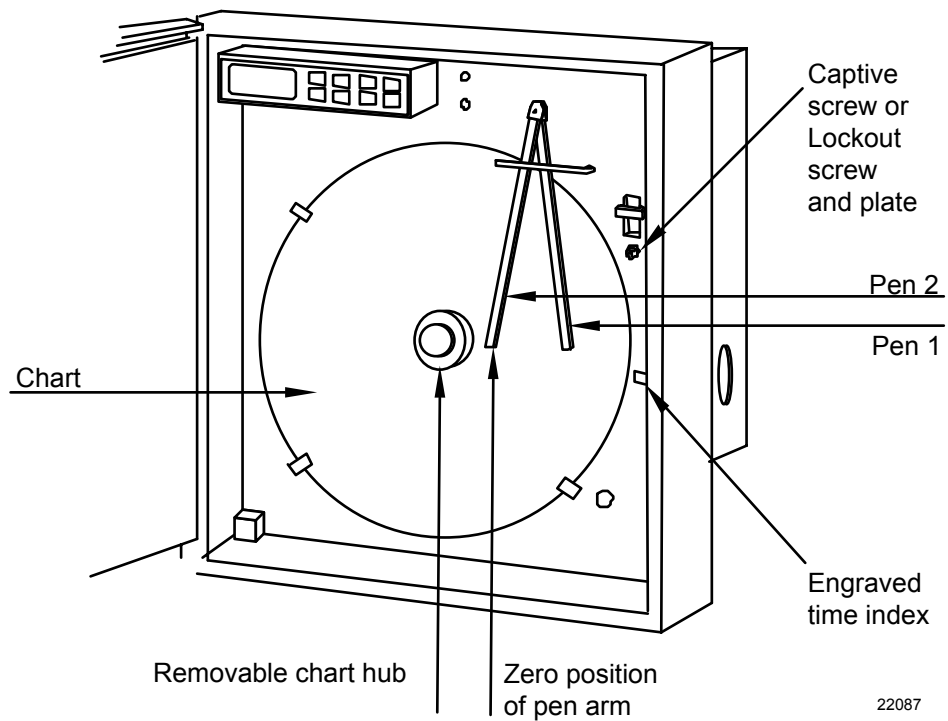


Figure 5-1 Basic recording components

Set the Chart Time Line

Table 5-2 lists the steps required to set the chart time line.

Table 5-2 Set the chart time line procedure

Step	Press	Action/Result
1		Apply power and wait until the recorder runs its power-up tests.
2	CHART	To enable the chart drive function.
	▲ or ▼	To drive the chart forward To drive the chart backward until current chart time line aligns with engraved time index on the chart plate. To increase forward drive speed, press and release the ▲ key while holding in the ▼ key.
3	CHART	To disable the chart drive function and return to normal operation.

5.3 Start-up

Preparation

Before start-up, there are two tasks to perform:

- Install or replace the circular chart as described in *5.16 Routine Maintenance*.
- Be sure that the configured settings for the current time and wake time (time at which recording begins) are correct. Note that the recorder is “awake” during start-up to verify interaction with the process.

During start-up, you should verify the interaction between your process and the DR4500A recorder to be sure that your process can tolerate some upsets during this procedure.

Diagnostic tests

When power is applied, the recorder will run four diagnostic tests. Table 5-3 lists the four diagnostic tests.

Table 5-3 Power up diagnostic tests

Prompt on Lower Display	Condition
RAM TEST	Check RAM
CONFTEST (configuration checksum)	Check nonvolatile memory
CAL TEST (working calibration)	Check calibration
BATTERY	Check the battery

Test failures

If control is enabled and one or more of these tests fail, the recorder will go to the Failsafe Manual Mode, and “FAILSAFE” will flash in the lower display.

If control is *not* configured, the self-test failures will be displayed periodically as other error messages are presently displayed (CNFG ERR, CAL1 ERR, CAL2 ERR, or BATT LOW).

Troubleshooting

Refer to “STATUS TESTS” in *Section 9 Troubleshooting/Service* to identify and correct the problem.

Check the displays and keys

Use the procedure in Table 5-4 to run the display and key test.

Table 5-4 Procedure for testing the displays and keys

Press	Result																		
<p style="text-align: center;">SET UP</p> <p style="text-align: center;">and hold in, then press</p> <p style="text-align: center;">FUNC</p> <p style="text-align: center;">at the same time</p>	<p>Release the keys. The recorder runs a display test. All the displays will light for 8 seconds, then you will see:</p> <p style="text-align: center;"><i>Upper Display:</i> KEYS</p> <p style="text-align: center;"><i>Lower Display:</i> TRY ALL</p>																		
<p>Press each key to see if it works</p>	<p>When the key is pressed, the lower display indicates the name of the key pressed.</p> <table border="1" data-bbox="727 1119 1300 1535" style="margin-left: auto; margin-right: auto;"> <thead> <tr> <th>Key Pressed</th> <th>Lower Display</th> </tr> </thead> <tbody> <tr> <td>SET UP</td> <td>SET UP</td> </tr> <tr> <td>FUNC</td> <td>FUNCTION</td> </tr> <tr> <td>LOWR DISP</td> <td>LWR DISP</td> </tr> <tr> <td>MAN/AUTO</td> <td>AUTO MAN</td> </tr> <tr> <td>CHART</td> <td>CHART</td> </tr> <tr> <td>▲</td> <td>INCRMENT</td> </tr> <tr> <td>▼</td> <td>DECRMENT</td> </tr> <tr> <td>RUN/HOLD</td> <td>RUN HOLD</td> </tr> </tbody> </table>	Key Pressed	Lower Display	SET UP	SET UP	FUNC	FUNCTION	LOWR DISP	LWR DISP	MAN/AUTO	AUTO MAN	CHART	CHART	▲	INCRMENT	▼	DECRMENT	RUN/HOLD	RUN HOLD
Key Pressed	Lower Display																		
SET UP	SET UP																		
FUNC	FUNCTION																		
LOWR DISP	LWR DISP																		
MAN/AUTO	AUTO MAN																		
CHART	CHART																		
▲	INCRMENT																		
▼	DECRMENT																		
RUN/HOLD	RUN HOLD																		

- If no key is pressed for 25 seconds, the test times out and the recorder exits the key test.
- If any test fails, go to *subsection 9.3 Self Diagnostics* for more information.

Key error

When a key is pressed and the prompt “KEY ERROR” appears in the lower display, it will be for one of the following reasons:

- parameter not available,
- not in Set Up mode, press **SET UP** key first,
- key malfunction, perform keyboard test.

Start-up procedure

Use the procedure listed in Table 5-5 to start up the recorder.

Open the recorder door. Apply power and wait for the recorder to run its power-up tests.



ATTENTION

- If FAILSAFE starts blinking in the lower display, refer to Section 9 for troubleshooting data.
- For recorders with two controllers (both enabled), be sure the CHN ‘1’ indication is lit for steps 2-6. If CHN 1 is not lit, sequentially press the **LOWR DISP** key until “1” is lit when “OUT” is displayed.

Table 5-5 Procedure for starting up the recorder

Step	Description	Press	Action
1	Pen check		For RECORDER ONLY models, just check that the pen is operating and skip to step 6.
2	Select manual mode	MAN AUTO	Until “MAN” indicator is ON. The recorder is in manual mode and the Output (OUT) in percent is displayed in the lower display.
3	Adjust the output	▲ or ▼	Adjust the output value and ensure that the final control element is functioning correctly. <i>Upper Display:</i> shows the PV value <i>Lower Display:</i> shows OUT and the output value in % Make sure the pen trace on the chart corresponds to the change in output.
4	Tune the recorder	SET UP	Make sure the recorder has been configured properly and all the values and selections have been recorded on the Configuration Record Sheet. To tune your recorder automatically, see section 5.10 <i>Using Accutune II</i> . Refer to Set Up group TUNING 1 or TUNING 2 to ensure that the proper selections for PROP BD or GAIN, RATE MIN, and RSET MIN or RSET RPM have been entered.

Step	Description	Press	Action
5	Enter the local setpoint	LOWR DISP	Until you see: <i>Upper Display:</i> shows the PV value <i>Lower Display:</i> SP and the local setpoint value
		▲ or ▼	Adjust the local setpoint to the value at which you want the process variable maintained. The local setpoint cannot be changed if the Setpoint Ramp function is enabled. “H” or “R” appears in the upper display.
6	Select automatic mode	MAN AUTO	Until “A” indicator is ON. The recorder is in Automatic mode. The recorder will automatically adjust the output to maintain the process variable at setpoint as tracked by the pen trace, if the recorder is properly tuned.
7	Start up Controller #2	LOWR DISP	Until “2” is lit when “OUT” is displayed. For recorders with two controllers (both enabled), repeat steps 2-6 for controller #2, but be sure CHN “2” indicator is lit instead of CHN “1”.
8	Exit Start-up		Close the door and monitor the operation.

5.4 Monitoring Your Recorder

Introduction

Besides the historical chart record, you can monitor the recorder’s indicators and displays to get an instantaneous view of various process conditions and of the control loop status.

Diagnostic error messages signal detection of malfunctions in certain internally monitored data. Alarm and tuning messages indicate alarms in effect and control loops being tuned.

Operator interface

The indicators and displays on the operator interface let you see what is happening to your process and how the recorder is responding.

Figure 5-2 is a view of the operator interface. A description of the displays and indicators is included.

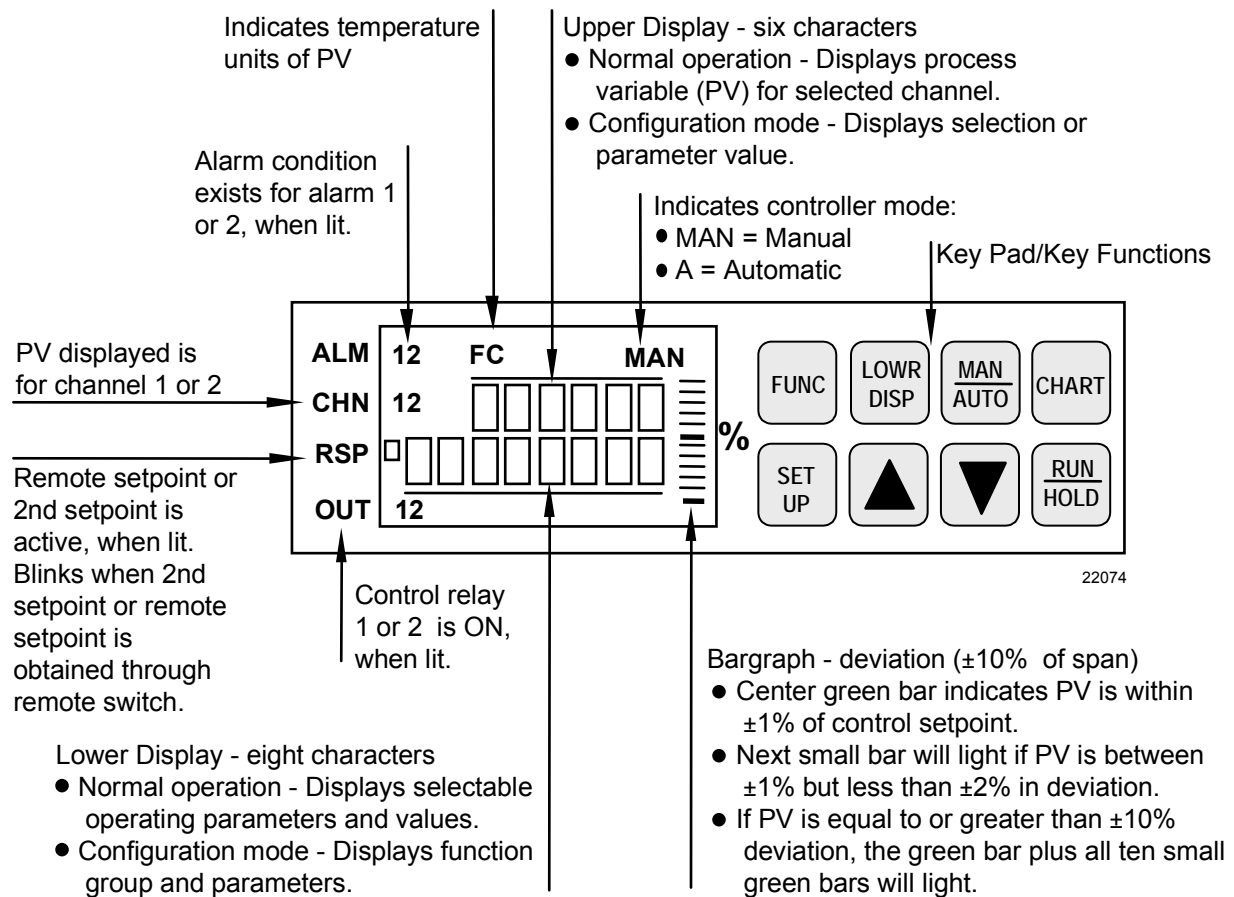


Figure 5-2 Operator interface

Meaning of indicators

During normal operation, the indicators will light for the reasons shown in Table 5-6.

Table 5-6 Meaning of indicators

Indicator	Definition when lit
ALM 1 2	Alarm condition exists for alarm 1 or 2.*
CHN 1 2	PV displayed is for channel 1 or 2.
RSP	Remote Setpoint (when available) or 2nd setpoint is active.
OUT 1 2	Control relay 1 or 2 is ON.
A or MAN	Indicates the mode of operation: A = Automatic MAN = Manual
F or C or blank	Indicates the temperature units of PV: F = Fahrenheit C = Celsius
R or H or G or blank (in upper display)	Indicates the state of the setpoint ramp or program if enabled: R = Run H = Hold G = Guar Soak blank = Disabled
T	Totalizer
LIMIT (in lower display)	Alternately displayed with limit SP value in lower display when limit condition exists.
KEY ERR (in lower display)	Indicates parameter not available, not in set up mode, or key malfunction.

* ALM1 indicator can also mean the Interval Timer has timed out. Alarms 3-6 are indicated by a message on the lower display. See Table 5-9.

Reading the deviation bargraph

In addition to the indicators, a bargraph containing 21 bars displays Process Variable (PV) deviation from Setpoint (SP).



ATTENTION

When CHN "1" indicator is lit, the bargraph display applies for Controller #1. It applies for Controller #2 when CHN "2" indicator is lit. Sequentially press the **LOWR DISP** key to light the appropriate CHN indicator (1 or 2) and view the corresponding controller displays.

- The green "on-control" bar lights when the PV is within $\pm 1\%$ of setpoint.
- The 10 small green bars above the "on-control" bar light for each positive deviation up to $+10\%$ and the 10 below light for each negative deviation down to -10% . If the process deviation is greater than $\pm 10\%$, the "on-control" bar and the specific small green bars light.

Figure 5-3 shows how the deviation bargraph works.

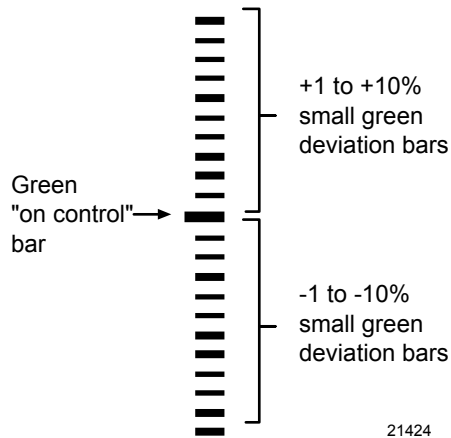


Figure 5-3 Deviation bargraph

Viewing the operating parameters

The upper display is a six-character display, four of which show the value of the PV during normal operation.

- The lower display is an eight-character display. During normal operation, you can view various operating parameters. Press the **LOWR DISP** key to scroll through the operating parameters listed in Table 5-7.
- The lower display shows only those parameters and their values that apply to your specific model and the way in which it was configured.
- You can configure the lower display to scroll through the items in Table 5-7 at an interval of 1, 2, or 3 seconds. Refer to *subsection 3.17 Options Set Up group, function prompt “SCROLL”* to make your selection.

Pressing the **LOWR DISP** key will freeze the lower display at the presently viewed item; pressing it again will advance to the next item and scrolling will resume.

- Pressing **▼** while pressing **LOWR DISP** will scroll backwards.

For recorders with two controllers (both enabled) remember that any controller-related values displayed correspond with the lighted CHN indicator — “1” means that the values apply for Controller #1 and “2” means that the values apply for Controller #2.

Table 5-7 Lower display key parameter prompts

Prompt	Description
OUT**	Output Value in Percent (%). Note that the output can only be adjusted through the raise/lower keys when the controller in manual mode.
SP**	Local Setpoint 1. Also current setpoint of SP Ramp or SP Ramp/Soak Program.
SPN	Current setpoint for setpoint rate applications.
2SP**	Local Setpoint 2 (where remote setpoint does not apply)
RSP	Remote Setpoint (when configured)
2IN	Value of Channel 2 input (when available)
DEV	PV deviation from setpoint (± 999.9 maximum)
EU	Engineering units that PV represents (when available)
RH	RH value in percent (%) (when available)
PIDSETx**	Tuning Parameter Set x = 1 or 2
RAMP	The time (minutes) remaining in the setpoint ramp
#RA	The time (minutes) remaining in the SP Ramp segment
#SK	The time (minutes) remaining in the SP Soak segment
RECYC	The number of recycles remaining to be run in the Setpoint Program
↓ □.□□ **	Time remaining in Timer function
↑ □.□□ **	Time elapsed in Timer function
TUNExXXX**	Accutune II indicator. x = Loop number (1 or 2). XXX = ON or OFF.

Prompt	Description
XXXXXX	Totalization value—upper display shows TCHN1 (or 2) for totalization value 1 (or 2).

**You can press ▲ or ▼ to change the value of this parameter.

Diagnostic error messages

The DR4500A runs background tests to verify data and memory integrity. If there is a malfunction, an error message will blink in the lower display. In the case of more than one simultaneous malfunction or alarm, each message will be shown in succession.

A list of error messages is contained in Table 5-8. If any of these error messages occur, refer to *Section 9 - Troubleshooting/Service* for information to correct the failure.

Table 5-8 Error messages

Prompt	Description
EE FAIL	Unable to write to nonvolatile memory
FAILSAFE	Failsafe
INP1FAIL	Two consecutive failures of input 1 integration
INP2FAIL	Two consecutive failures of input 2 integration
INP1 RNG INP2 RNG	Input out-of-range
PV LIMIT	PV $\pm 10\%$ out-of-range
RV LIMIT	Remote Variable out-of-range Note: RV = (input 2 x ratio) + bias
CNFG ERR	Configuration data is in error.
CAL1 ERR	Working CAL TEST failure (Control Output #1, Input 1, Input 2)
CAL2 ERR	Working CAL TEST failure (Control Output #2)
BATT LOW	Battery failure

Alarm and tuning messages

Alarms #3 through #6 and Accutune II for Control Loops #1 and #2 are indicated in the lower display.

In the case of more than one simultaneous diagnostic or alarm message, each message will be shown in succession.

Table 5-9 Alarm and tuning messages

Prompt	Description
ALARM 3	Indicates an alarm 3 action.
ALARM 4	Indicates an alarm 4 action.
ALARM 5	Indicates an alarm 5 action.
ALARM 6	Indicates an alarm 6 action.
TUNING 1	Indicates Accutune II in progress for Control Loop 1.
TUNING 2	Indicates Accutune II in progress for Control Loop 2.



ATTENTION

An active alarm will always provide an indication on the display but may not control its associated relay; that is, a higher priority function such as a control loop or timer may have control of the relay.

5.5 Operator Functions

Actions an operator can initiate

An operator can do the following:

- Change the Control Mode (Auto/Man)
- Adjust the Output Manually
- Change the Setpoint
- Switch between Setpoints
- Run or Disable a Setpoint Ramp
- Run or Disable a Setpoint Program
- Switch between Two Sets of PID Values
- Run or Disable Control Loop Tuning
- Check the Alarm Setpoints
- Display and Reset the Totalizer
- Close a Remote Switch
- Monitor External Event Pen Operation
- Run a Key Test

Note that some actions depend upon how the recorder was configured and the features supplied on your particular recorder model.

Refer to the following pages for functions and procedures.

CHN indicator

Remember, for recorders with two controllers (both enabled), any controller-related values displayed, including control mode, correspond with the lighted CHN indicator — “1” means that the values apply for Controller #1 and “2” means that the values apply for Controller #2. Sequentially press the **LOWR DISP** key to scroll through the displays and light the appropriate CHN indicator for controller-related values.

5.6 Operating Modes

Available modes

The recorder can operate in any of three basic modes:

- Manual
- Automatic with Local Setpoint
- Automatic with Remote Setpoint

Manual and Automatic with Local setpoint are standard features and Automatic with Remote Setpoint is optional.

Mode definitions

Table 5-10 Operating mode definitions

Operating Mode	Definition
MANUAL	When switched to manual mode, the recorder holds its output at the last value used during automatic operation and stops adjusting the output for changes in setpoint or process variable. Instead, you adjust the output by changing the value shown in the lower display. See "Selecting Modes".
AUTOMATIC with LOCAL SETPOINT	In automatic local mode, the recorder operates from the local setpoint and automatically adjusts the output to maintain the setpoint at the desired value. In this mode you can adjust the setpoint. See "Setpoints".
AUTOMATIC with REMOTE SETPOINT	In automatic remote mode, the recorder operates from the setpoint measured at input 2. Adjustments are available to ratio this input and add a constant bias before it is applied to the control equation. See subsection 3.10 Control Set Up Group.

What happens when you change modes

Table 5-11 explains what happens to the recorder when you switch from one mode to another.

Table 5-11 Changing operating modes

Operating Mode	Definition
Manual to Automatic Local Setpoint	The local setpoint is usually the value previously stored as the local setpoint.
Manual or Auto Local to Automatic Remote SP	The second input value with ratio and bias applied is used to calculate the control setpoint.
Automatic Remote SP to Manual or Auto Local Setpoint	If configured for RSP Tracking, when the recorder transfers out of remote setpoint, the last value of the control setpoint is inserted into the local setpoint. If RSP tracking is not configured, the local setpoint will not be altered when the transfer is made. See subsection 3.10 Control Set Up Group "SP TRACK".

Selecting manual or automatic mode

An alternate action switch places the recorder in automatic or manual mode of operation.

- Switching between manual and automatic will be bumpless, except when the PD+MR algorithm is selected.
- Table 5-12 includes procedures for selecting automatic or manual mode and changing the output while in manual.

Table 5-12 Procedure for selecting automatic or manual mode

Step	Operation	Press	Action/Result
1	Selecting automatic mode	MAN AUTO	<p>Until "A" indicator is ON. The recorder regulates its output to maintain the PV at the desired setpoint.</p> <p><i>Upper Display:</i> shows the PV value</p> <p><i>Lower Display:</i> shows SP and the setpoint value</p> <p>The deviation bargraph indicates the PV deviation from the setpoint.</p>
2	Selecting manual mode	MAN AUTO	<p>Until "MAN" indicator is ON. The recorder holds its output at the last value used during automatic operation and stops adjusting the output for changes in setpoint or process variable.</p> <p><i>Upper Display:</i> shows the PV value</p> <p><i>Lower Display:</i> shows OUT and the output value in %</p> <p>The deviation bargraph indicates the PV deviation from the setpoint.</p>
3	Adjust the output in manual mode	▲ or ▼	<p>Adjust the output value while in manual mode.</p> <p><i>Upper Display:</i> shows the PV value</p> <p><i>Lower Display:</i> shows OUT and the output value in %</p>
4	Return to automatic mode	MAN AUTO	"A" indicator appears indicating automatic mode.

5.7 Setpoints

Introduction

You can configure the following setpoints for the DR4500A recorder.

- A single local setpoint
- 2 local setpoints
- A local setpoint and a remote setpoint

These setpoints can be toggled by the **FUNC** key.

Selecting the setpoint source

Use the procedure in Table 5-13 to select a single local setpoint source, a remote setpoint source, or two local setpoints.

Table 5-13 Procedure for selecting the setpoint source

Step	Operation	Press	Action/Result
1	Enter set up mode	SET UP	Until the displays read: <i>Upper Display: SET UP</i> <i>Lower Display: CONTROL</i>
2	Display local setpoint source selections	FUNC	Until the displays read: <i>Upper Display: Setpoint source selections</i> 1LOCAL 2LOCAL REMOTE <i>Lower Display: SP SOURCE</i>
3	Select the desired source	▲ or ▼	Select the desired setpoint source in the upper display.
4	Return to control	LOWR DISP	Controller assumes normal control.

Changing the local setpoints

Use the procedure in Table 5-14 to change either local setpoint value.

Table 5-14 Procedure for changing the local setpoint

Step	Operation	Press	Action/Result
1	Select the setpoint	LOWR DISP	Until you see: <i>Upper Display: PV value</i> <i>Lower Display: SP or SP2 and the local setpoint value</i>
2	Change the value	▲ or ▼	Change the local setpoint to the value at which you want the process maintained. The deviation bargraph indicates PV deviation from setpoint.

Switching between setpoints

You can switch between Local and Remote setpoints or between two Local setpoints when configured. Use the procedure in Table 5-15 to switch between setpoints.

Table 5-15 Procedure for switching between setpoints

Step	Operation	Press	Action/Result
1	Switch between setpoints	FUNC or LOWR DISP	Alternately select Local setpoint 1 and Remote setpoint or switch between the 2 Local Setpoints. or Press appropriate key until you see the desired setpoint indicated. ATTENTION "KEY ERROR" appears in the lower display if the remote setpoint or second local setpoint is not configured as a setpoint source, or if you attempt to change the setpoint while a setpoint ramp is enabled.
2	Change the Local setpoint value	▲ or ▼	The REMOTE setpoint cannot be changed at the keyboard.

Setpoint selection indication

Table 5-16 shows how the indicators react and what the displays show for each type of setpoint.

Table 5-16 Setpoint selection indication

	Using Local Setpoint	Using Remote Setpoint	Using 2 nd Local Setpoint
RSP Indicator	OFF	ON (Note 1)	ON (Note 2) (Note 3)
Upper Display	PV	PV	PV
Lower Display	SP and the Local Setpoint Source	RSP and Remote Setpoint Value	2SP and the 2nd Local Setpoint Value
To Change Setpoint Value	Press ▲ or ▼	Cannot change the value at the keyboard.	Press ▲ or ▼

Note 1—RSP blinks when RSP is reached using Digital Input.

Note 2—RSP solid for 2nd Setpoint

Note 3—RSP blinks for 2nd setpoint activated by Digital Input.

5.8 Single Setpoint Ramp

Configuring the setpoint ramp

You can configure a single setpoint ramp to occur between the current local setpoint and a final local setpoint over a time interval of from 1 to 255 minutes. You can RUN or HOLD the ramp at any time.

Procedure

Table 5-17 lists the procedure for configuring the Setpoint Ramp 1 or 2 parameters. The procedure for **Setpoint Program** is in *Section 6 – Setpoint Ramp/Soak Programming Option*.

Table 5-17 Procedure for configuring a single setpoint ramp

Step	Operation	Press	Action/Result
1	Select SP RAMP 1 or SP RAMP 2 Set Up group	SET UP	Until you see: <i>Upper Display: SET UP</i> <i>Lower Display: SP RAMP X</i> X = 1 or 2
2	Select the Setpoint Ramp function	FUNC	Until you see: <i>Upper Display: DISABL</i> <i>Lower Display: SP RAMP X</i>
3	Enable Setpoint Ramp	▲	Until you see: <i>Upper Display: ENABLE</i> <i>Lower Display: SP RAMP X</i> NOTE: You cannot change the current local setpoint if the setpoint ramp function is enabled. Make sure SP PROG is disabled.
4	Set the Ramp Time	FUNC	Until you see: <i>Upper Display: The ramp time in minutes</i> <i>Lower Display: TIME MIN</i>
		▲ or ▼	Change the upper display value to the number of minutes in which you want the final setpoint to be reached. Setting Range = 1 to 255 minutes NOTE: Entering "0" implies an immediate step change to the final SP.
5	Set the Final Setpoint value	FUNC	<i>Upper Display: The final setpoint value</i> <i>Lower Display: FINAL SP</i>
6		▲ or ▼	Change the upper display value to the desired final setpoint value. Setting Range = within the setpoint limits

Running the setpoint ramp

Running a setpoint ramp includes starting, holding, viewing the ramp time, ending the ramp and disabling it.

Procedure

Table 5-18 lists the procedure for running the setpoint ramp.

Table 5-18 Procedure for running a setpoint ramp

Step	Operation	Press	Action/Result
1	Put the controller into automatic mode	MAN AUTO	Until "A" indicator is ON and you will see: <i>Upper Display: H</i> and the PV value <i>Lower Display: SP</i> and the present setpoint value
2	Set Start SP	▲ or ▼	Until the start setpoint value you desire is indicated in the lower display: <i>Upper Display: H</i> and the PV value <i>Lower Display: SP</i> and the start setpoint value
3	Start the ramp	RUN HOLD	You will see: <i>Upper Display: R</i> and the PV value <i>Lower Display: SP</i> and a changing setpoint value NOTE: The value in the lower display will be increasing or decreasing toward the final setpoint value. The PV value in the upper display and the pen trace will also change.
4	Hold the ramp at the current value	RUN HOLD	This holds the ramp at the current setpoint value. Press again to continue run. A "KEY ERROR" prompt appears if RUN/HOLD key is pressed while "SP RAMP" is disabled.
5	View the remaining ramp time	LOWR DISP	Until you see: <i>Upper Display: R</i> or <i>H</i> and the PV value <i>Lower Display: RAMP XXXM</i> (time remaining)
6	End the ramp		When the final setpoint is reached, the "R" changes to "H" in the upper display and the recorder operates at the new setpoint. ATTENTION Any time the local setpoint is different from the final setpoint value and the RUN/HOLD key is pressed, the ramp will start again.

Step	Operation	Press	Action/Result
7	Disable the setpoint ramp function	SET UP	Until you see: <i>Upper Display: SET UP</i> <i>Lower Display: SP RAMP X</i>
		FUNC	You will see: <i>Upper Display: ENABLE</i> <i>Lower Display: SP RAMP X</i>
		▲	You will see: <i>Upper Display: DISABL</i> <i>Lower Display: SP RAMP X</i>
8	Return to normal operating mode	LOWR DISP	Returns to normal operating mode.

5.9 Using Two Sets of Tuning Constants (PID Values)

Introduction

You can use two sets of tuning constants for single output types and choose the way they are to be switched.

The sets can be:

- Keyboard selected
- Automatically switched when a predetermined Process Variable value is reached.
- Automatically switched when a predetermined Setpoint value is reached.

The following procedures show you how to:

- Select two sets
- Set the switchover value
- Set tuning constant value for each set
- Switch between two sets via the keyboard (without automatic switchover)



ATTENTION

For recorders with two controllers (both enabled) remember that any controller-related values displayed correspond with the lighted CHN indicator — “1” means that the values apply for Controller #1 and “2” means that the values apply for Controller #2.

Select two sets

The procedure in Table 5-19 tells you how to select two sets of tuning constants.

Table 5-19 Procedure for selecting two sets of tuning constants

Step	Operation	Press	Action/Result
1	Select Control Set Up group	SET UP	Until you see: <i>Upper Display:</i> SET UP <i>Lower Display:</i> CONTROL
2	Select PID SETS function	FUNC	You will see: <i>Upper Display:</i> Available selections are— 1 ONLY – 1 set of constants 2 KEYBD – 2 sets, keyboard selectable 2 PVSW – 2 sets, auto switch at PV value 2 SPSW – 2 sets, auto switch at SP value <i>Lower Display:</i> PIDSETS
		▲ or ▼	Select the type of PID set.

Set switchover value

If you select 2 PVSW or 2 SPSW, you must set a value at which the sets will switch over.

The procedure in Table 5-20 shows you how to set this value.

Table 5-20 Procedure for setting switchover values

Step	Operation	Press	Action/Result
1	Select switchover value function	FUNC assuming you are still in Set Up group CONTROL	Until you see: <i>Upper Display:</i> The switchover value <i>Lower Display:</i> SW VALUE
		▲ or ▼	Select the switchover value in the upper display.

Set Tuning constant values for each set

There are specific tuning constants that must be set for each set. The procedure in Table 5-21 shows you how to access these constants and change their values.

Table 5-21 Procedure for setting tuning constant values

Step	Operation	Press	Action/Result
1	Select Tuning Set Up group	SET UP	Until you see: <i>Upper Display:</i> SET UP <i>Lower Display:</i> TUNING
2	Select the tuning constants	FUNC	Successively displays the following constants: <i>Upper Display:</i> Tuning constant value <i>Lower Display:</i> PROPBD or GAIN* RATEMIN* RSETMIN or RSETRPM* PROPBD2 or GAIN2** RATE2MIN** RSET2MIN or RSET2RPM** *PIDSET1 – will be used when PV or SP, whichever is selected, is greater than the switchover value. **PIDSET2 – will be used when PV or SP, whichever is selected, is less than the switchover value.
		▲ or ▼	Change the value of any of the above listed prompts in the lower display.

Switch between two sets via the keyboard (without automatic switchover)

This procedure is operational only if 2 PID SETS was configured at “CONTROL” set up group.

The procedure in Table 5-22 shows you how to switch from one set to another.

Table 5-22 Procedure for switching PID sets from the keyboard

Step	Operation	Press	Action/Result
1	Access the PID set display	LOWR DISP	Until you see: <i>Upper Display:</i> The PV value <i>Lower Display:</i> PIDSETX X = 1 or 2
		▲ or ▼	Change PIDSET1 to PIDSET2 or vice versa.

5.10 Using Accutune II

Introduction

Accutune II provides foolproof, trouble-free on-demand tuning in the recorder. No knowledge of the process is required at start-up. The operator simply enters the desired setpoint and initiates the tuning. The recorder immediately starts controlling to the setpoint while it identifies the process, calculates the tuning constants and enters them into the tuning set up group, and begins PID control with the correct tuning parameters. This works with any process, including integrating type processes, and allows retuning at a fixed setpoint. The tuning sequence will cycle the recorder's output two full cycles between 0% and 100% (or low and high output limits) while allowing only a very small process variable change above and below the setpoint during each cycle.

- Accutune works for all control algorithms except ON/OFF.
- The recorder must be in Auto mode.
- Accutune works for integrating processes.

Enable/disable Accutune using the Tuning Set Up group TUNE parameter described in Section 4.

Detailed instructions for using Accutune follow.

Starting and Stopping Tuning with Accutune II

After "TUNE" has been enabled in the tuning set up group as described in Section 4, use the procedure in Table 5-23 to start tuning.

To abort tuning in progress, press the **MAN/AUTO** key to take the recorder out of Auto mode. The message "AbRT" (abort) will be displayed as the value of tuning set up group parameter "AT ERR". The tuning parameters will retain the values they had at the start of the Accutune operation.

Table 5-23 Procedure for starting Accutune II

Step	Press	Action/Result
1	DISP	Until you see <i>Lower Display:</i> TUNExOFF x = 1 or 2 If "TUNExOFF" (tune off) does not appear, then Accutune is not enabled.
2	▲ or ▼	to toggle to <i>Lower Display:</i> TUNExON x = 1 or 2 Tuning will begin and the lower display will flash "TUNING". When tuning has been completed the lower display will again show "TUNExOFF".

Using Accutune with Duplex (Heat/Cool) Control

“TUNE” can be done for applications using Duplex (Heat/Cool) control.

During tuning, Accutune II assumes SP 1 will cause a Heating demand, and then the calculated tuning parameters will be automatically entered as the first set of PID constants. Likewise, it assumes tuning at Local SP 2 will cause a Cooling demand, and the cooling parameters will be entered as the second set of PID constants.

Procedure

After “TUNE” has been enabled in the Tuning Set Up group as described in section 4, use the procedure in Table 5-24 to start tuning. Note that control group parameter “SP SOURC” must be set to “2LOCAL” to enable the second setpoint.

To abort tuning in progress, press the **MAN/AUTO** key to take the recorder out of Auto mode. The message “AbRT” (abort) will be displayed as the value of Tuning Set Up group parameter “AT ERR”. The tuning parameters will retain the values they had at the start of the Accutune operation.

Table 5-24 Procedure for using Accutune for duplex control

Step	Press	Action/Result
Heating Tuning		
1	DISP	Until you see Setpoint 1. <i>Lower Display: SP nnn</i>
2	▲ or ▼	Until the value of Setpoint 1 is at the desired value within the Heat zone. Make sure the recorder is in Auto mode. (“A” indicator lit.) If not, use the MAN/AUTO key to put the unit in Auto.
3	DISP	Until you see <i>Lower Display: UseSPn</i> This is the prompt used to select the setpoint. If it is not “USESP1”, use ▲ or ▼ to switch to “USESP1”.
4	DISP	Until you see <i>Lower Display: TUNExOFF</i> x = 1 or 2 If “TUNExOFF” (tune off) does not appear, then Accutune is not enabled.
5	▲ or ▼	to toggle to <i>Lower Display: TUNExON</i> x = 1 or 2 Tuning will begin and the lower display will flash “TUNING”. The output will cycle between 50% and 100% (or high output limit). When tuning has been completed the lower display will again show “TUNExOFF”. The Heat tuning parameters are entered for the first set of PID constants in the Tuning Set Up group.

Step	Press	Action/Result
Cooling Tuning		
6	DISP	Until you see Setpoint 2. <i>Lower Display: SP nnn</i>
7	▲ or ▼	Until the value of Setpoint 2 is at the desired value within the Cooling zone.
8	DISP	Until you see <i>Lower Display: Use SP1</i>
9	▲ or ▼	to toggle to <i>Lower Display: Use SP2</i>
10	DISP	<i>Lower Display: TUNExOFF</i> x = 1 or 2
11	▲ or ▼	to toggle to <i>Lower Display: TUNExON</i> x = 1 or 2 Tuning will begin and the lower display will flash "TUNING". The output will cycle between 0% and 50% (or low output limit). When tuning has been completed the lower display will again show "TUNExOFF". The Cool tuning parameters are entered for the second set of PID constants in the Tuning Set Up group.

5.11 Alarm Setpoints

Introduction

- An alarm consists of a relay contact and an operator interface indication. The alarm relay is de-energized if Alarm Setpoint 1 or Setpoint 2 is exceeded.
- The alarm relay is energized when the monitored value goes into the allowed region by more than the hysteresis.
- There are twelve alarm setpoints, two for each alarm.
- The type and state (High or Low) is selected during configuration: see *Section 3 - Configuration* for details.



ATTENTION

An active alarm will always provide an indication on the display but may not control the relay; that is, a higher priority function such as a control loop or timer may have control of the relay.

Procedure for displaying the alarm setpoints

The procedure for displaying and changing the alarm setpoints is listed in Table 5-25.

Table 5-25 Procedure for displaying or changing the alarm setpoints

Step	Operation	Press	Action/Result
1	Access the Alarm Set Up group	SET UP	Until you see: <i>Upper Display:</i> SET UP <i>Lower Display:</i> ALARM X X = 1, 2, 3, 4, 5, 6
2	Access the Alarm Setpoint Values	FUNC	Successively displays the alarm setpoints and their values. <i>Upper Display:</i> The alarm setpoint value <i>Lower Display:</i> AXS1 VAL – Setpoint 1 value of alarm 1, 2, 3, 4, 5, or 6 AXS2 VAL – Setpoint 2 value of alarm 1, 2, 3, 4, 5, or 6
		▲ or ▼	Change any alarm setpoint value you select in the upper display.
3	Return to normal operation	LOWR DISP	Returns to normal operation.

5.12 Digital Input Option (Remote Switching)

Introduction

The digital input option detects the state of external contacts wired to it. On contact closure, the recorder responds according to how each digital input is configured.

- Make your selection under Set Up group “CONTROL1” or “CONTROL2”, function group prompt “REM SW”: see *Subsection 3.10—Table 3-7* or *Subsection 4.6—Table 4-5*.

Action on contact closure

Table 5-26 lists the configuration prompt selections, the “Action on Contact Closure”, and the display indication for each selection available.

Table 5-26 Digital input option action on contact closure

REM SW Selections	Display Indication	Action on Contact Closure
None	None	No Digital Input selection
To MAN	“MAN” blinks	Puts the recorder into manual mode; contact open returns the recorder to former mode unless AUTO/MAN key is pressed while digital input is active.
To LSP	“RSP” blinks	Puts the recorder into local setpoint 1 (switches out of remote). When contact opens, the recorder returns to former operation unless the FUNC key is pressed while digital input is active.
To 2SP	“RSP” blinks	Puts the recorder into local setpoint 2.
To DIR	None	Selects direct controller action (transfer if in reverse).
RN/HOLD	“H” blinks in upper display	Suspends setpoint program or setpoint ramp. <ul style="list-style-type: none"> • Keyboard takes priority over external switch for RUN/HOLD function. • Contact open runs the program or ramp. • If initially in the HOLD state, close then open the contact to remotely start the SP ramp or program.
TUNE	TUNING x	Initiates Accutune.

Keyboard operation

If a particular mode or parameter is selected by the contact closure, using the keyboard to select the same parameter ensures that the selected mode will be maintained after the remote digital switch is reopened.

5.13 Resetting and Displaying Totalizer Value

Introduction

If the totalizer is enabled and has been configured to allow resetting, you can reset the current totalizer value as follows.

- Refer to *Section 3 - Configuration*, under Set-up prompt “TOTAL 1” for Input #1 or “TOTAL 2” for Input #2 to enable the totalizer function and allow the totalizer to be reset.
- Refer to the procedures that follow to:
 - reset the totalizer locally,
 - reset the totalizer externally (switch),
 - display the totalizer value.

Resetting the totalizer

Follow the procedure in Table 5-27 to reset the totalizer value.

Table 5-27 Procedure for resetting the totalizer

Step	Operation	Press	Action/Result
1	Access the Totalizer Set Up group	SET UP	Until you see: <i>Upper Display: SET UP</i> <i>Lower Display: TOTAL 1 or TOTAL 2</i>
2	Allow Totalizer Reset	FUNC once	You will see: <i>Upper Display: Ex XXX</i> <i>Lower Display: (a value)</i>
		FUNC again	You will see: <i>Upper Display: NO</i> <i>Lower Display: RSET TOT</i>
		▲ or ▼	Change NO to YES in the upper display. ATTENTION Function prompt “RSETABLE” must be set to “LOCAL”.
3	Return to normal operation	LOWR DISP	Returns to normal operation.

External totalizer reset

The totalizer can be reset to “0” from external switch #1 or external switch #2. Refer to *Subsection 3.9 – Totalizer Set Up Group* and set function prompt “RSETABLE” to “EXT SW1” or “EXT SW2”.

Displaying the totalizer value

Follow the procedure in Table 5-28 to display the totalizer value.

Table 5-28 Procedure for displaying the totalizer value

Step	Operation	Press	Action/Result
1	Alternating Totalizer Display	LOWR DISP	<p>Until you see:</p> <p style="text-align: center;"><i>Upper Display: tPV VALUE</i> <i>Lower Display: (total value)</i></p> <div style="border: 1px solid black; padding: 2px; display: inline-block;">ATTENTION</div> When two totalizers are configured, notice that channels #1 and #2 totalizer values are alternately displayed.
2	Display Channel #1 totalizer	▲ or ▼	<p>Until CHN "1" indicator lights.</p> <p style="text-align: center;"><i>Upper Display: 1tPV VALUE</i> <i>Lower Display: (total value) (8 digits maximum)</i></p>
3	Display Channel #2 totalizer	▲ or ▼	<p>Until CHN "2" indicator lights.</p> <p style="text-align: center;"><i>Upper Display: 2tPV VALUE</i> <i>Lower Display: (total value) (8 digits maximum)</i></p>
4	Return to Alternating Display	▲ and ▼ simultaneously	<p>You will see:</p> <p style="text-align: center;"><i>Upper Display: SCAN</i> <i>Lower Display: (total value) (8 digits maximum)</i></p> <p>After the keys are released, the upper display alternately shows #1, #2 PV values while lower display shows #1, #2 totalization values.</p>
5	Return to Normal PV Display	LOWR DISP	Returns to normal PV display.

5.14 Monitoring the External Event Operation

Event pen function

If Function prompt “PEN IIN” under Set-up prompt “PEN 1” has been configured as DGTL1 or DGTL2, the pen (channel) operates as an “event pen” and tracks the remote contact (switch) closure by way of the digital 1 or digital 2 input wired to the alarm output/digital input printed circuit board.

Event pen operation

When the switch opens, the pen for the channel tracks at the configured OFF position (0-100%) on the chart.

When the switch closes, the pen tracks at the configured ON position (0-100%) on the chart and tracks at this position until the switch is opened.

Thus, the “Event Pen” record makes it easy to monitor the on/off operation of an external event.

5.15 Maximizing Pen Life

Steps for maximizing pen life

Table 5-29 lists nine steps that will help to maximize the life of your chart pen.

Table 5-29 Maximizing pen life

Step	Action
1	Store the chart paper in a cool, clean dry place where the temperature does not exceed 40°C (104°F) and the humidity is below 65% RH.
2	Do not expose the pen tip and chart paper to abrasive chemicals or dust that cause excessive pen wear.
3	If the recorder is used in a dusty atmosphere, provide a positive ‘clean air purge’ to minimize dust particle accumulation on the chart paper.
4	Periodically clean the pen arm using a cotton swab dipped in alcohol. This is more important when the recorder is located in a dusty environment and no ‘clean air purge’ is used.
5	Never let the pen tip ride on the chart plate when the paper is not present. Use the pen lifter to raise the arm when changing the paper.
6	Keep the door closed while recording.
7	Always insert the pen arm tip into the shipping sponge when storing or shipping the recorder.
8	Be sure that the chart paper lays flat against the chart plate. Any ripple in the paper will cause light pen printing.
9	Be sure the chart hub assembly is pushed onto the motor shaft so that it is flush with the chart plate.

5.16 Routine Maintenance

Introduction

The DR4500A recorder does not require any periodic maintenance as such. But you will have to replace the ink cartridge, and replace the chart and optional chart lamp, as required.



CAUTION

Do not lubricate the plastic gears on the chart and pen motors.

Changing the ink cartridge

Follow the procedure in Table 5-30 to clean the pen tip.



CAUTION

Be careful not to move the pen arm(s) during this procedure. The top arm is pen 1 (purple cartridge) and the bottom arm is pen 2 (red cartridge).

Table 5-30 Changing the ink cartridge

Step	Action
1	Open the recorder door.
2	Pull the pen lifter up in order to raise the pen from the chart.
3	Unclip and remove the ink cartridge from the pen arm.
4	Remove the protective cap from the pen tip on the new cartridge and open its clip.
5	Slide the new cartridge onto the pen arm and close its clip.
6	Push the pen lifter down to lower the pen tips to the chart.
7	Close the door and resume normal operation.

Replacing a burned-out chart lamp (optional)

Follow the procedure in Table 5-31 to replace a burned-out chart lamp.

Table 5-31 Replacing a chart lamp

Step	Action
1	Open the recorder door and remove power.
2	Unscrew and remove the hood from the lamp assembly.
3	Push the (bayonet-type) lamp in and turn it counterclockwise to remove it from the socket.
4	Reverse step 3 and install the replacement lamp (General Instrument type 1828 or equivalent) in the socket.
5	Replace the hood on the lamp assembly.
6	Close the door and apply the power.

5.17 Installing/Replacing Chart

Installing/replacing chart procedure

Follow the procedure in Table 5-1 to install/replace the chart.



CAUTION

Store replacement charts in a dust-resistant location. Otherwise, accumulated dust on the chart may cause excessive pen tip abrasion which can shorten expected pen life. In addition, you may want to air purge the case if the recorder is mounted in an extremely dusty environment.

6. Setpoint Ramp/Soak Programming and Operation

6.1 Overview

Introduction

As an option, the recorder can support the programming of a 36-segment setpoint program containing 18 ramp segments and 18 soak segments. In a ramp segment the setpoint value is changed as specified during configuration. The ramp is configured in terms of ramp time or ramp rate, depending on how you have configured the RAMPUNIT parameter. During a soak segment the setpoint is held at the specified value.

For each control loop you can build up to 6 profiles using any number of consecutive segments of the program.

Odd-numbered segments are always ramp segments. Even-numbered segments are always soaks. These ramp and soak segments can be used in up to six programs. You designate the beginning and end segments to determine where the program will start or stop.

- Every profile must start with a ramp segment and end on a soak segment.
- Control Loop must have Setpoint Source set to ILOCAL.
- Control Loop 1 uses SP RAMP1, Control Loop 2 uses SP RAMP2. SP RAMP1 and SP RAMP2 are the prompts under which the setpoint program is configured.
- Recorder must be set to use SP1 (setpoint 1).
- Only contiguous segments can be used by a profile.
- There can be overlap between programs. For example, Profile 1 could use Segments 1, 2, 3, 4, 5, and 6. Profile 2 could be configured to begin with Segment 5 and end with Segment 8.

This section contains instructions for setting up a setpoint program, and for executing the program at runtime.

Note that Section 4 contains instructions for using the setpoint ramp or setpoint rate. **The SPRAMP (setpoint ramp) and SPRATE (setpoint rate) parameters described in Section 4 must be set to DISABL (disabled) if a setpoint program is to be used.**



ATTENTION

If power is lost during execution of a program, upon power-up the recorder will use the last setpoint value prior to the beginning of the setpoint program. The program is placed in hold at the beginning. The Manual/Auto mode will be as configured under "POWER UP" in the "CONTROL" group.

What's in this section?

This section contains the following information:

Topic	See Page
6.2 Setpoint Program Contents	153
6.3 Drawing a Ramp/Soak Profile	156
6.4 Entering the Setpoint Program Data	161
6.5 SP RAMP1 and SP RAMP2 Set Up Group	163
6.6 Setpoint Program Profiles Set Up Group	165
6.7 Setpoint Program Segments Set Up Group	167
6.8 Setpoint Program Event Set Up Group	170
6.9 Run/Monitor the Program	174

6.2 Setpoint Program Contents

What you will configure

You will configure all the data that is relevant to each ramp and soak segment for a given setpoint versus time program (profile). The recorder will prompt you through the sequence of segments and associated functions. These prompts and functions are described below.

Recycle number

The recycle number allows the program to recycle a specified number of times from beginning to end.

- Range = 0 to 99

Guaranteed soak

A SOAK DEV (soak deviation) parameter is provided. If its value is not zero, then soaking will be frozen for each segment until the difference (plus or minus) between PV and SP is less than or equal to the value of SOAK DEV.

There are no guaranteed soaks whenever SOAKDEV = 0. In this case, soak segments start timing soak duration as soon as the soak setpoint is first reached, regardless of where the process variable remains relative to the soak setpoint during the duration of the segment.

The decimal location corresponds to input 1 decimal selection.

Profile number

The profile number specifies which of up to six profiles will run. Up to 6 profiles can be configured out of any even number of consecutive segments from the 36 segments configured.

Program state

The program state selection determines the program state after completion.

The selections are:

- DISABL = program is disabled
- HOLD = program on hold

Recovery

If Recovery is enabled the setpoint program will continue from where it left off after the last power down.

Program End State

This determines the status of the recorder upon completion of the profile. The selections are:

- LAST SP = hold at the last setpoint in the program
- F SAFE = Manual mode, Failsafe Output

Profile Start and Profile End

These selections let you specify the segments that will comprise each of the 6 profiles. The first segment must be a ramp (odd-numbered segment) and the last segment must be a soak (even-numbered).

Ramp unit

The ramp unit selection determines the engineering units for the ramp segments.

The selections are:

- TIME = Hours:Minutes
- EU-H = Degrees/Hour OR EU-M = Degrees/Minute

Ramp time or rate segments

A ramp segment is used to change the setpoint to the next soak setpoint value in the program.

- Ramps are odd-numbered segments. Segment 1 will be the initial ramp.
- Ramps are specified in terms of either:

TIME* - Hours:Minutes Range = 0-99 hrs:59 min.

or

EU-M* - Degrees/Minute Range = 0 to 999

EU-H* - Degrees/Hour

* *The selection of time or rate is made at prompt "RAMP UNIT"*

Set this prompt before entering any Ramp information.



ATTENTION

Entering "0" will imply an immediate step change in setpoint to the next soak.

Soak segments

A soak segment is a combination of soak setpoint (value) and a soak duration (time).

- Soaks are even-numbered segments.
- Segment 2 will be the initial soak value and soak time.
- The soak setpoint range value must be within the setpoint high and low range limits in engineering units. (Specify the setpoint range with SP HI and SP LO in the control group as described in Section 4.)
- Soak time is the duration of the soak and is determined in:

TIME - Hours:Minutes Range = 0-99 hrs:59 min.

Segment Events

Each segment can be programmed to trigger an alarm which in turn deenergizes the associated relay. The selected alarm must be programmed as an event type for this to occur. Selections are:

ALARM 1 – ALARM 6.

Segment events will not trigger a relay if that relay is configured with one of these higher priority functions:

- Control loop output
- Interval timer
- Alarm type other than “Event”.

See Table 6-7.

Digital input (remote) operation

Program can be placed in RUN or HOLD state through a remote dry contact connected to optional digital input terminals. The Control Loop parameters REM SW and REM SW2 parameters must be configured as RN/HLD to support this function. The valid states of the contacts are:

- RUN—contact closure places program in HOLD state
- HOLD—contact open places program in RUN state

6.3 Drawing a Ramp/Soak Profile

Ramp/soak profile example

Before you perform the actual configuration, we recommend that you draw your Ramp/Soak profiles in the space provided on the blank graphs and fill in the associated information on the worksheet. An example of a Ramp-Soak Profile using the first twelve segments for Profile 1 is shown in Figure 6-1. Start setpoint in this example is at 200 °F. Assume each soak segment is desired to trigger an event. Assume you are configuring the program to be used by Control Loop1 (SP RAMP1).

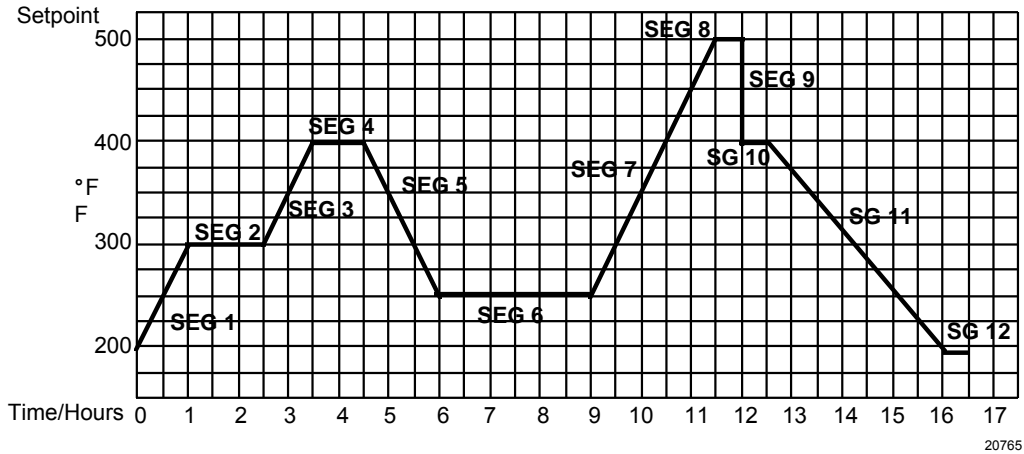


Figure 6-1 Ramp/Soak profile example

Table 6-1 Parameter settings for example 12-step profile

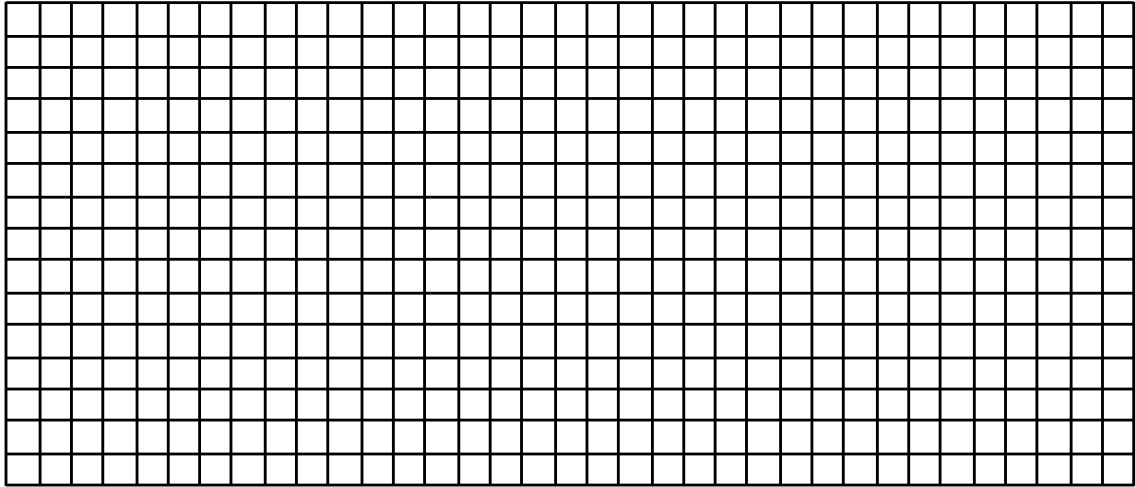
Prompt	Function	Segment	Value	Prompt	Function	Segment	Value
SP RAMP1	Settings for Control Loop 1 ramp			SEG7RAMP	Ramp	7	2hr.:30min.
SP PROG	Enables SP prompts.		ENABLE	SEG8 SP	Soak SP	8	500
RECYCLES	Number of Recycles		2	SEG8TIME	Soak Time	8	0hr.:30 min.
SOAK DEV	Deviation Value		0	SEG9RAMP	Ramp	9	0
PROFILE	Number of profile to run		1	SEG10 SP	Soak SP	10	400
STATE	Program State at end		HOLD	SG10TIME	Soak Time	10	0hr.:30 min.
RECOVERY	Program resumes after power interruption		ENABLE	SG11RAMP	Ramp	11	3hr.:30min.
PROG END	SP value after last segment		LAST SP	SEG12 SP	Soak SP	12	200
SPP SEGS	Settings for segments			SEG12TIME	Soak Time	12	0hr.:30 min.
PR1 STRT	Profile 1 Start Seg.		1	SEG1 EV	Event	1	NONE
PR1 END	Profile 1 End Seg.		12	SEG2 EV	Event	2	ALARM1
RAMPUNIT	Ramp Units		TIME	SEG3 EV	Event	3	NONE
SEG1 RAMP	Ramp	1	1 hr.	SEG4 EV	Event	4	ALARM1
SEG2 SP	Soak SP	2	300	SEG5 EV	Event	5	NONE
SEG2TIME	Soak Time	2	1hr.:30 min.	SEG6 EV	Event	6	ALARM1
SEG3RAMP	Ramp	3	1hr.	SEG7 EV	Event	7	NONE
SEG4 SP	Soak SP	4	400	SEG8 EV	Event	8	ALARM1
SEG4TIME	Soak Time	4	1 hr.	SEG9 EV	Event	9	NONE
SEG5RAMP	Ramp	5	1hr.:30 min.	SEG10 EV	Event	10	ALARM1
SEG6 SP	Soak SP	6	250	SEG11 EV	Event	11	NONE
SEG6TIME	Soak Time	6	3hr.:0min.	SEG12 EV	Event	12	ALARM1

Reminder: There are up to 36 segments available for inclusion in a profile. The above example uses only the first 12.

Profile graphs

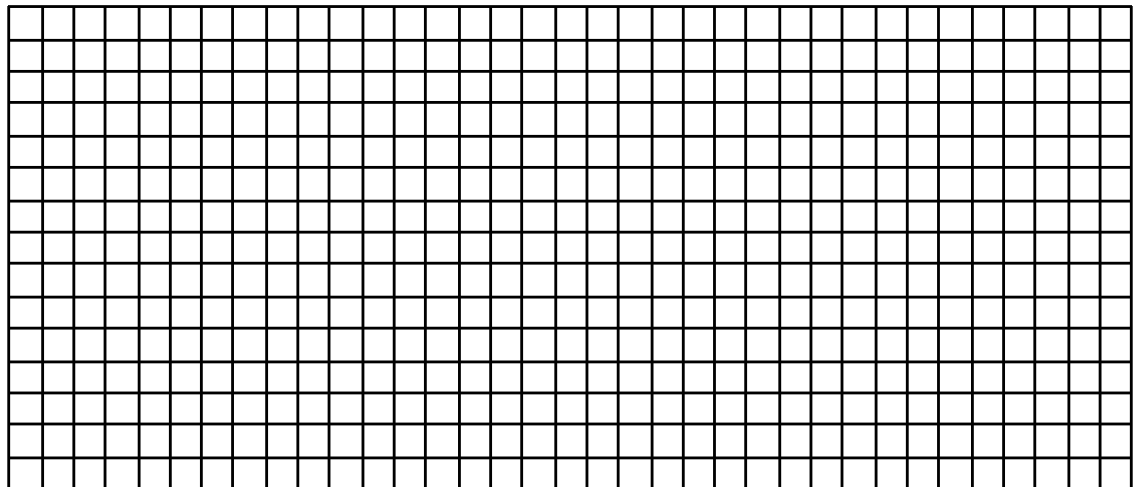
Draw your six ramp/soak profiles on the graphs below and fill in the associated information in the worksheets that follow in the next sections. This will give you a permanent record of your program and will assist you when entering the ramp and soak values.

Profile 1



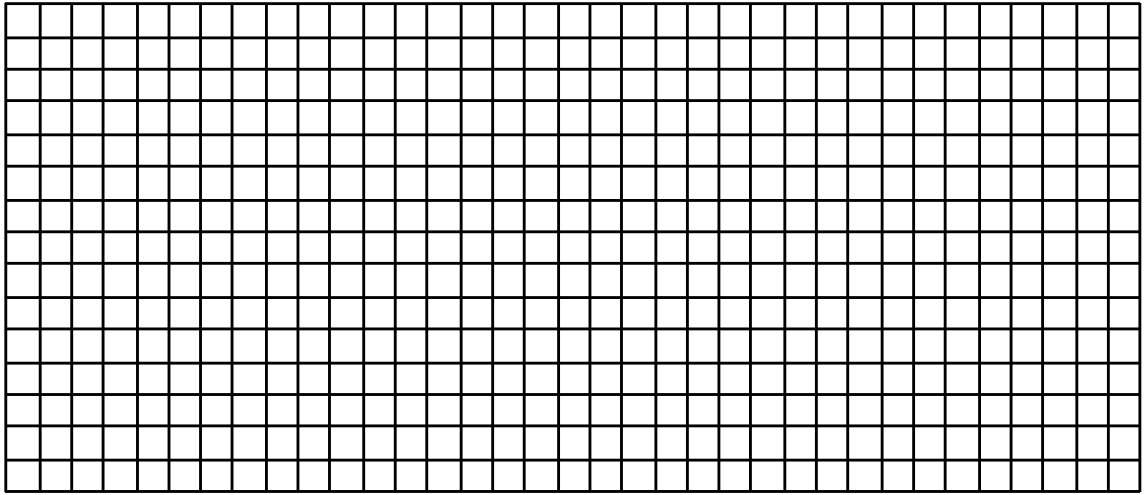
20766

Profile 2



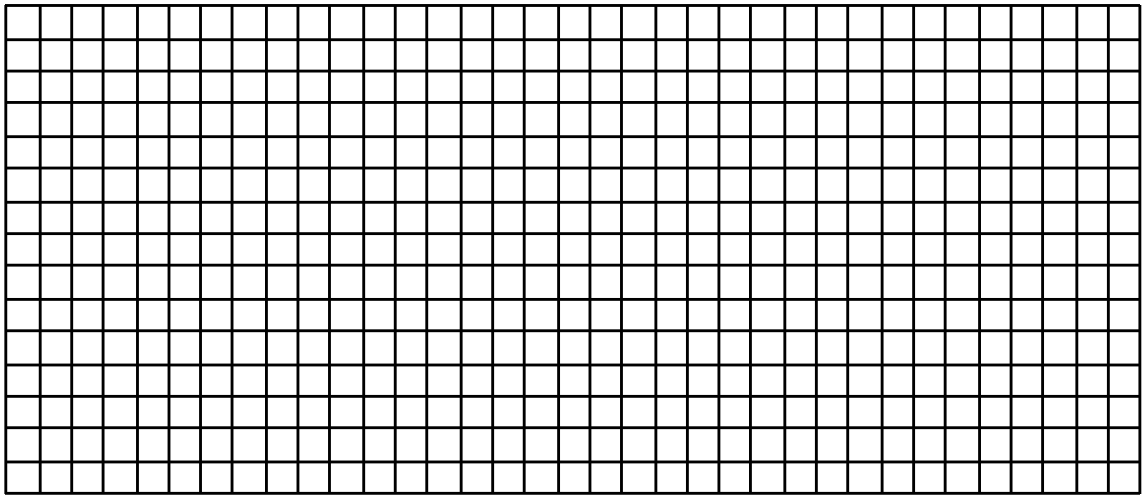
20766

Profile 3



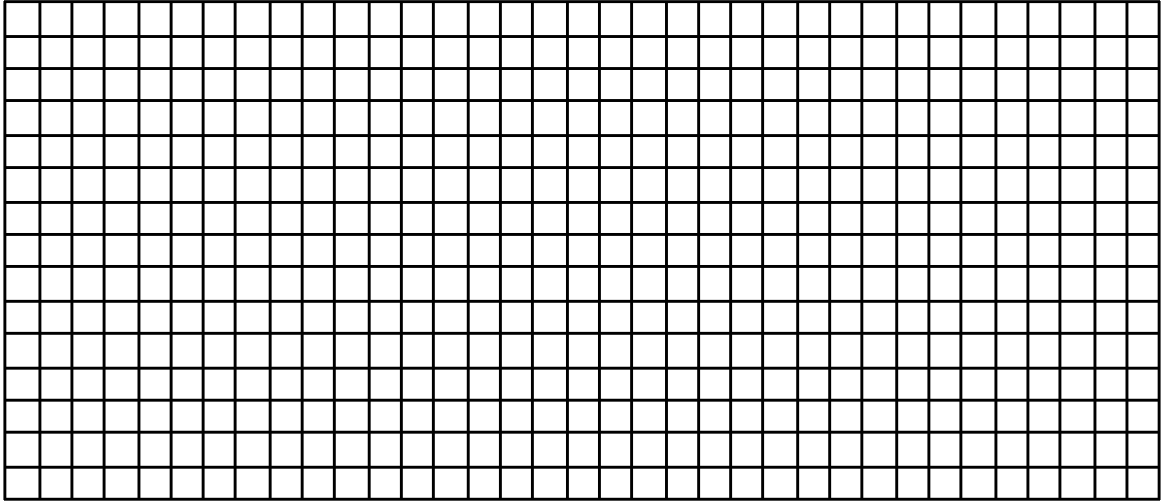
20766

Profile 4



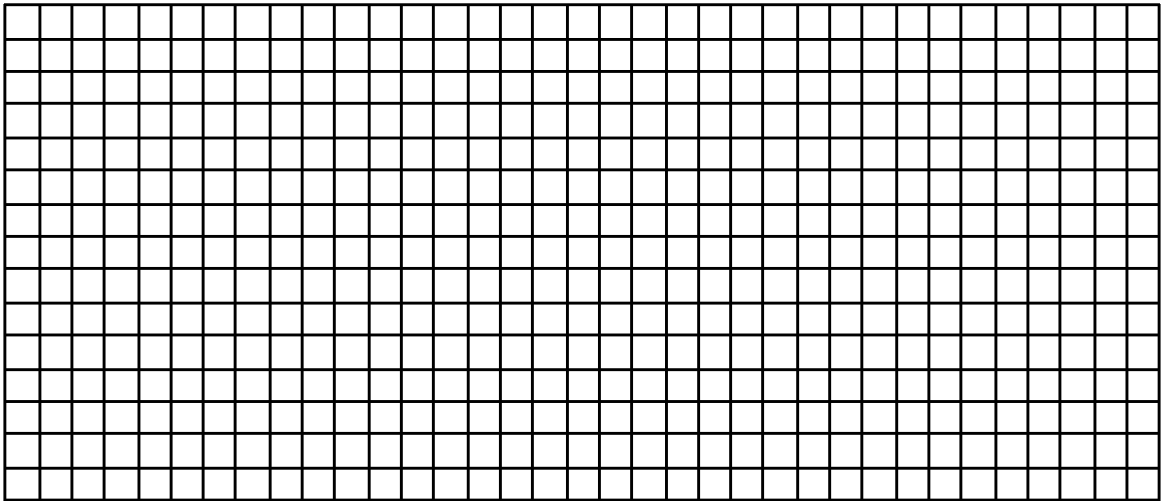
20766

Profile 5



20766

Profile 6



20766

6.4 Entering the Setpoint Program Data

Introduction

The procedure listed in Table 6-2 tells you what keys to press and what prompts you will see when entering the setpoint program data. Follow the prompts in Sections 6.5, 6.6, and 6.7 when selecting the functions for setpoint programming.



ATTENTION

Make sure SP RAMP and SP RATE are disabled first.

Table 6-2 Setpoint program data entry procedure

Step	Operation	Press	Action/Result
1	Select SP PROG Group	SET UP	Until you see: <i>Upper Display: SET UP</i> <i>Lower Display: SP RAMP_n n = 1 or 2</i>
2	Access SP PROG	FUNC	Until you see: <i>Upper Display: DISABL</i> <i>Lower Display: SP PROG</i> If you see <i>Upper Display: ENABLE</i> <i>Lower Display: SP RAMP</i> or <i>Upper Display: ENABLE</i> <i>Lower Display: SP RATE</i> you must disable them; SP PROG and its subordinate prompts are not visible unless SP RAMP and SP RATE are disabled. Once they are disabled, press FUNC until you see SP PROG.
3	Enable SP PROG	▲ or ▼	Until you see: <i>Upper Display: ENABLE</i> <i>Lower Display: SP PROG</i>
4	Select the functions	FUNC	<i>Upper Display: shows current value for each prompt</i> <i>Lower Display: shows individual function prompts within the setpoint program group</i> <ul style="list-style-type: none"> • Successive presses of the FUNCTION key sequentially displays all the functions and their values or selections. • Using the FUNCTION key, follow the prompts shown in Sections 6.5, 6.6, and 6.7.

Step	Operation	Press	Action/Result
5	Change the value or selection of a function prompt	▲ or ▼	This changes the value or selection in the upper display. If the display blinks, you are trying to select an unacceptable value.
6	Enter value or selection into memory	FUNC	This enters the value or selection and goes to another prompt. <ul style="list-style-type: none">• Repeat steps 4 and 5 for each function you want to change.
7	Exit configuration	LOWR DISP	This exits from the configuration mode.

6.5 SP RAMP1 and SP RAMP2 Set Up Group

Introduction

There is a SP RAMP set up group for each control loop. Use the prompts to select the settings for each loop's program.

SP RAMP Prompts

Table 6-3 lists all the function prompts for SP RAMP configuration in the order of their appearance. These prompts are available when SP PROG is enabled in the S PRAMP set up group described in Section 4.

All parameters may be changed while the program is disabled or in HOLD.

Table 6-3 SP RAMP prompts and available selections

Lower Display Prompt	Upper Display Range of Setting or Selection	Parameter Definition
SPPROG	DISABL ENABLE	SETPOINT PROGRAMMING —This must be set to ENABLE for the setpoint program feature to work, and for the associated operating parameters to be displayed. SP RAMP and SP RATE must be disabled. (See Section 4.) DISABL —Disables Setpoint Programming ENABLE —Enables Setpoint Programming
RECYCLES	0 to 99	RECYCLES —Enter the number of times the program selected for execution will be repeated.
SOAKDEV	–99.9 to 99.9 engineering units	SOAK DEVIATION —Enter the acceptable deviation from setpoint during a soak cycle. If the PV differs from the setpoint by more than the value of SOAKDEV, soak time is frozen. There are no guaranteed soaks if SOAKDEV = 0.
PROFILE	1 to 6	PROFILE used by Setpoint Program. This can also be set or changed when viewed in the lower display and the current profile is in the HOLD state.
STATE	DISABLE HOLD	Determines the state of the program after it completes the final program segment cycles. If you select DISABL, you must enable the program through the function prompt before you can run the program again. If you select HOLD, you can run the program again by pressing the RUN/HOLD key.
RECOVERY	ENABLE DISABL	This mode, when enabled, will allow the SP Program to continue from the point at which the power was removed when there is a power interruption.
PROG END	ENABLE DISABL	Determines the status of the control output after the program is run. If you select LASTSP, the recorder controls to the last setpoint value which becomes the LSP. For FSAFE selection, the recorder is switched to manual mode and to the selected failsafe output value.

SP RAMP1 and SP RAMP2 worksheet

Use this worksheet to make a record of your SP RAMP1 and SP RAMP2 settings.

Prompt	Description	Range	Your selection
SP RAMP1	Accesses prompts for Control Loop 1's profile	N/A	N/A
SP PROG	Enables SP Program prompts.	ENABLE DISABLE	ENABLE
RECYCLES	Number of Recycles	0-99	
SOAK DEV	Deviation Value	0.0-99	
PROFILE	Number of profile to run	1-6	
STATE	Program State at end	DISABL HOLD	
RECOVERY	Program resumes after power interruption	ENABLE DISABLE	
PROG END	SP value after last segment	LASTSP FSAFE	
SP RAMP2	Accesses prompts for Control Loop 2's profile	N/A	N/A
SP PROG	Enables SP Program prompts.	ENABLE DISABLE	ENABLE
RECYCLES	Number of Recycles	0-99	
SOAK DEV	Deviation Value	0.0-99	
PROFILE	Number of profile to run	1-6	
STATE	Program State at end	DISABL HOLD	
RECOVERY	Program resumes after power interruption	ENABLE DISABLE	
PROG END	SP value after last segment	LASTSP FSAFE	

6.6 Setpoint Program Profiles Set Up Group

Introduction

You can configure up to six profiles; each profile contains a subset of the 36 segments. Each profile starts with a ramp segment and ends with a soak segment. Each control loop uses one of these profiles. They can use the same profile, too. The profiles can be synchronized to RUN/HOLD together.

Setpoint program profiles group prompts

Table 6-4 lists all the function prompts in the Setpoint Program Profiles setup group and their definitions.

Table 6-4 Setpoint program profiles group definitions

Lower Display Prompt	Upper Display Range of Setting or Selection	Parameter Definition
PRx STRT	RAMP1 – RAMP 35	You can configure up to 6 profiles (PR1 – PR6). Each profile contains a subset of the 36 ramp and soak segments configured later. PRx STRT designates the number of the first segment of the profile. It must be a ramp segment (odd number).
PRx END	SOAK2 – SOAK36	This designates the number of the last segment of the profile. It will be a soak segment (even number).
RAMPUNIT	TIME (Hours:Minutes) EU/MIN (Engineering Units/Minute) EU/HR (Engineering Units/Hour)	This determines the engineering units for the ramp segments.
SYNC 1+2	ENABLE DISABL	Synchronizes the profiles for Control Loops 1 and 2. This means that: a) Both SP programs will RUN or HOLD simultaneously. b) A Guaranteed Soak Hold on one profile will cause the other profile to HOLD for the duration of the Guaranteed Soak Hold.

Setpoint program profiles worksheet

Use this worksheet to keep a record of your setpoint program profile settings.

Prompt	Description	Range	Your selection
PROFILES	Settings for profiles	NA	NA
PR1 STRT	Start Segment for Program 1	RAMP1 to RAMP35	
PR1 END	End Segment for Program 1	SOAK2 to SOAK36	
PR2 STRT	Start Segment for Program 2	RAMP1 to RAMP35	
PR2 END	End Segment for Program 2	SOAK2 to SOAK36	
PR3 STRT	Start Segment for Program 3	RAMP1 to RAMP35	
PR3 END	End Segment for Program 3	SOAK2 to SOAK36	
PR4 STRT	Start Segment for Program 4	RAMP1 to RAMP35	
PR4 END	End Segment for Program 4	SOAK2 to SOAK36	
PR5 STRT	Start Segment for Program 5	RAMP1 to RAMP35	
PR5 END	End Segment for Program 5	SOAK2 to SOAK36	
PR6 STRT	Start Segment for Program 6	RAMP1 to RAMP35	
PR6 END	End Segment for Program 6	SOAK2 to SOAK36	
RAMPUNIT	Ramp Type	TIME EU/MIN EU/HR	
SYNC 1+2	Synchronizes Profile for Control Loops 1 and 2	ENABLE DISABL	

6.7 Setpoint Program Segments Set Up Group

Introduction

You can configure up to 36 ramp and soak segments.

Setpoint program segments group prompts

Table 6-5 lists all the function prompts in the Setpoint Program Segments setup group and their definitions.

Table 6-5 Setpoint program segments group definitions

Lower Display Prompt	Upper Display Range of Setting or Selection	Parameter Definition
SEGxRAMP (x = 1, 3, 5,...35)	0-99 hrs:59 min. (Time) 0 to 999 (Rate)	A ramp segment is the time it takes to change the setpoint to the next setpoint value in the program. <ul style="list-style-type: none"> • Ramps are odd number segments. Segment #1 will be the initial ramp time. • This selection of time or rate is made at prompt "RAMPUNIT". ATTENTION: Entering "0" implies an immediate step change in setpoint to the next soak.
SEGx SP (x = 2, 4, 6...36)	Within the setpoint high and low range limits in engineering units	The soak segment's setpoint value
SEGxTIME (x = 2, 4, 6...36)	0-99 hrs:59 min.	The soak segment's duration.

Setpoint program segments worksheet

Use this worksheet to keep a record of your setpoint segment settings.

Prompt	Function	Range	Your selection	Prompt	Function	Range	Your selection
SPP SEGS	Settings for segments	NA	NA	SG13RAMP	Ramp	00.00 to 99.59 or 0 to 999	
SEG1RAMP	Ramp	00.00 to 99.59 or 0 to 999		SEG14SP	Soak SP	Within SP limits	
SEG2 SP	Soak SP	Within SP limits		SG14TIME	Soak Time	00.00 to 99.59	
SEG2TIME	Soak Time	00.00 to 99.59		SG15RAMP	Ramp	00.00 to 99.59 or 0 to 999	
SEG3RAMP	Ramp	00.00 to 99.59 or 0 to 999		SEG16SP	Soak SP	Within SP limits	
SEG4 SP	Soak SP	Within SP limits		SG16TIME	Soak Time	00.00 to 99.59	
SEG4TIME	Soak Time	00.00 to 99.59		SG17RAMP	Ramp	00.00 to 99.59 or 0 to 999	
SEG5RAMP	Ramp	00.00 to 99.59 or 0 to 999		SEG18SP	Soak SP	Within SP limits	
SEG6 SP	Soak SP	Within SP limits		SG18TIME	Soak Time	00.00 to 99.59	
SEG6TIME	Soak Time	00.00 to 99.59		SG19RAMP	Ramp	00.00 to 99.59 or 0 to 999	
SEG7RAMP	Ramp	00.00 to 99.59 or 0 to 999		SEG20SP	Soak SP	Within SP limits	
SEG8 SP	Soak SP	Within SP limits		SG20TIME	Soak Time	00.00 to 99.59	
SEG8TIME	Soak Time	00.00 to 99.59		SG21RAMP	Ramp	00.00 to 99.59 or 0 to 999	
SEG9RAMP	Ramp	00.00 to 99.59 or 0 to 999		SEG22SP	Soak SP	Within SP limits	
SEG10SP	Soak SP	Within SP limits		SG22TIME	Soak Time	00.00 to 99.59	
SG10TIME	Soak Time	00.00 to 99.59		SG23RAMP	Ramp	00.00 to 99.59 or 0 to 999	
SG11RAMP	Ramp	00.00 to 99.59 or 0 to 999		SEG24SP	Soak SP	Within SP limits	
SEG12SP	Soak SP	Within SP limits		SG24TIME	Soak Time	00.00 to 99.59	
SG12TIME	Soak Time	00.00 to 99.59		SG25RAMP	Ramp	00.00 to 99.59 or 0 to 999	

Prompt	Function	Range	Your selection	Prompt	Function	Range	Your selection
SEG26SP	Soak SP	Within SP limits		SG31RAMP	Ramp	00.00 to 99.59 or 0 to 999	
SG26TIME	Soak Time	00.00 to 99.59		SEG32SP	Soak SP	Within SP limits	
SG27RAMP	Ramp	00.00 to 99.59 or 0 to 999		SG32TIME	Soak Time	00.00 to 99.59	
SEG28SP	Soak SP	Within SP limits		SG33RAMP	Ramp	00.00 to 99.59 or 0 to 999	
SG28TIME	Soak Time	00.00 to 99.59		SEG34SP	Soak SP	Within SP limits	
SG29RAMP	Ramp	00.00 to 99.59 or 0 to 999		SG34TIME	Soak Time	00.00 to 99.59	
SEG30SP	Soak SP	Within SP limits		SG35RAMP	Ramp	00.00 to 99.59 or 0 to 999	
SG30TIME	Soak Time	00.00 to 99.59		SEG36SP	Soak SP	Within SP limits	
				SG36TIME	Soak Time	00.00 to 99.59	

6.8 Setpoint Program Event Set Up Group

Introduction

Segment events are used to activate relays by means of alarms. There are six alarms and six corresponding relays. Alarm 1 controls Relay 1, Alarm 2 controls Relay 2, etc. When the setpoint program reaches the segment, the segment event triggers the alarm which triggers the relay. The relay stays on for the duration of the segment. There are no alarm conditions to be satisfied, that is, when the event goes on the alarm goes on.

How to trigger a relay with a segment event

1. Program the segment event with the alarm corresponding with the desired relay.
2. Program that alarm as type EVENT. It is not necessary to program any alarm parameters other than the alarm type.
3. Do not program other functions that have higher priority control of the relay. See Table 6-7.

Setpoint Program Event group prompts

Table 6-6 lists all the function prompts in the Setpoint Program Event setup group and their definitions.

Table 6-6 Setpoint program event group definitions

Lower Display Prompt	Upper Display Range of Setting or Selection	Parameter Definition
SEGx EV (x = 1-36)	NONE ALARM1, ALARM2, ALARM3, ALARM4, ALARM5, ALARM6	Configured event will be active during the segment. All others will be inactive.

Example of how a segment event works

For example, to have Segment 1 energize Relay 1:

- Program SEG1 EV as ALARM1.
- Program A1S1TYPE or A1S2TYPE as EVENT.
- Do not program the Timer function Relay 1; namely, Timer.

For alarm programming information, see section 4.10.

To ensure control of relay by segment event

To make sure a segment event operates the associated relay, observe the requirements below.

Table 6-7 Segment event relay operation requirements

Relay	Relay is controlled by (in order of priority)	Requirements for operation of relay by segment event
1	<ol style="list-style-type: none"> 1. Timer function 2. Alarm 1 	<ul style="list-style-type: none"> • Do not configure Timer. • Configure Alarm 1 type Event.
2	Alarm 2	Configure Alarm 2 type Event.
3	<ol style="list-style-type: none"> 1. Controller 1 output algorithms Relay Simplex, Position Proportional, Relay Duplex, Current/Relay Duplex 2. Alarm 3 	<ul style="list-style-type: none"> • Do not configure Controller #1 with these output algorithms. • Configure Alarm 3 type Event.
4	<ol style="list-style-type: none"> 1. Controller 1 output algorithms Position Proportional, Relay Duplex, Current/Relay Duplex 2. Alarm 4 	<ul style="list-style-type: none"> • Do not configure Controller #1 with these output algorithms. • Configure Alarm 4 type Event.
5	<ol style="list-style-type: none"> 1. Controller 2 output algorithms Relay Simplex, Position Proportional, Relay Duplex, Current/Relay Duplex 2. Alarm 5 	<ul style="list-style-type: none"> • Do not configure Controller #2 with these output algorithms. • Configure Alarm 5 type Event.
6	<ol style="list-style-type: none"> 1. Controller 2 output algorithms Position Proportional, Relay Duplex, Current/Relay Duplex 2. Alarm 6 	<ul style="list-style-type: none"> • Do not configure Controller #2 with these output algorithms. • Configure Alarm 6 type Event.

Setpoint program event worksheet

Use this worksheet to make a record of the segment event settings.

Prompt	Description	Range	Your selection
SPP EVNT	Access to events	N/A	N/A
SEG1 EV	Event status	NONE ALARM1 ALARM2 ALARM3 ALARM4 ALARM5 ALARM6	
SEG2 EV	Event status	Same	
SEG3 EV	Event status	Same	
SEG4 EV	Event status	Same	
SEG5 EV	Event status	Same	
SEG6 EV	Event status	Same	
SEG7 EV	Event status	Same	
SEG8 EV	Event status	Same	
SEG9 EV	Event status	Same	
SEG10 EV	Event status	Same	
SEG11 EV	Event status	Same	
SEG12 EV	Event status	Same	
SEG13 EV	Event status	Same	
SEG14 EV	Event status	Same	
SEG15 EV	Event status	Same	
SEG16 EV	Event status	Same	
SEG17 EV	Event status	Same	
SEG18 EV	Event status	Same	
SEG19 EV	Event status	Same	
SEG20 EV	Event status	Same	
SEG21 EV	Event status	Same	
SEG22 EV	Event status	Same	
SEG23 EV	Event status	Same	
SEG24 EV	Event status	Same	
SEG25 EV	Event status	Same	
SEG26 EV	Event status	Same	

Prompt	Description	Range	Your selection
SEG27 EV	Event status	Same	
SEG28 EV	Event status	Same	
SEG29 EV	Event status	Same	
SEG30 EV	Event status	Same	
SEG31 EV	Event status	Same	
SEG32 EV	Event status	Same	
SEG33 EV	Event status	Same	
SEG34 EV	Event status	Same	
SEG35 EV	Event status	Same	
SEG36 EV	Event status	Same	

6.9 Run/Monitor the Program

Introduction

Make sure all the “SP PROG” function prompts under the Set Up group “SP RAMP” have been configured with the required data.

- An “H” appears in the upper display indicating that the program is in the HOLD state. If an “H” does not appear, go to the SP Program configuration procedure and enable the program instead of disabling.



ATTENTION

For recorders with two controllers (both enabled), remember that any controller-related values displayed correspond with the lighted CHN indicator. “1” means that the values apply for Controller #1 and “2” means that the values apply for Controller #2.

Run/Monitor functions

Table 6-8 lists all the functions required to run and monitor the program.

Table 6-8 Run/Monitor functions

Function	Press	Result
Run State	RUN HOLD	Initiates the setpoint program. “H” changes to “R” in the upper display indicating that the program is running. PV value and pen trace tracks the ramp soak profile.
Hold State	RUN HOLD	Holds the setpoint program. <ul style="list-style-type: none"> • An “H” appears in the upper display indicating that the program is in the HOLD state. • The setpoint holds at the current setpoint. Press again to continue to run.
External Hold		If Remote Switching (Digital Input Option) is present on your recorder, contact closure places the recorder in the HOLD state, if the setpoint program is running. <ul style="list-style-type: none"> • The “H” in the upper display blinks. <div style="border: 1px solid black; padding: 2px; display: inline-block;">ATTENTION</div> The keyboard takes priority over external switch for the RUN/HOLD function. <ul style="list-style-type: none"> • Contact reopening runs program.
Guaranteed Soak		If a non-zero value has been entered for SOAK DEV, a Soak Segment will be suspended until deviation (SP-PV) is less than SOAK DEV. <ul style="list-style-type: none"> • A “G” will appear in the upper display during Soak Deviation Hold.

Function	Press	Result																											
Viewing the present ramp or soak segment number and time	LOWR DISP	<p>Until you see:</p> <p><i>Upper Display:</i> R and the PV value</p> <p><i>Lower Display:</i></p> <p>For Ramp segments:</p> <p># RA XX.XX</p> <table border="0"> <tr> <td> </td> <td> </td> <td>Ramp Time - Hours:Minutes or</td> </tr> <tr> <td> </td> <td> </td> <td>Ramp Rate - Degrees/Minute</td> </tr> <tr> <td> </td> <td> </td> <td>Indicates Ramp segment</td> </tr> <tr> <td> </td> <td> </td> <td>Segment Number (odd only)</td> </tr> </table> <p>For Soak segments:</p> <p># SK XX.XX</p> <table border="0"> <tr> <td> </td> <td> </td> <td>Time remaining in segment in</td> </tr> <tr> <td> </td> <td> </td> <td>Hrs:Minutes including current</td> </tr> <tr> <td> </td> <td> </td> <td>partially completed minute</td> </tr> <tr> <td> </td> <td> </td> <td>Indicates Soak segment</td> </tr> <tr> <td> </td> <td> </td> <td>Segment Number (even only)</td> </tr> </table>			Ramp Time - Hours:Minutes or			Ramp Rate - Degrees/Minute			Indicates Ramp segment			Segment Number (odd only)			Time remaining in segment in			Hrs:Minutes including current			partially completed minute			Indicates Soak segment			Segment Number (even only)
		Ramp Time - Hours:Minutes or																											
		Ramp Rate - Degrees/Minute																											
		Indicates Ramp segment																											
		Segment Number (odd only)																											
		Time remaining in segment in																											
		Hrs:Minutes including current																											
		partially completed minute																											
		Indicates Soak segment																											
		Segment Number (even only)																											
Skipping segments	LOWR DISP	<p>Until you see:</p> <p><i>Upper Display:</i> R and the PV value</p> <p><i>Lower Display:</i> #RA XX.XX (Ramp Segment) #SK XX.XX (Soak Segment)</p>																											
	RUN HOLD	<p>To hold the SP Program</p> <ul style="list-style-type: none"> An "H" appears in the upper display indicating that the program is in the HOLD state. 																											
	▲ or ▼	To select new segment																											
	RUN HOLD or LOWR DISP	<p>To begin running at new segment</p> <p>To retain the old segment</p>																											
Viewing the number of cycles left in the program	LOWER DISP	<p>Until you see:</p> <p><i>Upper Display:</i> R and the PV value</p> <p><i>Lower Display:</i> RECYC XX Remaining cycles 0 to 99 This number includes the current partially completed cycle.</p>																											
End Program		<p>When the final segment is completed, the "R" in the upper display either changes to "H" if configured for HOLD state, or disappears if configured for DISABL of setpoint programming.</p> <ul style="list-style-type: none"> The recorder operates at the last setpoint in the program in automatic or will be in manual mode at the failsafe output. 																											

7. Input Calibration

7.1 Overview



SHOCK HAZARD—WARNING!

Disregard of these instructions may cause injury or death.

INPUT CALIBRATION MAY REQUIRE ACCESS TO HAZARDOUS LIVE CIRCUITS, AND SHOULD ONLY BE PERFORMED BY QUALIFIED SERVICE PERSONNEL. MORE THAN ONE SWITCH MAY BE REQUIRED TO DE-ENERGIZE UNIT BEFORE CALIBRATION.

Introduction

This section describes the field calibration procedures for inputs 1 and 2. All DR4500A recorders are factory calibrated prior to shipment. It should not, therefore, be necessary to recalibrate the recorder when it is initially installed. However, you must recalibrate the input if any one of the conditions summarized below applies:

- The thermocouple or RTD input must meet published* accuracy rates. Note that the factory calibration at reference is $\pm 1.2^{\circ}\text{F}$ plus ± 10 microvolts for thermocouples or ± 0.3 ohms for RTDs.
* Specifications 44-45-03-15
- You are using a 0–10 Vdc input. Recalibration is necessary because the resistor network used for this input has a tolerance of $\pm 1.0\%$.
- You have cause to believe that the recorder is out of calibration.
- You must perform regularly scheduled or periodic recalibration based on your own needs.
- You have performed specific servicing activities such as replacement of an input PCB.



ATTENTION

Replacing a main PCB does not normally require recalibration since a new main PCB is already factory calibrated, whereas an input PCB is not.

- You have changed the input type through configuration which results in the loss of the previous field calibration, but restores factory calibration. See *subsection 7.2 Restoring Factory Calibration* paragraph that follows.

What's in this section?

This section contains the following topics:

	Topic	See Page
7.1	Overview	177
7.2	Restoring Factory Calibration	178
7.3	Minimum and Maximum Range Values	180
7.4	Preliminary Information	181
7.5	Calibration Set Up and Wiring for PV Inputs	183
7.6	Calibration Procedure	192

7.2 Restoring Factory Calibration

How to restore it

The factory calibration constants for all the input actuation types that can be used with the DR4500A recorder are stored in its nonvolatile memory. Thus, you can quickly restore the “Factory Calibration” for a given input actuation type by simply configuring the actuation type through the IN1 TYPE (or IN2 TYPE) prompt to another type and then changing it back to the original type. See Table 7-1 for the procedure.



ATTENTION

This procedure applies only for factory-installed inputs. Any input that was field-installed must be field calibrated.

Procedure

Table 7-1 lists the procedure for restoring factory calibration.

Table 7-1 Restoring factory calibration

Step	Operation	Press	Action/Result
1	Enter Input Setup Group	SET UP	Until you see: <i>Upper Display: SET UP</i> <i>Lower Display: INPUT n n = 1 or 2</i>
2	Change input type	FUNC	Until you see: <i>Upper Display: Note the input type in the upper display. Make sure that the selection matches the type of sensor that is connected to the input in your application. Write it down, if necessary.</i> <i>Lower Display: INn TYPE n = 1 or 2</i>
		▲ or ▼	Until you see: <i>Upper Display: 0-10V</i> <i>Lower Display: INn TYPE</i> ATTENTION If you are already using a 0-10V input, change to a 0-5V input type.
		FUNC	Until the upper display rolls through the input types and returns to <i>Upper Display: 0-10V</i> <i>Lower Display: INn TYPE</i>

Step	Operation	Press	Action/Result
2 (cont)		▲ or ▼	Until you change the input selection in the upper display back to the proper selection. You will see: <i>Upper Display:</i> Original input selection that matches your type of sensor. <i>Lower Display:</i> INn TYPE
3	Return to normal operating mode	LOWR DISP	To return to Normal operating mode. The factory calibration will be restored. If the problem is not corrected, contact the Honeywell Technical Assistance Center. 1-800-423-9883 USA and Canada



CAUTION

A restored factory calibration overwrites any previous field calibration done for the input. Be sure to protect any field calibration from accidental overwrites by configuring the appropriate "LOCKOUT" selection after calibration. See the *Section 3 - Configuration* for specific instructions to set the lockout.

7.3 Minimum and Maximum Range Values

Select the range values

You should calibrate the recorder for the minimum (0%) and maximum (100%) range values of your particular sensor.

- If your recorder has two or more inputs, calibrate each input separately. Select the voltage or resistance equivalent for 0% and 100% range values from Table 7-2, use these values when calibrating your recorder.

Table 7-2 Voltage and resistance equivalents for 0% and 100% range values

Sensor Type	PV Input Range		Range Values*		
	°F	°C	0%	68°F/20°C	100%
Thermocouples					
B	105 to 3300	41 to 1816	0 mV	0.003 mV	13.763 mV
E	-454 to 1832	-270 to 1000	-9.835 mV	1.192 mV	76.358 mV
E (low)	-200 to 1100	-129 to 593	-6.471 mV		44.547 mV
J	0 to 1600	-18 to 871	-0.885 mV	1.019 mV	50.059 mV
J (low)	20 to 770	-7 to 410	-0.334 mV		22.397 mV
K	-320 to 2500	-196 to 1371	-5.822 mV	0.798 mV	54.845 mV
K (low)	-20 to 1000	-29 to 538	-1.114 mV		22.251 mV
NiNiMoly	32 to 2500	0 to 1371	-0.001 mV	1.458 mV	71.330 mV
NIC Nicrosil Nisil	0 to 2372	-17.8 to 1300	-0.461 mV	0.525 mV	47.502 mV
R	0 to 3100	-18 to 1704	-0.089 mV	0.111 mV	20.275 mV
S	0 to 3100	-18 to 1704	-0.092 mV	0.113 mV	17.993 mV
T	-300 to 700	-184 to 371	-5.341 mV	0.789 mV	19.095 mV
T (low)	-200 to 600	-129 to 316	-4.149 mV		15.769 mV
W5W26	0 to 4200	-18 to 2315	-0.234 mV	0.062 mV	37.066 mV
W5W26 (low)	0 to 2240	-18 to 1227	-0.234 mV		22.277 mV
RTD (IEC = 0.00385)					
100Ω	-300 to 900	-184 to 482	25.18Ω		274.96Ω
100Ω (RH)	-130 to 392	-90 to 200	64.30Ω		175.84Ω
500Ω	-300 to 900	-184 to 482	125.90Ω		1374.80Ω
Milliamps	4 to 20 mA		4 mA		20 mA
Millivolts	0 to 10 mV		0 mV		10 mV
	10 to 50 mV		10 mV		50 mV
Volts	0 to 5 Volts		0 Volts		5 Volts
	0 to 10 Volts**		0 Vols		10 Volts
Radiamatic (RH)	1400 to 3400	760 to 1871	0.99 mV		57.12 mV

*Range values for thermocouples are based on a cold junction temperature of 32°F (0°C). These values must be adjusted for the actual cold junction temperature when using the ambient temperature method for calibrating thermocouple inputs.

**Resistor network 30755232-002 must be installed in inputs #1 and #2 when using this range, see set up diagram for details.

7.4 Preliminary Information

Disconnect the field wiring

Depending on which input (#1 or #2) you are going to calibrate, tag and disconnect any field wiring connected to the input terminals on the input boards inside the recorder. Reference Figure 7-1 and follow the procedure in Table 7-3.

Table 7-3 Disconnect the field wiring

Step	Action
1	Remove the operating power from the recorder.
2	Open the door on the recorder.
3	Loosen the slotted cap screw on the right side of the chart plate, and open the chart plate.
4	Depending on the input (1 or 2) you are going to calibrate, remove the wired plug from the input connector (J2) on the applicable circuit board. See Figure 7-1 for the location of the circuit boards and input connectors.
5	Tag and disconnect the field wiring installed in the applicable input connector plug.

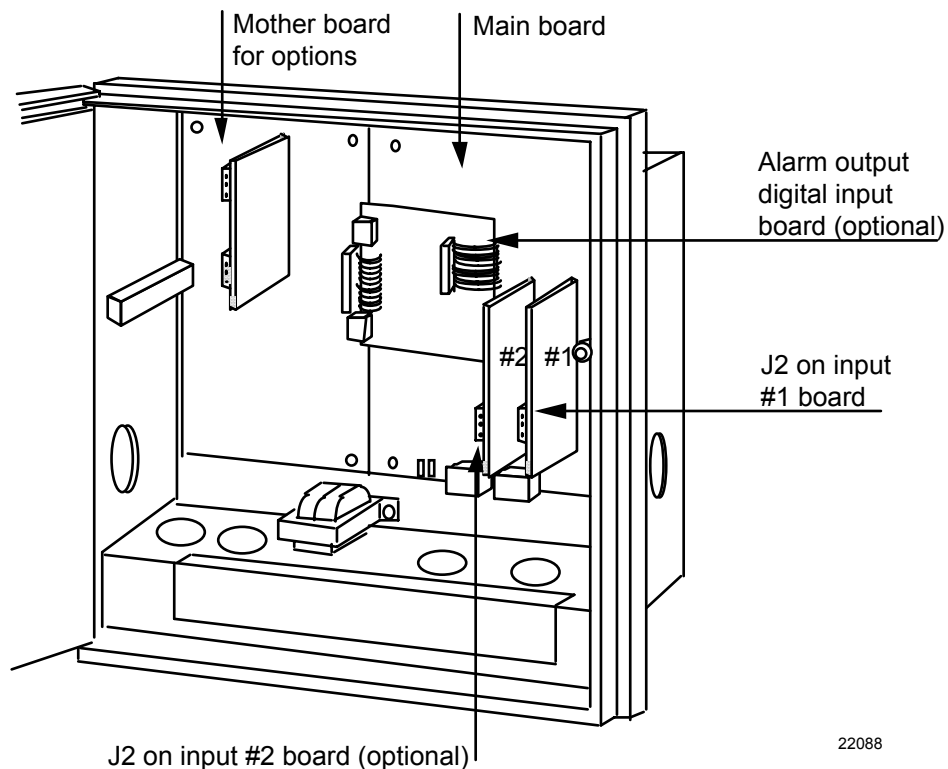


Figure 7-1 Location of the input connections on the input boards

Equipment needed

Table 7-4 lists the equipment required to calibrate the specific types of inputs listed in the table. You will need a medium size bladed screwdriver for general use and a small size bladed screwdriver for use with the screws on the connector plugs.

Table 7-4 Equipment needed

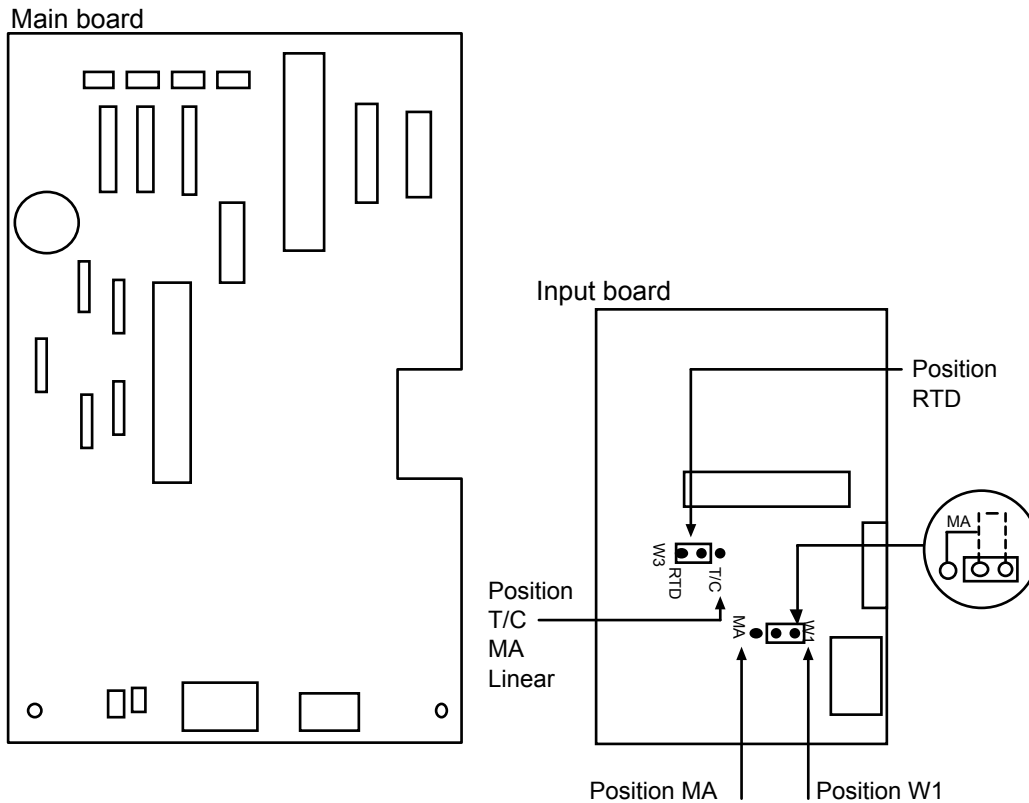
Type of Input	Equipment Needed
<i>Thermocouple Inputs (Ice Bath)</i>	<ul style="list-style-type: none"> • A calibrating device with $\pm 0.02\%$ accuracy for use as a signal source such as a millivolt source. • Thermocouple extension wire that corresponds with the type of thermocouple that will be used with the recorder input. • Two insulated copper leads for connecting the thermocouple extension wire from the ice baths to the precision calibrator. • Two containers of crushed ice.
<i>Thermocouple Inputs (Ambient Temperature)</i>	<ul style="list-style-type: none"> • A calibrating device with $\pm 0.02\%$ accuracy for use as a signal source such as a millivolt source. • Two insulated copper leads for connecting the calibrator to the recorder.
<i>Thermocouple Inputs (Compensated Calibrator)</i>	<ul style="list-style-type: none"> • A calibrating device with temperature compensation and $\pm 0.02\%$ accuracy for use as a signal source. • Thermocouple extension wire that corresponds with the type of thermocouple that will be used with the recorder input.
<i>RTD (Resistance Thermometer Device)</i>	<ul style="list-style-type: none"> • A resistance decade box, with $\pm 0.02\%$ accuracy, capable of providing stepped resistance values over a minimum range of 0 to 1400 ohms with a resolution of 0.01 ohm. • Three insulated copper leads for connecting the decade box to the controller.
<i>Radiomatic, Milliampere, Millivolt, and Volts Inputs</i>	<ul style="list-style-type: none"> • A calibrating device with $\pm 0.02\%$ accuracy for use as a signal source. • Two insulated copper leads for connecting the calibrator to the controller.

7.5 Calibration Set Up and Wiring for PV Inputs

Jumper positions

Before starting the calibration activity, check that the jumper plugs on the applicable input circuit board are installed in the proper jumper position (in W1/MA and W3) for the particular sensor being used (refer to the wiring connection drawings in this section for each individual setting).

Refer to Figure 7-2 for the location of jumper positions W1/MA and W3 on these circuit boards, and the status of these jumpers for each type of input sensor.



Status of jumper plugs

1. Install W1/MA plug in position W1 for thermocouple, RTD, Radiamatic, mV, 0-5 Vdc, 0-10 Vdc inputs.
2. Install W1/MA plug in position MA for 4-20 mA inputs.
3. Install plug in W3 according to your input type.

21443

Figure 7-2 Location of jumper positions W1/MA and W3 on the input boards

Thermocouple input calibration methods

You can calibrate for a thermocouple input using one of three methods:

- using an ice bath,
- using a compensated calibrator, or
- by measuring the ambient temperature at the input terminals and subtracting the voltage contribution of the input terminal junction.

General set up procedure

Table 7-5 lists the general set up procedure for all methods of calibration. Do this procedure and then refer to the set up procedure and diagram for your specific input.

Table 7-5 General set up procedure

Step	Action
1	Set up and connect the calibrator to the input plug for the applicable input circuit board in your recorder according to the particular input sensor being used. Refer to the following figures for corresponding set-up diagrams: <ul style="list-style-type: none">• Figure 7-3 Thermocouple inputs using an ice bath• Figure 7-4 Thermocouple inputs using a compensated calibrator• Figure 7-5 Thermocouple inputs using the ambient temperature method• Figure 7-6 RTD (Resistance Thermometer Device) inputs• Figure 7-7 Radiamatic, mV and Volts (except 0–10 Volts) inputs• Figure 7-8 0-10 Volts input• Figure 7-9 4–20 mA inputs
2	Route leads (for example: copper leads or thermocouple extension wires) through a conduit hole in the recorder case so that you will be able to close the chart plate.
3	Close the chart plate after you have completed the applicable calibration set up.

Thermocouple inputs using an ice bath

Refer to Figure 7-3 and wire the recorder according to the procedure given in Table 7-6.

Table 7-6 Set up wiring procedure for Thermocouple inputs using an ice bath

Step	Action
1	Connect the copper leads to the calibration source (see Figure 7-3).
2	Connect a length of thermocouple extension wire to the end of each copper lead and insert the junction points into the ice bath.
3	Connect the other end of the thermocouple extension wires to the clamp type terminals in the plug for the applicable input connector (J2).
4	Reinstall the plug into the input connector (J2) on the applicable circuit board for Input 1 or Input 2.

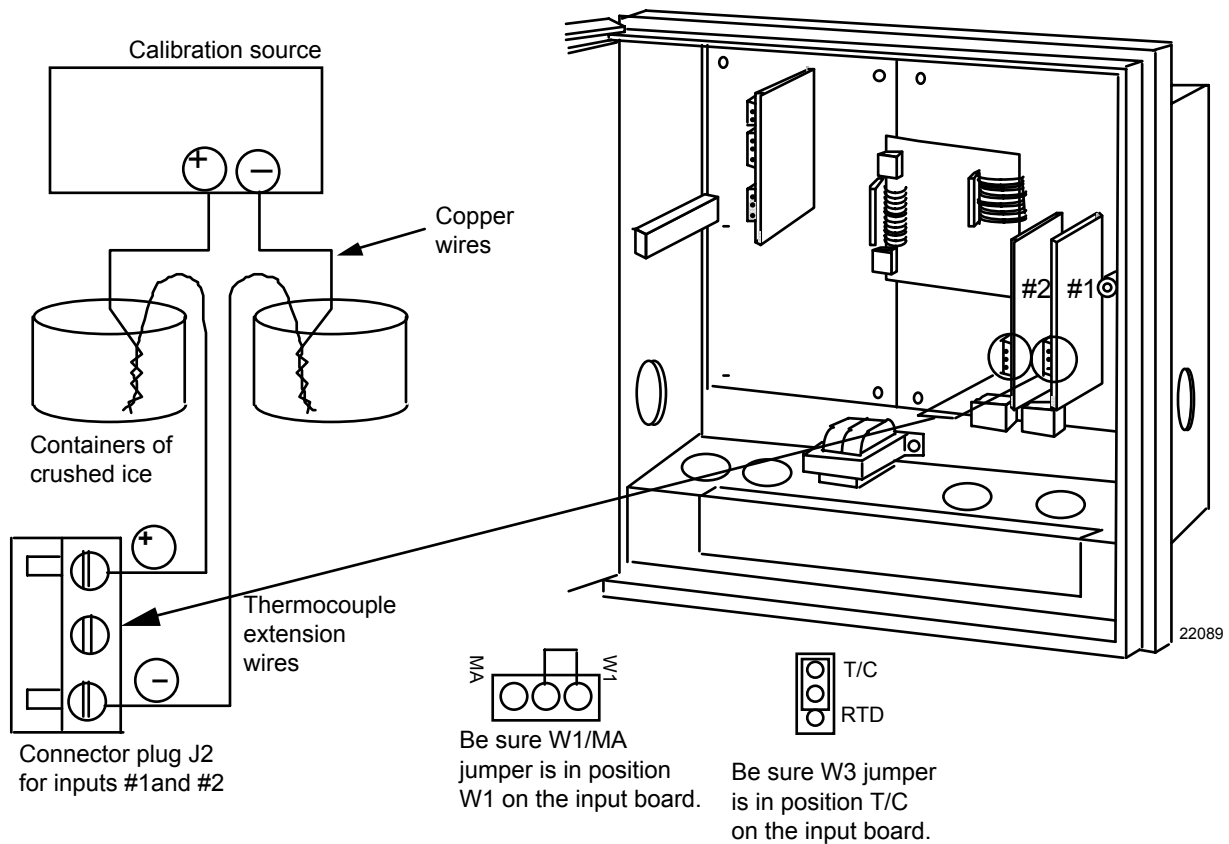


Figure 7-3 Calibration set up diagram for Thermocouple inputs using an ice bath

Thermocouple inputs using a compensated calibrator method

Refer to Figure 7-4 and wire the recorder according to the procedure given in Table 7-7.

Table 7-7 Set up wiring procedure for Thermocouple inputs using a compensated calibrator method

Step	Action
1	Connect the thermocouple extension wire to the Precision Compensated Calibrator (see Figure 7-4).
2	Connect the other end of the thermocouple extension wires to the clamp type terminals in the plug for the applicable input connector (J2).
3	Reinstall the plug into the input connector (J2) on the applicable circuit board for Input 1 or Input 2.

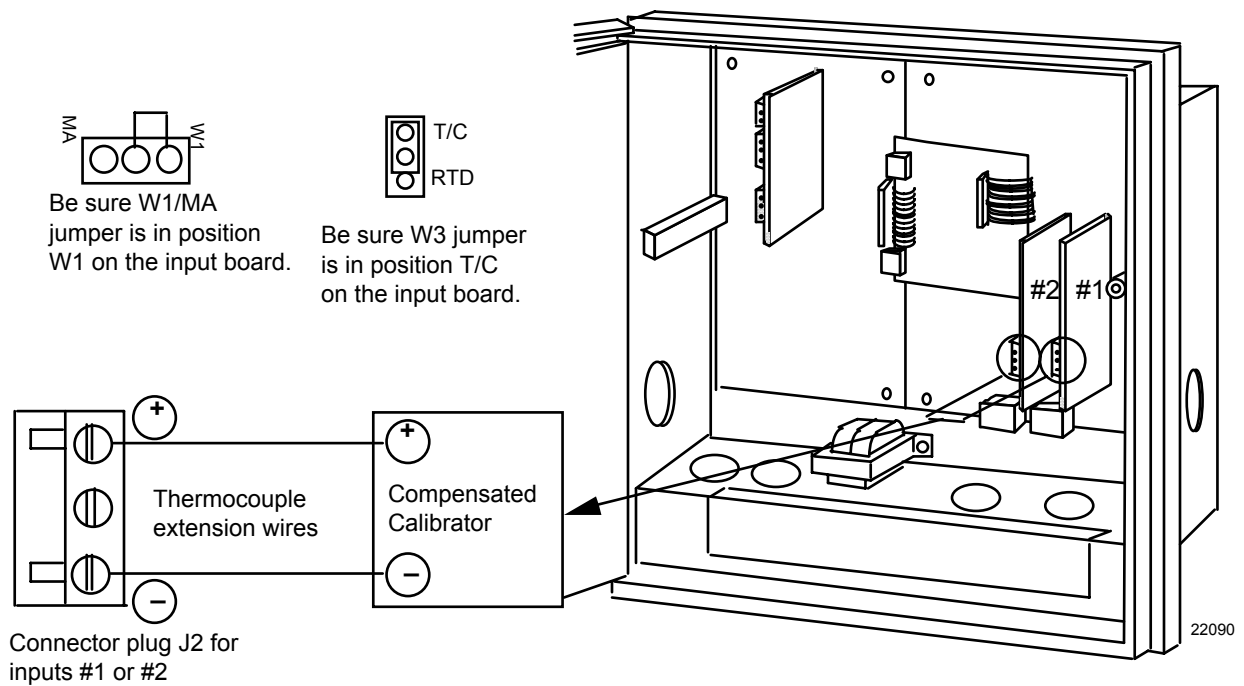


Figure 7-4 Calibration set up diagram for Thermocouple inputs using a compensated calibrator method

Thermocouple inputs using the ambient temperature method

Refer to Figure 7-5 and wire the recorder according to the procedure given in Table 7-8.

Table 7-8 Set up wiring procedure for Thermocouple inputs using the ambient temperature method

Step	Action
1	Connect the copper wire to the Precision Millivolt Source (see Figure 7-5).
2	Connect the other end of the copper wire to the clamp type terminals in the plug for the applicable input connector (J2).
3	Reinstall the plug into the input connector (J2) on the applicable circuit board for input 1 or input 2.

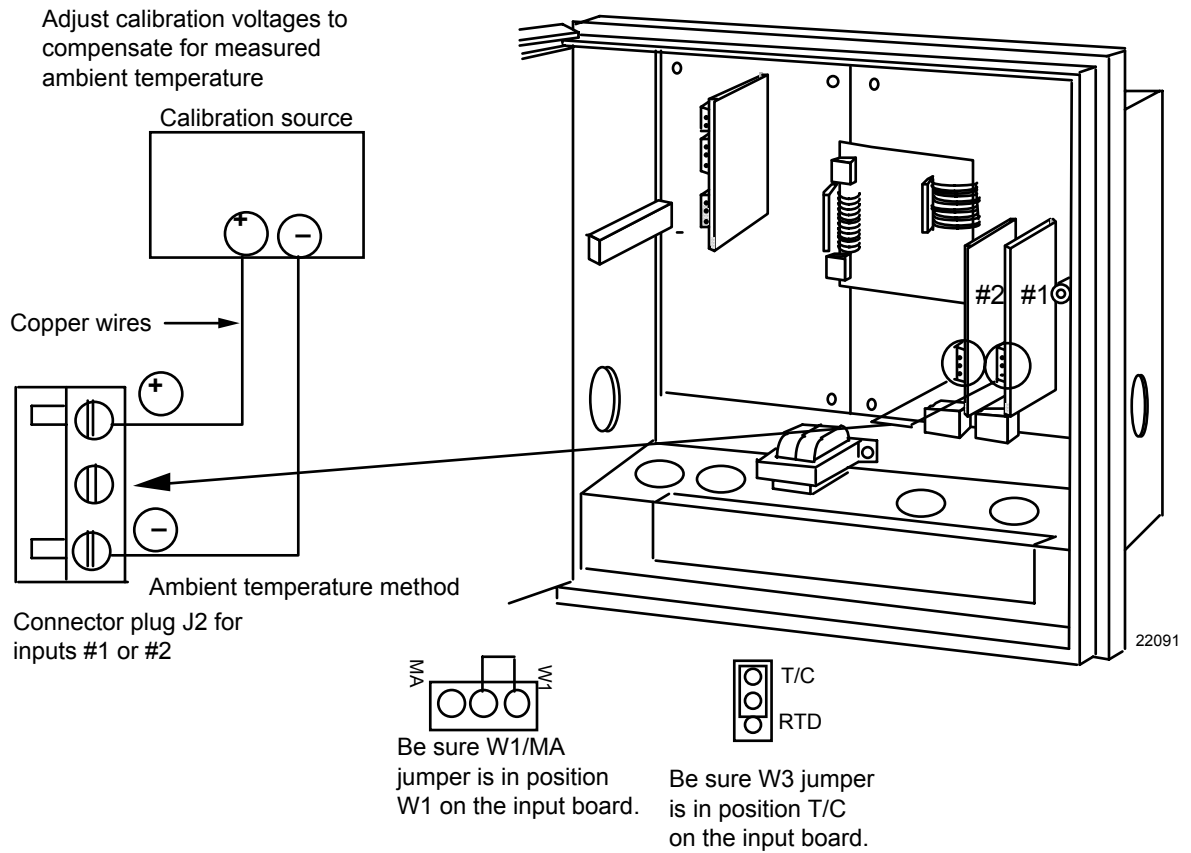


Figure 7-5 Calibration set up diagram for Thermocouple inputs using the ambient temperature method

RTD (Resistance Thermometer Device) inputs

Refer to Figure 7-6 and wire the recorder according to the procedure given in Table 7-9.

Table 7-9 Set up wiring procedure for RTD inputs

Step	Action
1	Connect the copper wire to the calibration source (see Figure 7-6).
2	Connect the other end of the copper wire to the clamp type terminals in the plug for the applicable input connector (J2).
3	Reinstall the plug into the input connector (J2) on the applicable circuit board for input 1 or input 2.

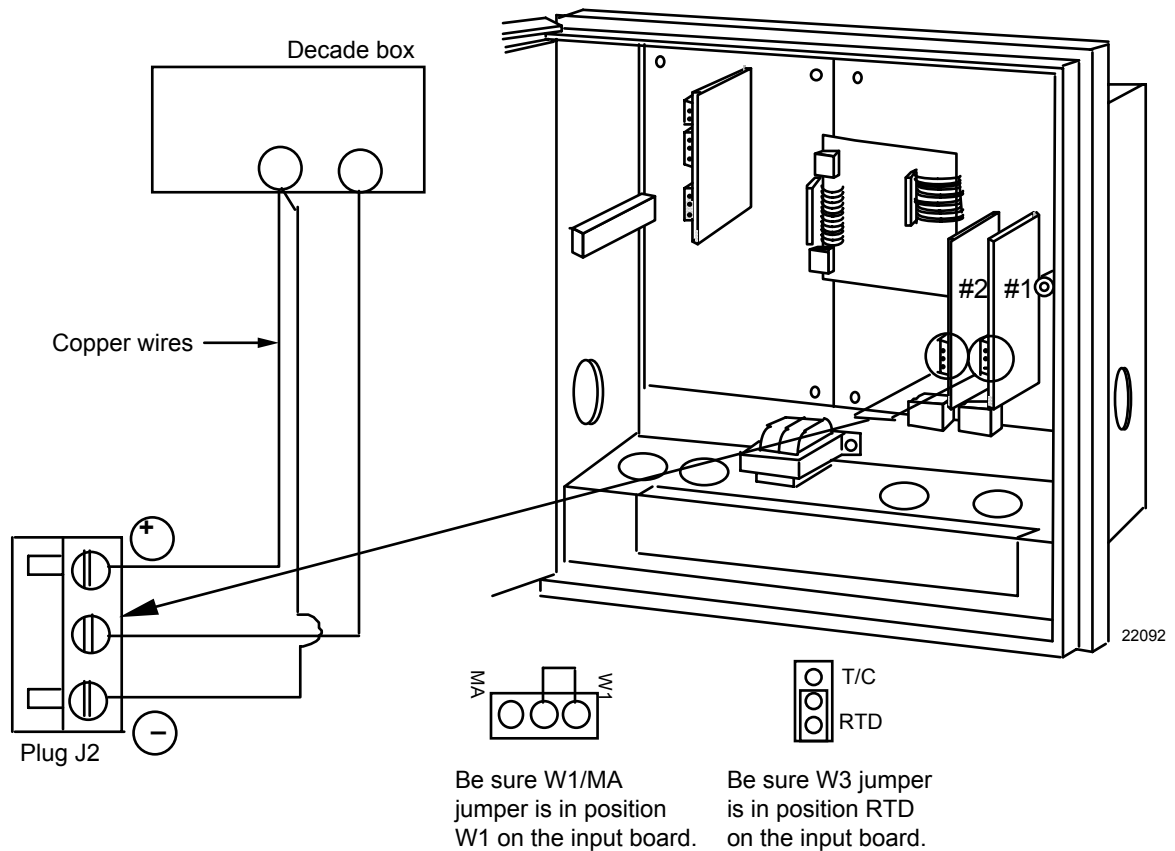


Figure 7-6 Calibration set up diagram for RTD inputs

Radiamatic, millivolts, and volts inputs (except 0–10 Volts)

Refer to Figure 7-7 and wire the recorder according to the procedure given in Table 7-10.

Table 7-10 Set up wiring procedure for Radiamatic, Millivolts, and Volts inputs (except 0-10 Volts)

Step	Action
1	Connect the copper wire to the calibration source (see Figure 7-7).
2	Connect the other end of the copper wire to the clamp type terminals in the plug for the applicable input connector (J2).
3	Reinstall the plug into the input connector (J2) on the applicable circuit board for input 1 or input 2.

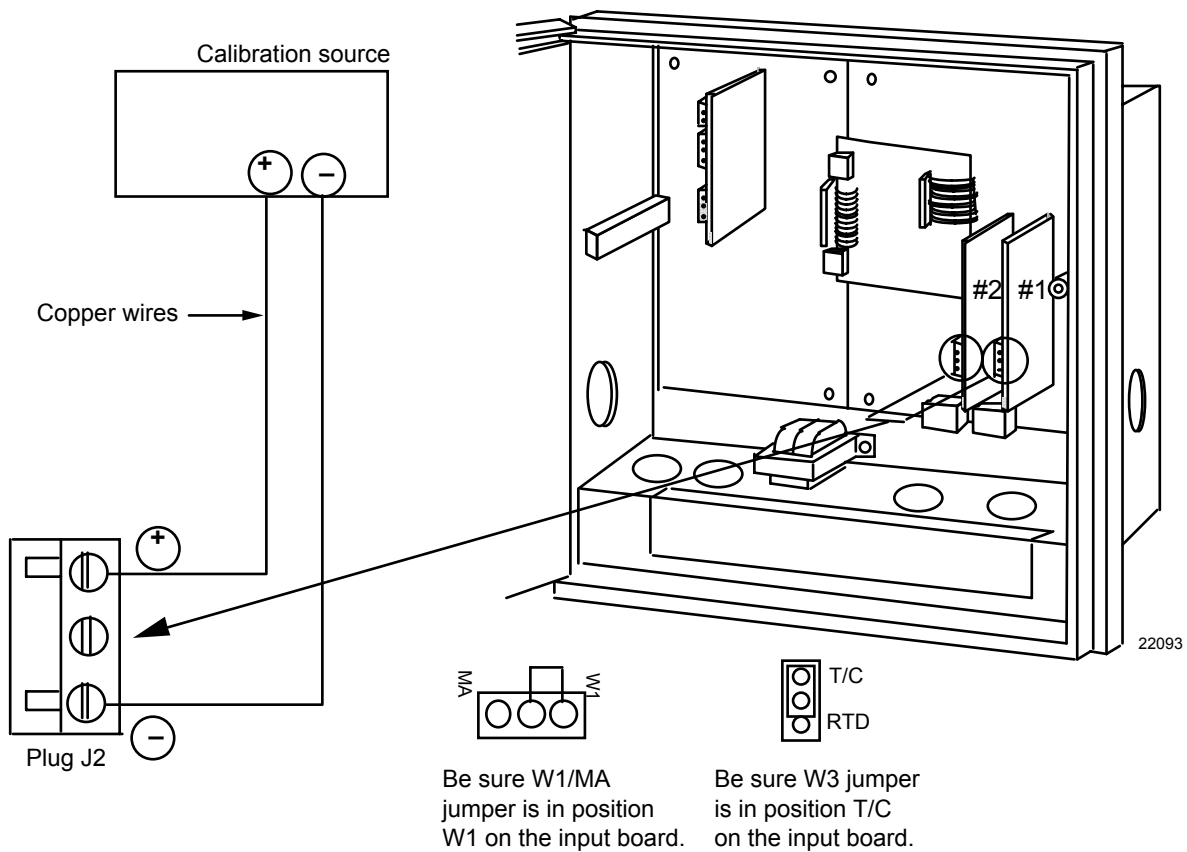


Figure 7-7 Calibration set up diagram for Radiamatic, Millivolts, and Volts inputs (except 0-10 Volts)

0–10 Volt inputs

Refer to Figure 7-8 and wire the recorder according to the procedure given in Table 7-11.

Table 7-11 Set up wiring procedure for 0–10 Volt inputs

Step	Action
1	Connect the copper wire to the calibration source (see Figure 7-8).
2	Connect the other end of the copper wire to the clamp type terminals in the plug for the applicable input connector (J2).
3	Reinstall the plug into the input connector (J2) on the applicable circuit board for input 1 or input 2.

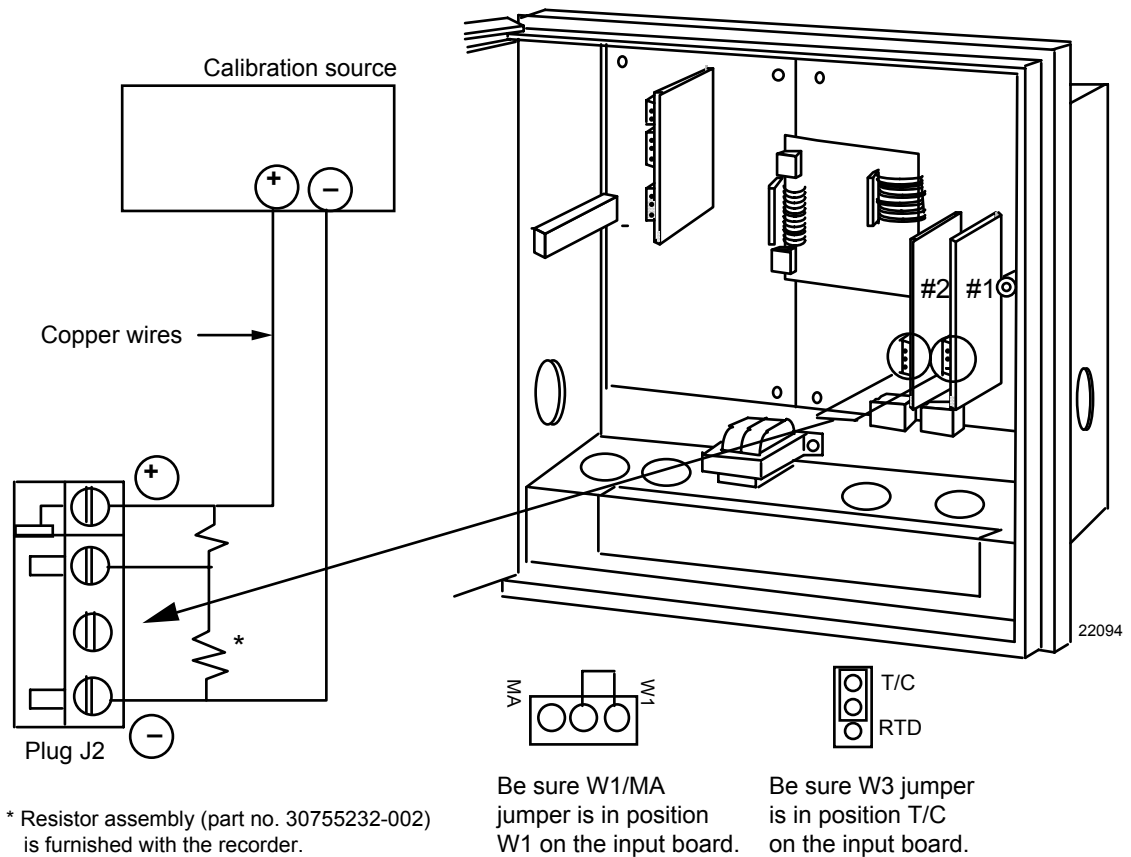


Figure 7-8 Calibration set up diagram for 0–10 Volt inputs

4–20 mA inputs

Refer to Figure 7-9 and wire the recorder according to the procedure given in Table 7-12.

Table 7-12 Set up wiring procedure for 4–20 mA inputs

Step	Action
1	Connect the copper wire to the calibration source (see Figure 7-9).
2	Connect the other end of the copper wire to the clamp type terminals in the plug for the applicable input connector (J2).
3	Reinstall the plug into the input connector (J2) on the applicable circuit board for input 1 or input 2.

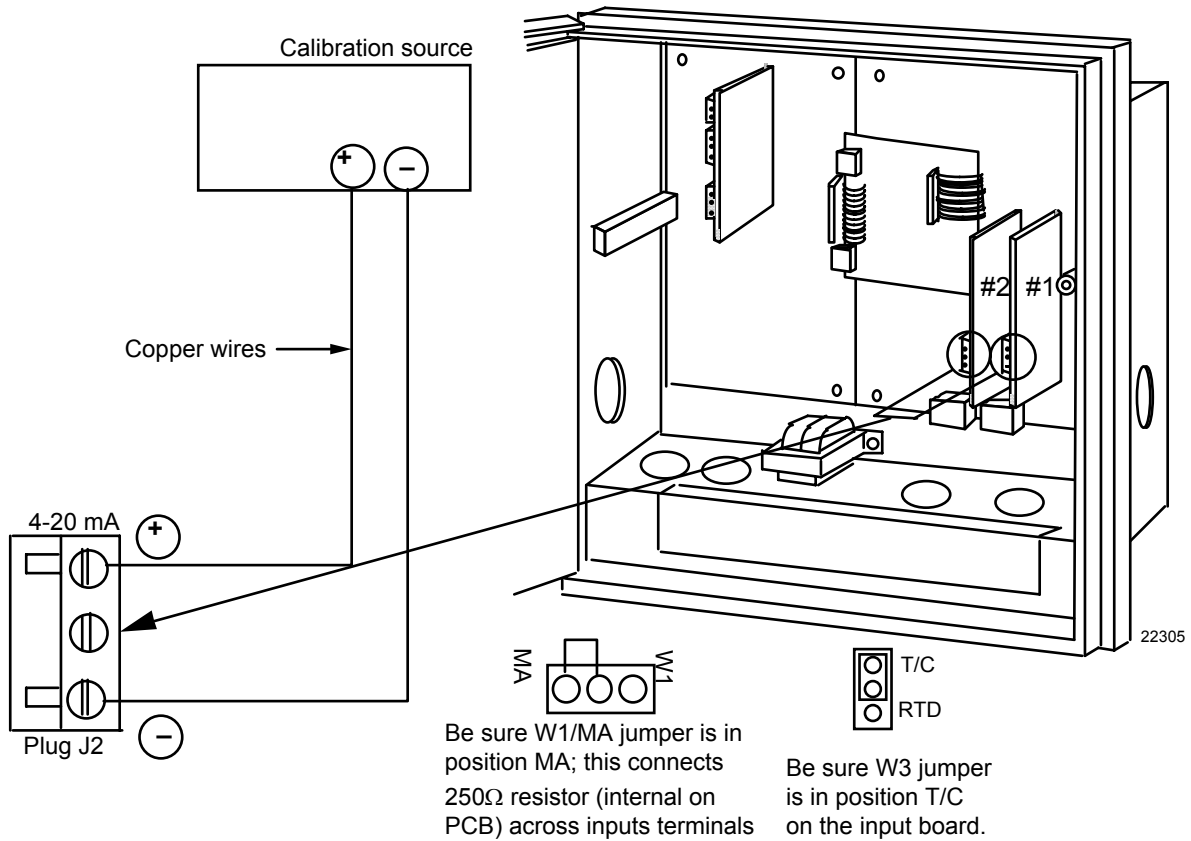


Figure 7-9 Calibration set up diagram for 4–20 mA inputs

7.6 Calibration Procedure

Introduction

Apply power and allow the recorder to warm up for one hour before you calibrate.

- Please read “*Set Up Wiring*” before beginning the procedure.
- Make sure “LOCKOUT” is set to “NONE” (see *Section 3 – Configuration*).
- The calibration procedure for inputs #1 and #2 are identical. The displays indicate the input number.



CAUTION

For *milliampere inputs*, be sure the current source is at zero before switching on the calibrator. Do not switch the calibrator on/off while it is connected to the recorder's input.



ATTENTION

For *linear inputs*, avoid step changes in input signal. Vary calibration source signal smoothly from initial value to final 100% value.

Calibration procedure sequence

The calibration procedure sequence for all inputs is listed in Table 7-13.

Table 7-13 Calibration procedure sequence

Step	Operation	Press	Action/Result
1	Enter Calibration Mode	SET UP	Until you see: <i>Upper Display: CALIB</i> <i>Lower Display: INPUT n</i> n = 1 or 2
		FUNC	You will see: <i>Upper Display: DISABL</i> <i>Lower Display: CAL INn</i> n = 1 or 2
		▲	The calibration sequence is enabled and you will see: <i>Upper Display: BEGIN</i> <i>Lower Display: CAL INn</i>
2	Calibrate 0%	FUNC	You will see: <i>Upper Display: APPLY</i> <i>Lower Display: INn ZERO</i> n = 1 or 2 <ul style="list-style-type: none"> • Adjust your calibration device to an output signal equal to the 0% range value for your particular input sensor, see Table 7-2 for Voltage or Resistance equivalents. • Wait 30 seconds, then go to step 3.

Step	Operation	Press	Action/Result									
2 (cont)	Using Ambient Temperature Method		<p>ATTENTION If you are using the Ambient Temperature method to calibrate a thermocouple input, be sure to measure the temperature at the input terminals and subtract the equivalent millivolt value (for your particular thermocouple) from the 0% value just prior to doing calibration.</p> <p>For example, for a Type J Thermocouple and input temperature of 68°F:</p> <table style="margin-left: 40px;"> <tr> <td>From</td> <td>-0.885 mV</td> <td>(Type J @ 0°F)</td> </tr> <tr> <td>Subtract</td> <td><u>-1.019 mV</u></td> <td>(Type J @ 68°F)</td> </tr> <tr> <td>To yield</td> <td>-1.904 mV</td> <td>(calibrator output for INn ZERO)</td> </tr> </table>	From	-0.885 mV	(Type J @ 0°F)	Subtract	<u>-1.019 mV</u>	(Type J @ 68°F)	To yield	-1.904 mV	(calibrator output for INn ZERO)
From	-0.885 mV	(Type J @ 0°F)										
Subtract	<u>-1.019 mV</u>	(Type J @ 68°F)										
To yield	-1.904 mV	(calibrator output for INn ZERO)										
3	Calibrate 100%	FUNC	<p>You will see:</p> <p style="margin-left: 40px;"><i>Upper Display:</i> APPLY</p> <p style="margin-left: 40px;"><i>Lower Display:</i> INn SPAN n = 1 or 2</p> <p>Adjust your calibration device to an output signal equal to the 100% range value for your particular input sensor, see Table 7-2 for voltage or resistance equivalents, wait 30 seconds, and</p> <table border="1" style="margin-left: 40px;"> <thead> <tr> <th data-bbox="846 972 1216 1020">If ...</th> <th data-bbox="1216 972 1382 1020">Then ...</th> </tr> </thead> <tbody> <tr> <td data-bbox="846 1020 1216 1094">you are calibrating a thermocouple input</td> <td data-bbox="1216 1020 1382 1094">Go to step 4</td> </tr> <tr> <td data-bbox="846 1094 1216 1167">you are calibrating other than a thermocouple input</td> <td data-bbox="1216 1094 1382 1167">Go to step 5</td> </tr> </tbody> </table>	If ...	Then ...	you are calibrating a thermocouple input	Go to step 4	you are calibrating other than a thermocouple input	Go to step 5			
If ...	Then ...											
you are calibrating a thermocouple input	Go to step 4											
you are calibrating other than a thermocouple input	Go to step 5											
	Using Ambient Temperature Method		<p>ATTENTION If you are using the Ambient Temperature method to calibrate a thermocouple input, be sure to measure the temperature at the input terminals and subtract the equivalent millivolt value (for your particular thermocouple) from the 100% value.</p> <p>For example, for a Type J Thermocouple and input temperature of 68°F:</p> <table style="margin-left: 40px;"> <tr> <td>From</td> <td>50.059 mV</td> <td>(Type J @ 1600°F)</td> </tr> <tr> <td>Subtract</td> <td><u>-1.019 mV</u></td> <td>(Type J @ 68°F)</td> </tr> <tr> <td>To yield</td> <td>49.040 mV</td> <td>(calibrator output for INn SPAN)</td> </tr> </table>	From	50.059 mV	(Type J @ 1600°F)	Subtract	<u>-1.019 mV</u>	(Type J @ 68°F)	To yield	49.040 mV	(calibrator output for INn SPAN)
From	50.059 mV	(Type J @ 1600°F)										
Subtract	<u>-1.019 mV</u>	(Type J @ 68°F)										
To yield	49.040 mV	(calibrator output for INn SPAN)										

Step	Operation	Press	Action/Result
4	<p>Check the Cold Junction Temperature</p> <p>WARNING The accuracy of the recorder is directly affected by the accuracy of this value. Change this value only if the zero and span calibration procedures did not bring the recorder within the specified accuracy requirements.</p>	<p>FUNC</p>	<p>The calculations for zero and span are now stored and you will see:</p> <p><i>Upper Display:</i> The cold junction temperature at the rear terminals</p> <p><i>Lower Display:</i> C-J TEMP</p> <ul style="list-style-type: none"> • The value in the upper display is in the tenths of a degree. It is the current reading of the temperature as measured at the thermocouple terminals (that is, at J2) and recognized by the recorder. • When using the Ice Bath method, this value should be the terminal ambient temperature. <ul style="list-style-type: none"> – You can change this value, if it is in error, using the ▲ or ▼ key.
5	<p>Exit the Calibration Mode</p>	<p>LOWR DISP</p> <p>or</p> <p>SET UP</p>	<p>The recorder stores the calibration constants and exit calibration mode.</p>

8. Output Calibration

8.1 Overview



SHOCK HAZARD—WARNING!

Disregard of these instructions may cause injury or death.

OUTPUT CALIBRATION MAY REQUIRE ACCESS TO HAZARDOUS LIVE CIRCUITS, AND SHOULD ONLY BE PERFORMED BY QUALIFIED SERVICE PERSONNEL. MORE THAN ONE SWITCH MAY BE REQUIRED TO DE-ENERGIZE UNIT BEFORE CALIBRATION.

Introduction

This section describes the field calibration procedures for the following types of outputs:

- Current Output
- Position Proportional Output
- Auxiliary Output



ATTENTION

Calibration for Control Outputs #1 and #2 is identical except for the particular printed circuit board involved.

What's in this section

This section contains the following topics:

	Topic	See Page
8.1	Overview	195
8.2	Current Proportional Output/Aux Out 2 and 3 Calibration	196
	• Introduction	196
	• Equipment needed	196
	• Calibrator connections	196
	• Calibration Procedure	197
8.3	Position Proportional Output Calibration	198
	• Position proportional control	198
	• Equipment needed	198
	• Connections	198
	• Auto mode vs manual mode	198
	• Displayed values	198
	• Calibration Procedure	198
8.4	Auxiliary Output Calibration	201
	• Introduction	201
	• Equipment needed	201
	• Calibrator connections	201
	• Calibration Procedure	202

8.2 Current Proportional Output/Aux Out 2 and 3 Calibration

Introduction

Calibrate the recorder so that the output provides the proper amount of current over the desired range.

- The recorder can provide an output current range of from 2 to 21 milliamperes and can be calibrated at 4 mA for 0 % of output and 20 mA for 100 % of output or any other values between 2 and 21 mA.

Equipment needed

You will need a standard shop type milliammeter, with whatever accuracy is required, capable of measuring 0 to 20 milliamps.

Calibrator connections

Refer to Figure 8-1 and wire the recorder according to the procedure given in Table 8-1.

Table 8-1 Set up wiring procedure current proportional output/Aux Out 2 and 3

Step	Action
1	With the power off, door open, and the chart plate swung out; tag and disconnect field wiring from the plug in connector J1 on the appropriate control output PCB (see Figure 8-1).
2	Observing polarity, connect a milliammeter's leads to the plug for connector J1.
3	Close the chart plate: apply power and allow the recorder to warm up 15 minutes before you calibrate.

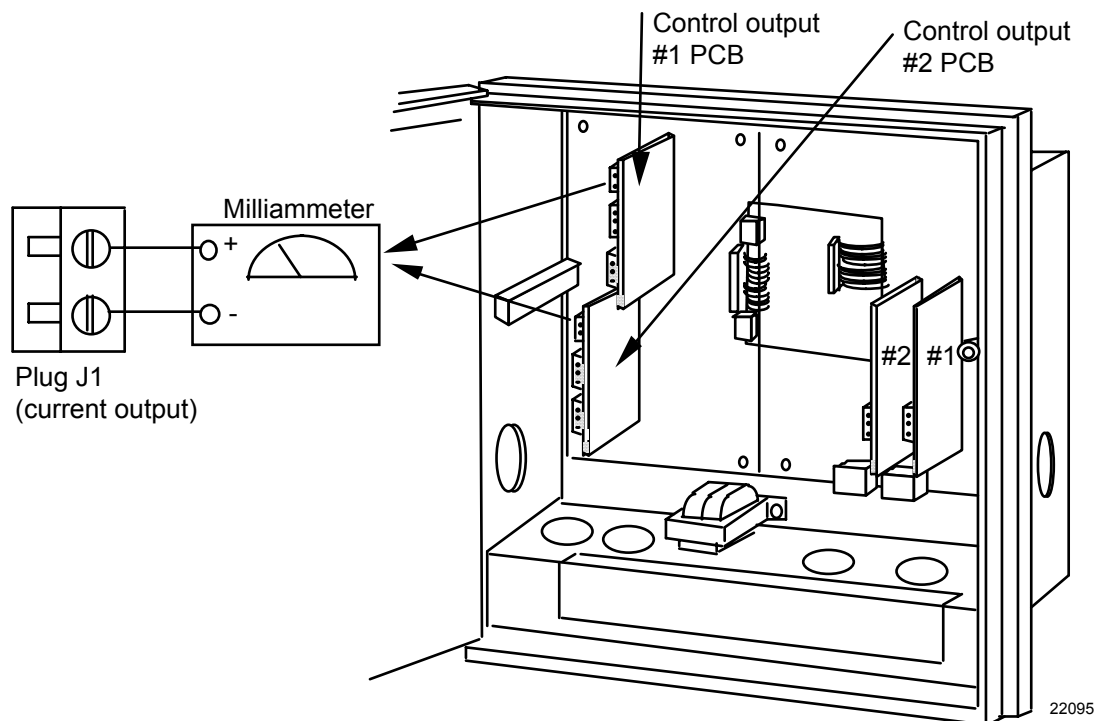


Figure 8-1 Test equipment connections for calibrating current proportional output

Procedure

The procedure for calibrating the Current Proportional Output is listed in Table 8-2. Make sure "LOCKOUT" in the Set Up group is set to "NONE." See *Section 3 – Configuration*. Also, "CONTROL 1/2" must be enabled and "OUT ALG" must be set to "CURRNT" in the Control Set Up group.



ATTENTION

Follow this procedure when calibrating Auxiliary Output #2 or #3. Make sure "LOCKOUT" in the Set Up group is set to "NONE" and "AUX OUT" must **NOT** be disabled in the Auxiliary Output group.

Table 8-2 Current proportional output/Aux Out 2 and 3 calibration procedure

Step	Operation	Press	Action/Result
1	Enter Calibration Mode	SET UP	Until you see: <i>Upper Display: CALIB</i> <i>Lower Display: CURRENT</i>
2	Calibrate 0 %	FUNC	You will see: <i>Upper Display: (a value)</i> (approximately 380) <i>Lower Display: ZERO VAL</i>
		▲ or ▼	Until the desired 0 % output is read on the milliammeter. Use the values shown below depending on the action of your recorder. 4 mA For 4 to 20 mA Direct Action 20 mA For 4 to 20 mA Reverse Action
3	Calibrate 100 %	FUNC	Stores the 0 % value and you will see: <i>Upper Display: (a value)</i> (approximately 1890) <i>Lower Display: SPAN VAL</i>
		▲ or ▼	Until the desired 100 % output is read on the milliammeter. Use the values shown below depending on the action of your recorder. 20 mA For 4 to 20 mA Direct Action 4 mA For 4 to 20 mA Reverse Action
4	Exit the Calibration Mode	FUNC	The recorder stores the span value.
		LOWR DISP or SET UP	To exit the calibration mode.

8.3 Position Proportional Output Calibration

Position proportional control

When the DR4500A Recorder has a position proportional control output, calibrate the recorder so that the increase and decrease relays operate properly with respect to the position of the external feedback slidewire.

Equipment needed

None

Connections

Leave all field wiring connected to the plugs in connectors J2 and J5 on the appropriate control output printed circuit board.

Apply power and allow the recorder to warm up 15 minutes before you calibrate.

Auto mode vs manual mode

There are two ways in which to calibrate Position Proportional control:
AUTO mode or MANUAL mode.

Rules for auto mode vs manual mode

The auto-mode selection must be done at least once before the manual mode will operate properly. Failure to use the auto-mode procedure will prevent the recorder from going into automatic control mode.

Displayed values

During the auto-mode calibration procedure, the values being displayed are used only to indicate if the motor is still traveling.

To view the actual calibration value, use the manual mode after the auto-mode is completed. These values can be changed for purposes of tweaking the calibration.

Procedure

The procedure for calibrating the position proportional output control output is listed in Table 8-3.

- Make sure “LOCKOUT” in the Set Up group is set to “NONE.” See *Section 3 – Configuration*. Also, “CONTROL 1/2” must be enabled in the Control Set Up group.
- Make sure “CONT ALG” = “PID A” and “OUT ALG” = “POSITN” in the Control Set Up group.

Table 8-3 Position proportional output calibration procedure

Step	Operation	Press	Action/Result
1	Enter Calibration Mode	SET UP	Until you see: <i>Upper Display: CALIB</i> <i>Lower Display: POS PROP</i>
2	Set Motor Traverse Time NOTE: This is the time it takes the motor to travel from 0 to 100 %.	FUNC	Until you see: <i>Upper Display: (a value)</i> <i>Lower Display: MTR TIME</i>
		▲ or ▼	Until the proper motor stroke time is reached (see the motor specs or measure the time). • Range of setting = 5 to 255 Seconds
3	Select Automatic or Manual Calibration	FUNC	Until you see: <i>Upper Display: DISABL</i> <i>Lower Display: POS PROP</i> • You can calibrate the control output manually or let the recorder calibrate the control output automatically. • In the "Automatic Calibration Mode" (DO AUTO), the control relays automatically move the motor in the proper direction. • If desired, however, the motor may be manually positioned to 0 % and 100 % positions. Disconnect the relay wires. "DO MAN". • In the "Manual Calibration Mode" (DO MAN) the motor does not move. Instead, the existing 0 % and 100 % values may be changed with the ▲ or ▼ keys.
		▲ or ▼	Select automatic or manual calibration. <i>Upper Display: DO AUTO or DO MAN</i> <i>Lower Display: POS PROP</i> • If you select DO AUTO, go to step 4. • If you select DO MAN, go to step 6. ATTENTION When calibration is terminated, this selection reverts to DISABL.
4	DO AUTO Set 0 % value	FUNC	The decrement relay is turned on to move the motor to 0 % position. <i>Upper Display: (counts of feedback slidewire)</i> <i>(0 to 2047)</i> <i>Lower Display: ZERO VAL</i> • When the motor stops, the display should stop counting; go to the next step.

Step	Operation	Press	Action/Result
5	Set 100 % value	FUNC	<p>The increment relay is turned on to move the motor to 100 % position.</p> <p><i>Upper Display: (counts of feedback slidewire) (0 to 2047)</i></p> <p><i>Lower Display: SPAN VAL</i></p> <ul style="list-style-type: none"> When the motor stops, the display should stop counting, then go on to step 8.
6	DO MAN Set 0 % value	FUNC	<p>You will see:</p> <p><i>Upper Display: (existing zero calibration value in counts) (approximately 100)</i></p> <p><i>Lower Display: ZERO VAL</i></p>
		▲ or ▼	<p>Until the desired zero value is reached in the upper display.</p> <p><i>Upper Display: (desired zero value)</i></p> <p><i>Lower Display: ZERO VAL</i></p>
7	Set 100 % value	FUNC	<p>The recorder stores the 0 % value and you will see:</p> <p><i>Upper Display: (existing span calibration value in counts) (approximately 1500)</i></p> <p><i>Lower Display: SPAN VAL</i></p>
		▲ or ▼	<p>Until the desired span value is reached in the upper display.</p> <p><i>Upper Display: (desired span value)</i></p> <p><i>Lower Display: SPAN VAL</i></p> <p>For manual calibration, the motor does not move from its position prior to the start of position proportional calibration.</p>
8	Exit the Calibration Mode	FUNC	The recorder stores the 100 % value.
		LOWR DISP or SET UP	To exit the calibration mode.

8.4 Auxiliary Output Calibration

Introduction

Calibrate the recorder so that the auxiliary output provides the proper amount of current over the desired range.

- The recorder can provide an auxiliary output current range of from 2 to 21 milliamperes and can be calibrated at 4 mA for 0 % of output and 20 mA for 100 % of output or any other values between 2 and 21 mA.

Equipment needed

You will need a standard shop type milliammeter, with whatever accuracy is required, capable of measuring 0 to 20 milliamps.

Calibrator connections

Refer to Figure 8-2 and wire the recorder according to the procedure given in Table 8-4.

Table 8-4 Set up wiring procedure for auxiliary output

Step	Action
1	With the power off, door open, and the chart plate swung out, tag and disconnect field wiring from the plug in connector J2 on the auxiliary output PCB (see Figure 8-2).
2	Observing polarity, connect a milliammeter's leads to the plug for connector J2.
3	Close the chart plate; apply power and allow the recorder to warm up 15 minutes before you calibrate.

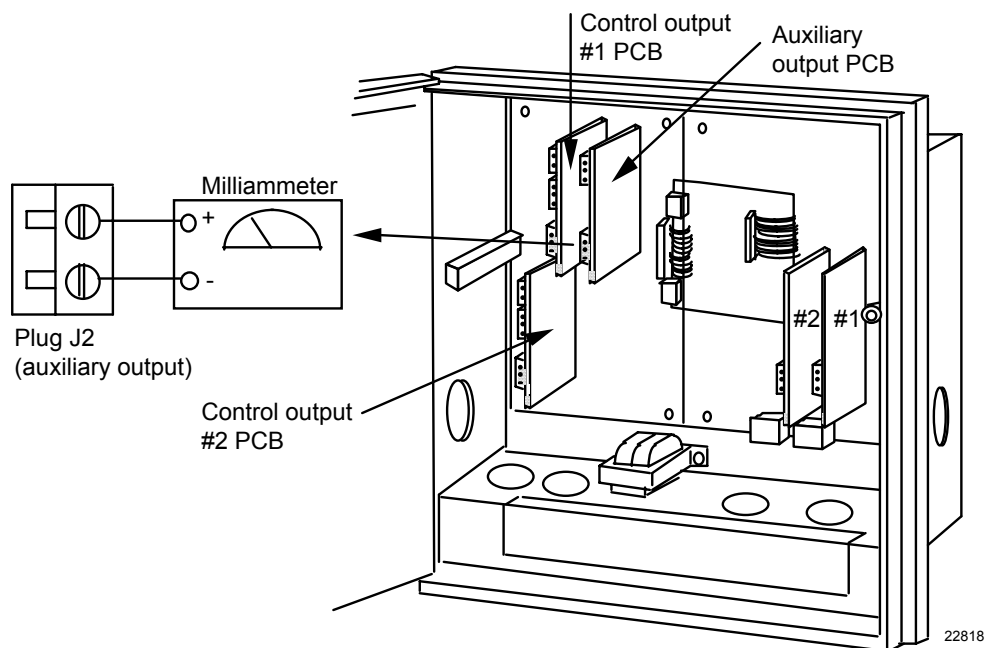


Figure 8-2 Test equipment connections for calibrating auxiliary output

Procedure

The procedure for calibrating the Auxiliary Output is listed in Table 8-5. Make sure “LOCKOUT” in the Set Up group is set to “NONE.” See *Section 3 – Configuration*. Also, “AUX OUT” must **NOT** be disabled.

Table 8-5 Auxiliary output calibration procedure

Step	Operation	Press	Action/Result
1	Enter Calibration Mode	SET UP	Until you see: <i>Upper Display: CALIB</i> <i>Lower Display: AUX OUT</i>
2	Calibrate 0 %	FUNC	You will see: <i>Upper Display: (a value)</i> (approximately 750) <i>Lower Display: ZERO VAL</i>
		▲ or ▼	Until the desired 0 % (4 mA) output is read on the milliammeter.
3	Calibrate 100 %	FUNC	Stores the 0 % value and you will see: <i>Upper Display: (a value)</i> (approximately 3650) <i>Lower Display: SPAN VAL</i>
		▲ or ▼	Until the desired 100 % (20 mA) output is read on the milliammeter.
4	Exit the Calibration Mode	FUNC	The recorder stores the span value.
		LOWR DISP or SET UP	To exit the calibration mode.



ATTENTION

The calibration for Auxiliary Outputs #2 and #3 follows the procedure for calibrating the current proportional output (*refer to Subsection 8.2*).

9. Troubleshooting / Service

9.1 Overview

**SHOCK HAZARD—WARNING!**

Disregard of these instructions may cause injury or death.

TROUBLESHOOTING MAY REQUIRE ACCESS TO HAZARDOUS LIVE CIRCUITS, AND SHOULD ONLY BE PERFORMED BY QUALIFIED SERVICE PERSONNEL. MORE THAN ONE SWITCH MAY BE REQUIRED TO DE-ENERGIZE UNIT BEFORE SERVICING.

Introduction

This section explains how to troubleshoot the DR4500A recorder using self-diagnostic test results and error messages as well as some visual failure symptoms. Using an optimum replacement unit repair philosophy, trouble is traced to a printed circuit board (PCB)/hardware assembly level rather than to an individual PCB/hardware assembly component. While troubleshooting is straightforward, we recommend that only trained service technicians repair the recorder.

What's in this section?

The following topics are covered in this section.

	Topic	See Page
9.1	Overview	203
9.2	Troubleshooting Aids	205
9.3	Self Diagnostics	207
9.4	Visual Failure Symptoms	213
9.5	Troubleshooting Procedures	214
9.6	Pen Alignment	220

Types of problems

Instrument performance can be adversely affected by installation and application problems as well as hardware problems. We recommend that you investigate the problems in the following order:

- Installation related problems
- Application related problems
- Hardware and software related problems

and use the information presented in this section to solve them.

If a replacement of any part is required, follow the instructions shipped with the replacement part.

Installation related problems

Read the Installation section in this manual to make sure the DR4500A has been properly installed. The installation section provides information on protection against electrical noise, connecting external equipment to the recorder, and shielding and routing external wiring.



ATTENTION

System noise induced into the recorder will result in diagnostic error messages recurring. If the diagnostic error messages can be cleared, it indicates a “soft” failure and is probably noise related.

If system noise is suspected, completely isolate the recorder from all field wiring. Use calibration sources to simulate PV and check all recorder and control functions; that is, Pen functions, Chart Trace, Gain, Rate, Reset, Output, Alarms, etc.

Application related problems

Review the application of the recorder; then, if necessary, direct your questions to the local sales office.

Hardware and software related problems

Use the troubleshooting error message prompts and recorder failure symptoms to identify typical failures which may occur in the recorder. Follow the troubleshooting procedures to correct them.

9.2 Troubleshooting Aids

Self diagnostics

The DR4500A recorder runs self-diagnostic tests to monitor the recorder's general health. The tests are divided into three main groups and will produce an error message when failed.

An error message can occur

- at power-up — run when power is cycled off and on,
- during continuous background tests while in normal operation, and
- when the Status Tests are requested by the operator.

Table 9-4 lists all the error message prompts that you could see, the reason for the failure, and how to correct the problem

Visual failure symptoms

Other failures may occur that deal with the power, pen functions, chart rotation, output, or alarms. Refer to the visual failure symptom in Table 9-5 to determine what is wrong and the troubleshooting procedures to use to correct the problem.

Check Installation

If a set of symptoms still persists, refer to *Section 2 - Installation* and ensure proper installation and proper use of the recorder in the system.

Customer support

If you cannot solve the problem using the troubleshooting procedures listed in this section, get the **model number** and **serial number** from the label on the chart plate, and **software** version (see "Determining the software version") then:

- call Customer Support Phone Number
1-800-423-9883 USA and Canada

If it is determined that a hardware problem exists and the recorder is still within the two year warranty, a replacement recorder will be shipped with instructions for returning the defective unit.

Determining the software version

Table 9-1 lists the procedure for identifying the software version number.

Table 9-1 Procedure for identifying the software version

Step	Operation	Press	Action/Result
1	Select STATUS Set Up Group	SET UP	Until you see: <i>Upper Display:</i> READ <i>Lower Display:</i> STATUS
2	Read the software version	FUNC	Until you see: <i>Upper Display:</i> (Software Version Number) <i>Lower Display:</i> VERSION Please give this number to the Customer Support person. It will indicate which version of DR4500A you have and help them determine a solution to your problem.

Troubleshooting

The troubleshooting procedures are divided into two parts:

- Self Diagnostics - Error Message Prompts, and
- Visual Failure Symptoms.

If a “Failed” indication is given for one of the power-up tests and/or an error message prompt blinks in the lower display, refer to the Self Diagnostic error message prompts.

If erratic operation is observed, refer to the Visual Failure symptoms.

In either case, run the status tests to verify the status of the recorder’s basic self-diagnostic tests.

9.3 Self Diagnostics

Power-up tests

When the recorder is powered-up, four tests are run by the DR4500A software to ensure memory integrity.

- As the tests are run, the displays appear as shown in Table 9-2.

Table 9-2 Power-up tests

Lower Display	Upper Display
RAM TEST	PASS or FAIL
CONFTEST (configuration checksum)	PASS or FAIL
CAL TEST (working calibration)	PASS or FAIL
BATTERY*	PASS or FAIL

*Battery test failure does not cause a failsafe.

Failsafe

- If control is configured, and any test—except BATTERY—fails, “FAIL” appears momentarily in the upper display, then a display test is run, after which the controller goes into manual mode and you will see:

Upper Display: (PV value)

Lower Display: FAILSAFE (blinking)

Refer to “*Device Status*” (next page) to determine which tests have failed and how to correct them.

- All applicable error messages are displayed in rotation. If "CONTROL" is not configured, FAILSAFE will not display. CNFG ERR, CAL1 ERR, CAL2 ERR, or BATT LOW will display, whether FAILSAFE does or not.

Error message prompts

The messages listed in Table 9-4 may appear during the power-up test or status test, or they may blink in the lower display as the result of ongoing background tests that verify data and memory integrity.

In the case of more than one simultaneous malfunction in the background tests, the failure messages will be displayed in rotation.

Table 9-4 lists the error message, the test group that prompted the message, the reason for the failure, and how to correct the problem.

Table 9-4 Error message prompts

Lower Display Indication	Test Group	Reason for Failure	How to Correct the Problem
FAILSAFE (Note 1) (Note 2)	Status or Background	This error message shows whenever the recorder goes into a failsafe mode of operation. This will happen if control is enabled and: <ul style="list-style-type: none"> • a power-up test fails, • a specific background test fails. (Failsafe will be displayed in rotation with other failure messages, except BATTERY, only if control is enabled.)	<ol style="list-style-type: none"> 1. Run through the "Device Status" check (page 208) to determine the reason for the failsafe indication. 2. Identify the other failure message in the display and correct the problem according to the recommendations given in this table for that particular error message.
RAM TEST (Note 1)	Power-up	RAM failure	<ol style="list-style-type: none"> 1. Cycle power. 2. Check "Device Status" (page 208) to see if error clears. 3. If error doesn't clear, replace the main printed circuit board.
CONFTEST (Note 1)	Power-up	Configuration data is in error.	<ol style="list-style-type: none"> 1. Check all the configuration prompts for accuracy. <ul style="list-style-type: none"> • See <i>Section 3 - Configuration</i> for selections and limits. 2. Change <i>any</i> configuration item, check "Device Status" to see if CONFTEST = PASS, return configuration item to original value. <ul style="list-style-type: none"> • See <i>Section 3 - Configuration</i> for instructions to change a configuration item.

Lower Display Indication	Test Group	Reason for Failure	How to Correct the Problem
CNFG ERR	Background	Configuration data is in error.	<ol style="list-style-type: none"> 1. Check all the configuration prompts for accuracy. <ul style="list-style-type: none"> • See <i>Section 3 - Configuration</i> for selections and limits. 2. Change <i>any</i> configuration item, then return it to the original value. <ul style="list-style-type: none"> • See <i>Section 3 - Configuration</i> for instructions to change a configuration item.
CAL TEST (Note 1)	Power-up	The working calibration constants in the recorder are in error.	<ol style="list-style-type: none"> 1. Change to a different input type. <ul style="list-style-type: none"> • See <i>Section 3 – Configuration</i>. 2. Check “Device Status” (page 208) to see if FACT CRC = PASS. <ul style="list-style-type: none"> • If PASS—return to original input type. • If FAIL—field calibrate. Refer to <i>Section 7 – Input Calibration</i>.
CAL1 ERR	Background	Working CAL TEST failure (Control 1, Input 1, Input 2)	<ol style="list-style-type: none"> 1. Change to a different input type. <ul style="list-style-type: none"> • See <i>Section 3 – Configuration</i>. 2. Check “Device Status” (page 208) to see if FACT CRC = PASS. <ul style="list-style-type: none"> • If PASS—return to original input type. • If FAIL—field calibrate Control Output #1, Input 1, or Input 2. Refer to <i>Section 7 – Input Calibration</i> and <i>Section 8 – Output Calibration</i>.
CAL2 ERR	Background	Working CAL TEST failure (Control 2, Output)	<ol style="list-style-type: none"> 1. Field calibrate Control Output 2. <ul style="list-style-type: none"> • Refer to <i>Section 8 – Output Calibration</i>.
FACT CRC	Check “Device Status” See page 208.	Factory-set input constants have been changed due to the change in input type.	<ol style="list-style-type: none"> 1. Check background test error message being displayed. 2. Recalibrate Input or Output. <ul style="list-style-type: none"> • Refer to <i>Section 7 – Input Calibration</i> or <i>Section 8 – Output Calibration</i>.

Lower Display Indication	Test Group	Reason for Failure	How to Correct the Problem
EE FAIL	Background	Unable to write to nonvolatile memory. Any time you change a parameter and it is not accepted, you will see EE FAIL.	<ol style="list-style-type: none"> 1. Check the accuracy of the parameter and re-enter. 2. Try to change something in configuration. 3. Call Customer Support 1-800-423-9883 USA and Canada.
IN1 FAIL IN2 FAIL	Background	Two consecutive failures of input 1 integration (for example, cannot make analog to digital conversion)	<ol style="list-style-type: none"> 1. Be sure the range and actuation are configured correctly. 2. Check the input source. 3. Recalibrate. Refer to <i>Section 7 - Input Calibration</i>. 4. Replace the input card. 5. Call Customer Support 1-800-423-9883 USA and Canada.
BATTERY	Power-up or Status	Battery test failure.	<ol style="list-style-type: none"> 1. Replace battery. 2. Call Customer Support 1-800-423-9883 USA and Canada
BATT LOW	Background		
PV LIMIT	Background	Process Variable is out of range. $\pm 10\%$ of range	<ol style="list-style-type: none"> 1. Be sure pen input configuration is correct. 2. Check the displayed PV value to see if it is outside input limits. 3. Call Customer Support 1-800-423-9883 USA and Canada.
RV LIMIT	Background	<p>The result of the formula shown below is beyond the range of the remote variable.</p> $RV = INP2 \times RATIO + BIAS$	<ol style="list-style-type: none"> 1. Make sure the input signal is correct. 2. Make sure the ratio and bias settings are correct. 3. Go to CONTROL prompt REMOTE SOURCE and change REMOTE to 1LOCAL.

Lower Display Indication	Test Group	Reason for Failure	How to Correct the Problem
<p>IN1RNG IN2RNG</p>	<p>Background</p>	<p>Input out of range. The process input is outside the range limits.</p>	<ol style="list-style-type: none"> 1. Make sure the range and actuation are configured properly. 2. Check the input source. 3. Restore the factory calibration: <ol style="list-style-type: none"> a) Disconnect the wiring from the terminals on plug J2 on the input board (see Figure 2-13). Place a jumper across these terminals. The controller should read room temperature if it is configured for a thermocouple input. b) If it does not read room temperature, see <i>Section 3 - Configuration</i> and change the IN1TYP prompt in the INPUT 1 group to another type of thermocouple. c) After the change, press FUNC key, then the LOWR DISP key. The controller should read the correct room temperature. If it does not, the unit has an input failure. d) Repeat step b. This time switch the IN1TYP back to the originally selected thermocouple. e) Repeat step c. The controller is restored with factory calibration. f) Remove the jumper and reconnect the thermocouple to plug J2. 4. Field calibrate. See <i>Section 7 – Input Calibration</i>. 5. Replace the input card. 6. Call Customer Support 1-800-423-9883 USA and Canada.

NOTE 1: Will appear in “STATUS” Set Up Group—See procedure for displaying the test results on page 208.

NOTE 2: Will also appear in rotation with other background test failure error messages.

9.4 Visual Failure Symptoms

Introduction

In addition to the error message prompts, there are visual failure symptoms that can be identified by noting the erratic recorder functions.

Symptoms

Compare your symptoms with those shown in Table 9-5 and refer to the troubleshooting procedure indicated to correct the problem.

Table 9-5 Visual failure symptoms

Symptom	Troubleshooting Procedure
Recorder will not operate	1
Recorder operation is normal but pen trace is incorrect	2
Chart rotates at wrong speed or will not rotate (pen indication correct)	3
Pen remains at high end of range when input signal is low	4
Pen does not move when input signal changes	5
A key does not respond and/or a display does not light	6
Displayed output does not agree with controller output	
Current Proportional Output Type	7
Position Proportional Output Type	8
Single or Dual Relay Output Type	9
Duplex Current/Time or Time/Current Proportional Output Type	10
Auxiliary Output Type	11
External Alarm Function does not operate properly	12
Modbus Communications Failure	13

9.5 Troubleshooting Procedures

Introduction

The troubleshooting procedures for the Visual Failure Symptoms are listed in numerical order as they appear in Table 9-5. Each procedure lists what to do if you have that particular failure and how to do it or where to find the data needed to accomplish the task. Progressive steps provide aid in finding and fixing the problem.

Equipment needed

You will need the following equipment in order to troubleshoot the symptoms listed in the tables that follow:

- DC Milliammeter – mA_{dc}
- Calibration sources – T/C, mV, Volt, etc.
- Voltmeter

Table 9-6 Procedure #1—Troubleshooting recorder failure symptoms

Step	What to do	How to do it or where to find the data
1	Check the fuse on the main printed circuit board.	Replace if defective.
2	Check the supply voltage.	Measure the line voltage across J10 on the Main printed circuit board.
3	Check the connections to J10 on the main printed circuit board.	Refer to <i>subsection 2.6 - Input Wiring Procedures, (Figure 2-12 AC Line Power Wiring)</i> .
4	Check the transformer leadwire connections to the main printed circuit board.	Refer to Figure 10-5 in <i>Section 10 - Parts List</i> .
5	Check the system for brown-outs, heavy load switching, etc., and conformance to installation instructions.	Refer to <i>Section 2 - Installation</i> .
6	Replace the transformer.	Disconnect the transformer lead wires from the main printed circuit board. Replace the transformer and tighten the screws. Connect the lead wires to the main printed circuit board.
7	Call Technical Assistance Center.	1-800-423-9883 USA and Canada

Table 9-7 Procedure #2—Troubleshooting pen trace failure symptoms



WARNING

Do not lubricate the plastic gears on the chart and pen motors.

Step	What to do	How to do it or where to find the data
1	Check the sensor for the proper type and its ability to function.	Verify the input configuration data and operation of the sensor.
2	Recalibrate the recorder.	Refer to <i>Section 7 - Input Calibration</i> . For thermocouple input, be sure to confirm cold-junction temperature calibration.
3	Replace the servo plate assembly.	Refer to the instructions included with the replacement part.
4	Call Technical Assistance Center.	1-800-423-9883 USA and Canada

Table 9-8 Procedure #3—Troubleshooting chart rotation failure symptoms



WARNING

Do not lubricate the plastic gears on the chart and pen motors.

Step	What to do	How to do it or where to find the data
1	Check the chart installation.	Be sure the drive pin on the hub is in the drive hole on the chart.
2	Check the configured chart speed value and change it, if required.	Refer to <i>Section 3 - Configuration</i> .
3	Check the motor cable plug connection at connector J7 on the main printed circuit board.	Visually examine the plug and reset it.
4	Replace the chart motor.	Refer to the instructions included with the replacement part.
5	Call Technical Assistance Center.	1-800-423-9883 USA and Canada

Table 9-9 Procedure #4—Troubleshooting erratic pen movement symptoms



WARNING

Do not lubricate the plastic gears on the chart and pen motors.

Step	What to do	How to do it or where to find the data
1	Check the sensor and lead wires for continuity. Check the connections.	Replace the sensor lead wires as needed. Tighten the connections.
2	Check the pen and input configuration data.	Refer to <i>Section 3 - Configuration</i> .
3	Replace the servo plate assembly.	Refer to the instructions included with the replacement part.
4	Call Technical Assistance Center.	1-800-423-9883 USA and Canada

Table 9-10 Procedure #5—Troubleshooting pen failure symptoms



WARNING

Do not lubricate the plastic gears on the chart and pen motors.

Step	What to do	How to do it or where to find the data
1	Check the sensor and lead wires for continuity. Check the connections.	Replace the sensor lead wires as needed. Verify and tighten the input connections.
2	Check the pen arm for secure mechanical attachment to the servo shaft.	Verify that the flat-head screw that attaches the pen arm to the plastic servo gear on the servo shaft is tight.
3	Check the servo cable plug connection (J6) on the main printed circuit board.	Visually examine the plug and reseal it.
4	Replace the servo plate.	Refer to the instructions included with the replacement part.
5	Call Technical Assistance Center.	1-800-423-9883 USA and Canada

Table 9-11 Procedure #6—Troubleshooting keyboard and/or display failure symptoms

Step	What to do	How to do it or where to find the data
1	Run a Key Test to check the operation of the keys and displays.	Refer to <i>Section 5 - Operation</i> for procedures on running a key test.
2	Replace the membrane switch (keyboard) and /or display printed circuit board as required.	Refer to the instructions included with the replacement part.

Table 9-12 Procedure #7—Troubleshooting current proportional output failure symptoms

Step	What to do	How to do it or where to find the data
1	Be sure the recorder is configured for current output.	Refer to <i>Section 3 - Configuration</i> . Make sure OUT ALG selection = CURRENT.
2	Check the field wiring.	Refer to <i>Section 2 - Installation</i> .
3	Be sure all the recorder and control related data is correct.	Refer to <i>Section 3 - Configuration</i> . Check the tuning, algorithm, and control data.
4	Check the output.	Put the recorder into Manual Mode and raise/lower the output manually from 0% to 100% (4–20 mA). Use a milliammeter at connection J1 on the control output printed circuit board.
5	Recalibrate the current proportional output.	Refer to <i>Section 8 - Output Calibration</i> .
6	Replace the control output printed circuit board.	Refer to the instructions included with the replacement part.

Table 9-13 Procedure #8—Troubleshooting position proportional output failure symptoms

Step	What to do	How to do it or where to find the data
1	Be sure the recorder is configured for position proportional output.	Refer to <i>Section 3 - Configuration</i> . Make sure OUT ALG selection = POSITN.
2	Check the field wiring.	Refer to <i>Section 2 - Installation</i> .
3	Check the output.	Put the recorder into manual mode and adjust the output manually to drive the motor from 0% to 100%.
4	Check whether the motor drives in both directions. If it does, go to step 5. If the motor drives in one direction only, check the slidewire. If the motor does not drive in either direction, check the motor.	Refer to <i>Section 8 - Output Calibration</i> for motor slidewire calibration. Refer to the motor instructions.
5	Check the output voltage to the slidewire.	Put the voltmeter across the slidewire terminals at connector J2 on the control output printed circuit board and check that the slidewire voltage varies with the motor position.
6	Be sure that the output relays are actuating properly. If they are not, check the field wiring, then go to step 4. If they are, go to step 7.	Put the recorder into manual mode and adjust the output manually above and below the present value. Listen for the click of the relays. One relay should click when the output is adjusted higher, and the other should click when the output is adjusted lower than the present value. Observe OUT 1 and 2 indicators on the front display.
7	Check the control relay jumper position.	Refer to <i>Section 3 - Configuration</i> .
8	Replace the control output printed circuit board.	Refer to the instructions included with the replacement part.
9	Recalibrate the position proportional output.	Refer to <i>Section 8 - Output Calibration</i> .

Table 9-14 Procedure #9—Troubleshooting relay output failure symptoms

Step	What to do	How to do it or where to find the data
1	Be sure the recorder is configured for relay output.	Refer to <i>Section 3 - Configuration</i> . Make sure OUT ALG selection = TIME.
2	Be sure all the recorder and control related data is correct.	Refer to <i>Section 3 - Configuration</i> . Check the Tuning, Algorithm, and Control data.
3	Check that the applicable output relay actuates properly. If it does, go to step 4.	Put the recorder into manual mode and adjust the output manually to raise or lower the PV around the setpoint. Listen for the click of the relay as the PV moves in either direction. Observe OUT 1 or 2 indicator on the front display.
4	Check the control relay jumper positions.	Refer to <i>Section 3 - Configuration</i> .
5	Check the field wiring.	Refer to <i>Section 2 - Installation</i> .
6	Replace the control output printed circuit board.	Refer to the instructions included with the replacement part.

Table 9-15 Procedure #10—Troubleshooting current/time or time/current failure symptoms

Step	What to do	How to do it or where to find the data
1	Be sure the recorder is configured for current time/time current output.	Refer to <i>Section 3 - Configuration</i> . Make sure OUT ALG selection = TI CUR or CUR TI.
2	Be sure all the recorder and control related data is correct.	Refer to <i>Section 3 - Configuration</i> . Check the tuning, algorithm, and control data.
3	Check that the applicable output relay actuates properly. If it does, go to step 4. If it does not check the field wiring; then go to step 5.	Put the recorder into manual mode and adjust the output manually to raise or lower the PV around the setpoint. Listen for the click of the relay as the PV moves in either direction. Observe OUT 1 or 2 indicator on the front display.
4	Check the control relay jumper positions.	Refer to <i>Section 3 - Configuration</i> .
5	Check the current proportional output.	Put the recorder in manual mode and manually adjust the output from 0 to 100% (4–20 mA). Use a milliammeter across the terminals in connector J1 on the control output printed circuit board to verify the output.
6	Recalibrate the current output.	Refer to <i>Section 8 - Output Calibration</i> .
7	Replace the control output printed circuit board.	Refer to the instructions included with the replacement part.

Table 9-16 Procedure #11—Troubleshooting the auxiliary output

Step	What to do	How to do it or where to find the data
1	Be sure the controller is configured for Auxiliary Output.	Refer to <i>Subsection 3.15 – Auxiliary Output Set Up Group</i> . Make sure AUX OUT is enabled and the correct parameter is chosen. Check the High and Low Scale values.
2	Check the field wiring.	Refer to <i>Section 2 – Installation</i> .
3	Check the output.	Use a milliammeter at connection J2 on the Auxiliary Output printed circuit board to determine the correct output based on your representation of 4 mA and 20 mA.
4	Recalibrate the Auxiliary Output.	Refer to <i>Subsection 8.4 – Auxiliary Output Calibration</i> .
5	Replace the Auxiliary Output printed circuit board.	Refer to the instructions included with the replacement part.

Table 9-17 Procedure #12—Troubleshooting external alarm function failure symptoms

Step	What to do	How to do it or where to find the data
1	Be sure all the alarm configuration data is correct.	Refer to <i>Section 3 - Configuration</i> .
2	Check the applicable alarm relay jumper position.	Refer to <i>Section 3 - Configuration</i> .
3	Check the field wiring.	Refer to <i>Section 2 - Installation</i> .
4	Check that the applicable alarm relay actuates properly depending on ALARM TYPE configuration selection.	Alarms can be triggered either by: <ul style="list-style-type: none"> • reconfiguring the value of the trip points (AnSnVAL), or • connecting a signal generator to the input and setting the generator level beyond the trip-point values.

Table 9-18 Procedure #13—Troubleshooting Modbus communications failure symptoms

Step	What to do	How to do it or where to find the data
1	Check the field wiring and termination resistor.	Refer to Figure 2-21 in <i>Section 2 – Installation</i> in this manual.
2	Make sure the Modbus Communications board is properly installed in the recorder.	Open the recorder door and chart plate, and inspect the board. Refer to Figure 10-4 for location of the board.
3	Run a Loopback test.	Refer to Modbus Communications manuals 51-52-25-66 and 51-52-25-69 for loopback information.

9.6 Pen Alignment

Mechanical alignment



CAUTION

Align pens mechanically as shown in Table 9-19 and then electrically as described in Table 9-20. Never attempt to manually force the pen arms from the front, since this will damage the pen mechanism.



ATTENTION

Be sure the shipping sponge is installed on the pen tip whenever the recorder is moved or stored.

Table 9-19 Pen 1 (purple) and Pen 2 (red) Mechanical Alignment

Step	Action
1	Refer to Figure 9-1. ATTENTION: If you only have a one pen recorder, steps for pen 2 (red) do not apply.
2	Turn off power, open the door, and lift the pen lifter up.
3	Unclip and remove the purple and red ink cartridges from pen 1 and 2 arms to provide a better view of tips of arms.
4	Push the No. 1 pen sector gear down so that its uppermost teeth mesh with teeth on the motor shaft gear.
5	Push the No. 2 pen sector gear up until it is at the top of the slot in the servo plate.
6	<i>For the 2 Pen Recorder:</i> Remove the screw and lockwasher holding the No. 1 pen arm to the servo shaft. Slightly loosen the screw holding the No. 2 pen arm to the servo shaft. <i>For the 1 Pen Recorder:</i> Slightly loosen the screw holding the No. 1 pen arm to the servo shaft and skip to Step 8.
7	Move the No. 2 pen arm so that its right tip aligns with the inside circumference of the inner most circle in the center of the chart. Tighten the screw.
8	Replace the No. 1 pen arm, lockwasher, and screw, but leave the screw slightly loose.
9	Move the No. 1 pen arm so that its right tip aligns with the inside circumference of the inner most circle in the center of the chart. Tighten screw.

Figure 9-1 is a graphic view of the mechanical alignment of pens.

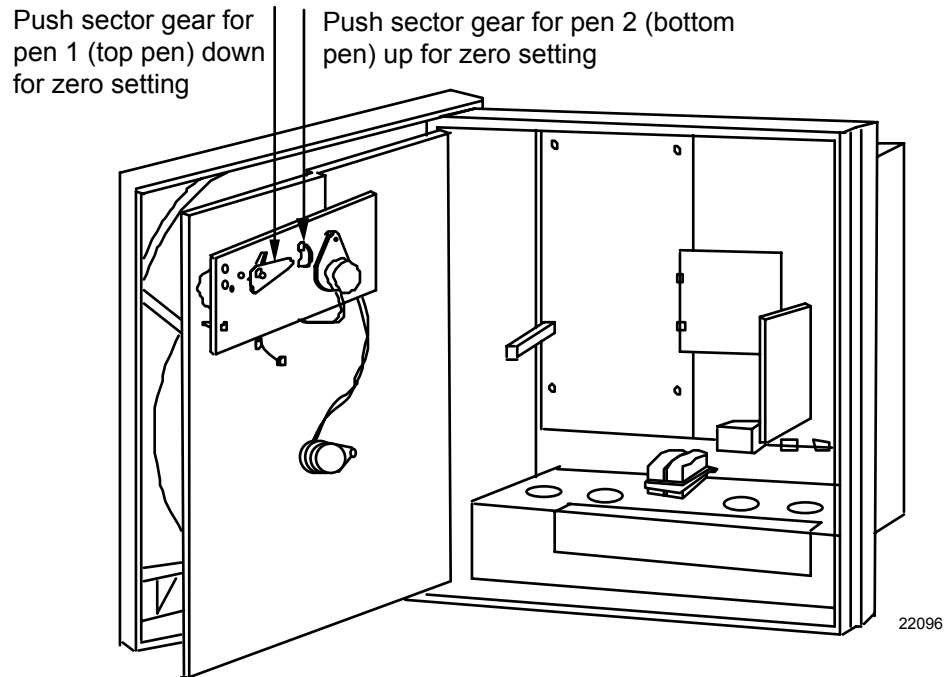


Figure 9-1 Mechanical Alignment of Pens

Electrical alignment

If the group prompt “LOCKOUT” has been configured for “CALIB” or “MAX” selection, you will not be able to access PEN 1 or PEN 2 group prompt for electrical alignment. See *Section 3 – Configuration* to set LOCKOUT to “NONE”.



ATTENTION

PEN 1 and PEN 2 must be aligned separately. However, the keystroke sequence is the same for both pens, but the prompts change from PEN 1 to PEN 2. Be sure that the number of the pen displayed in the prompt agrees with the number of the pen being aligned. If you only have a one-pen recorder, the PEN 2 prompts do not apply.

Align the pens electrically as shown in Table 9-20.

Table 9-20 Set the chart time line procedure

Step	Press	Action/Result
1		Open the door, apply power, and wait for the recorder to run its power up tests.
2	SET UP	Until you see: <i>Upper Display: ALIGN</i> <i>Lower Display: PEN 1</i>
3	FUNC	You will see: <i>Upper Display: ALIGN</i> <i>Lower Display: PEN 10</i> The pen moves to an internal stop then backs away and stops.
	▲ or ▼	To move the pen to the zero position on the chart (inner position of chart). ATTENTION: You can position the pen over 100 steps. Those steps are relative units only. Step 0.0 is the innermost position on the chart, and step 1200 is the highest circumference position.
4	FUNC	You will see: <i>Upper Display: ALIGN</i> <i>Lower Display: PEN 100</i> The value adjusted in Step 3 is entered into memory.
	▲ or ▼	To raise or lower the value in the upper display (up to 1200) move the pen to the highest chart range value (outer circumference printed on the chart).
5		Repeat steps 2 through 4 for pen 2 or press LOWR DISP key to return to normal operation and enter the span value into memory.

10. Parts List

10.1 Overview

Introduction

This section provides the replacement parts lists for the DR4500A Classic Series Recorder. Most parts are supplied on an optimum replacement unit basis; that is, part numbers are given for complete printed circuit boards rather than for individual PCB components.

The figures that follow are exploded views of the DR4500A recorder. Each part is labeled with a key number and the key numbers are listed in tables with associated part number.

Also included for your reference are an Internal Cabling drawing (Figure 10-5) and an Internal Wiring Diagram (Figure 10-6) for options only.

When ordering parts, be sure to specify your recorder's serial and model numbers (on nameplate) as well as the part identification.

What's in this section?

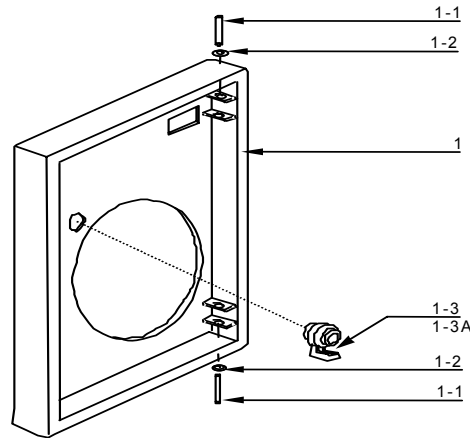
This section contains the following topics:

Topic		See Page
10.1	Overview	223
10.2	Exploded Views	224
	Figure 10-1 Door assembly	224
	Figure 10-2 Chart plate assembly	225
	Figure 10-3 Basic recorder components without options	227
	Figure 10-4 Recorder components associated with options	229
10.3	Miscellaneous Hardware Kit Contents	231
10.4	Figure 10-5 Internal Cabling Data	232
10.5	Figure 10-6 Internal Wiring Diagram – Options Only	233

10.2 Exploded Views

Door assembly

Figure 10-1 is an exploded view of the Door Assembly. Table 10-1 is a list of the associated part numbers.



21452C

Figure 10-1 Door assembly

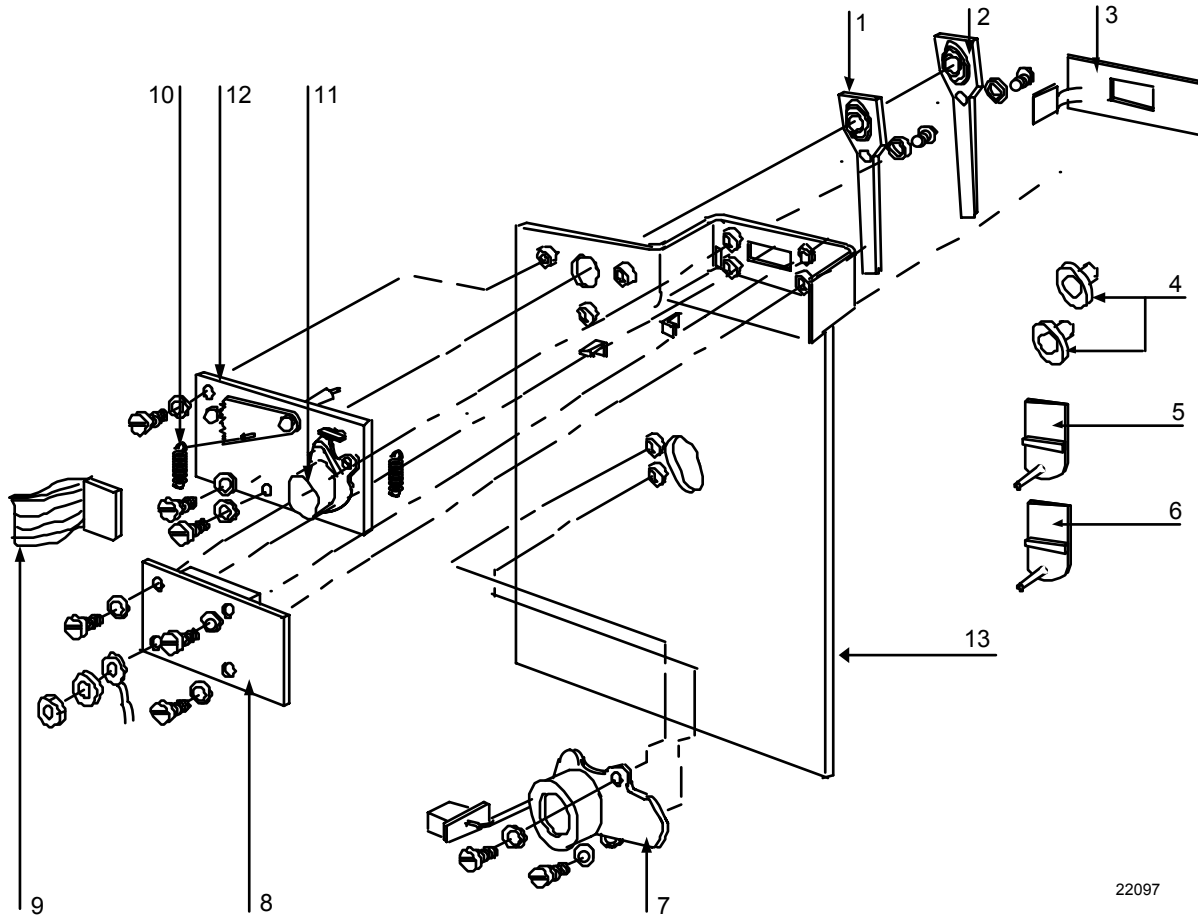
Table 10-1 Door assembly parts

Key	Part Number	Description	Recommended Spare Parts per		Quantity per Unit
			10	100	
1 (Note 3)		Door Assembly			1
	30754955-501	Blue with glass window and latch			
	30754955-504	Blue with acrylic window and latch			
	30754955-505	Gray with glass window and latch			
	30754955-506	Gray with acrylic window and latch			
	30754955-507	Black with glass window and latch			
	30754955-508	Black with acrylic window and latch			
	51452435-501	NEMA4X Door with Plastic window			
51452435-502	NEMA4X Door with Glass window				
51452435-503	NEMA4X Door with HTST window				
1-1	(K)30755980-001	Hinge Pin (Note 1)			2
1-2	(K)30755980-001	Retaining Ring (Note 1)			2
1-3	51309609-503	Latch/Lock Assembly Kit	1	3	1
1-3A	30755980-006	Key kit for keyed latch or lock			
	51404929-501	External Keypad Upgrade Kit (not shown)			1

NOTE 1: For Door 30754955-50X, (K) denotes that these parts are included in the miscellaneous hardware kit 30755980-001. For all other doors, the parts are included with applicable door assembly.

Chart plate

Figure 10-2 is an exploded view of the Chart Plate Assembly.
Table 10-2 is a list of the associated part numbers.



22097

Figure 10-2 Chart plate assembly

Table 10-2 Chart plate assembly parts

Key	Part Number	Description	Recommended Spare Parts per		Quantity per Unit
			10	100	
1	(K)30755980-002	No. 2 pen arm (two pen model only)	1	5	1
2	(K)30755980-002	No. 1 pen arm	1	5	1
3	30754957-501	Membrane switch keypad	1	5	1
4	(K)30756150-001	Chart Hub Kit	1	3	2
5	30735489-007	No. 1 purple pen cartridge (six pack)	2	5	1
6	30735489-002	No. 2 red pen cartridge (six pack)	2	5	1
7	30756113-501	Chart motor	1	3	1
8	30757571-501	Display PCB (includes key no. 9)	1	5	1
9	See above	Ribbon cable, display (included with key no. 8)	1	3	1
10	(K)30755980-002	Spring, tension			1
11	See above	Servo motor assembly (included with key no. 12)	1	3	1
12	30754975-501 30754975-502	Servo plate assembly (includes key no. 11) – 1 pen model – 2 pen model	1	2	1
13	30754977-501 30754977-502 30754977-511 30754977-512	Chart plate – 1 pen model – 2 pen model – 1 pen model—CE Mark – 2 pen model—CE Mark			1

Basic recorder components without options

Figure 10-3 is an exploded view of the basic recorder components.
Table 10-3 is a list of the associated part numbers.

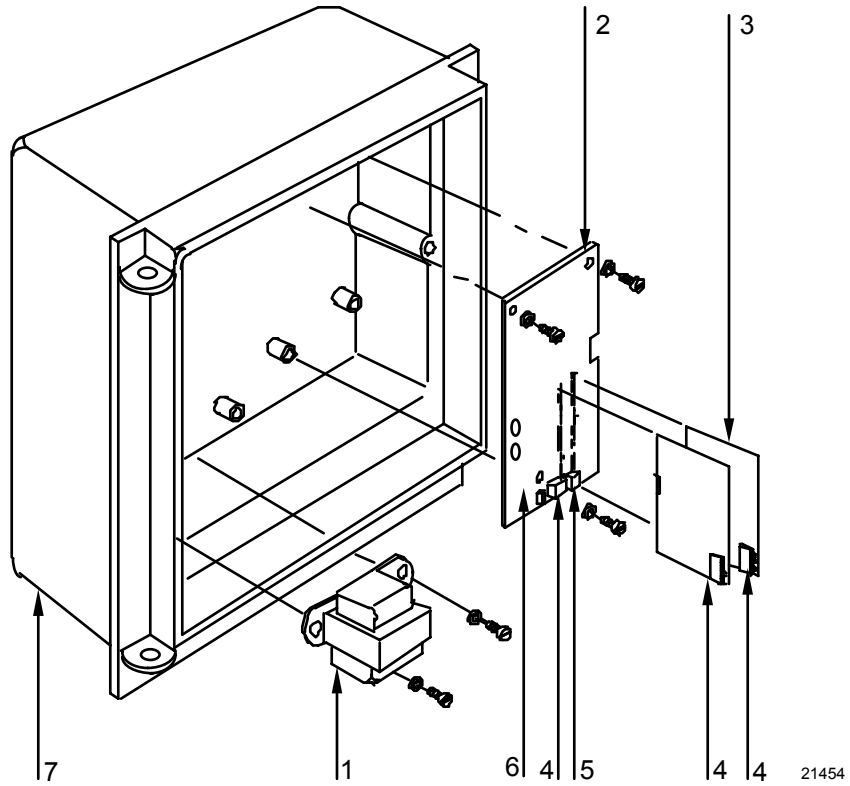


Figure 10-3 Basic recorder components without options

Table 10-3 Basic recorder parts without options

Key	Part Number	Description	Recommended Spare Parts per		Quantity per Unit
			10	100	
1	30754982-502	Main Transformer	1	3	1
2	51309355-501	Main PCB	1	5	1
3	(K)30756141-003	Input PCB (input 1 or 2)			1/3
4	See Note 2	3-position connector**			2
5	See Note 2	2-position connector**			1
6	(K)30755980-005	Fuse (Wilkman 19374-K 500 ohm or equal)**			1
7	30754924-502	Case			1
PARTS NOT SHOWN					
	See Note 2	Card guides for Input PCBs**			2
	51197612-502 51197612-503	Ferrite Filter - Package of 2 (CE Mark) Ferrite Filter - Package of 8 (CE Mark)			1
	51197650-501	Washer Kit (package of 6)			1
	51197755-001	Capacitor Kit (.01mfd) - 12 per kit (CE Mark)			
	30755232-502	0-10 Vdc Input Divider (input PCBs)			*
	30756461-002	250 ohm Resistor Assembly			*
	(K)30755065-501 (K)30755065-503	Mounting Kit (standard) Mounting Kit (NEMA4X)			1
	(K)30755134-001 (K)30755134-002	Blue Universal Filler Plate Kit Gray Universal Filler Plate Kit			*
	(K)30755011-001	Filler Panel Kit (for replacing Servoline recorder)			*
	(K)30757205-008	Kit to Upgrade/Add Totalization to Inputs #1 and #2 for Classic Recorder			*
	51198150-501	Pipe Mounting Kit 2" Pipe Size			1
	51197657-501 51197657-502	Panel Mounting Gasket Kit (standard) Panel Mounting Gasket Kit (NEMA4X)			1

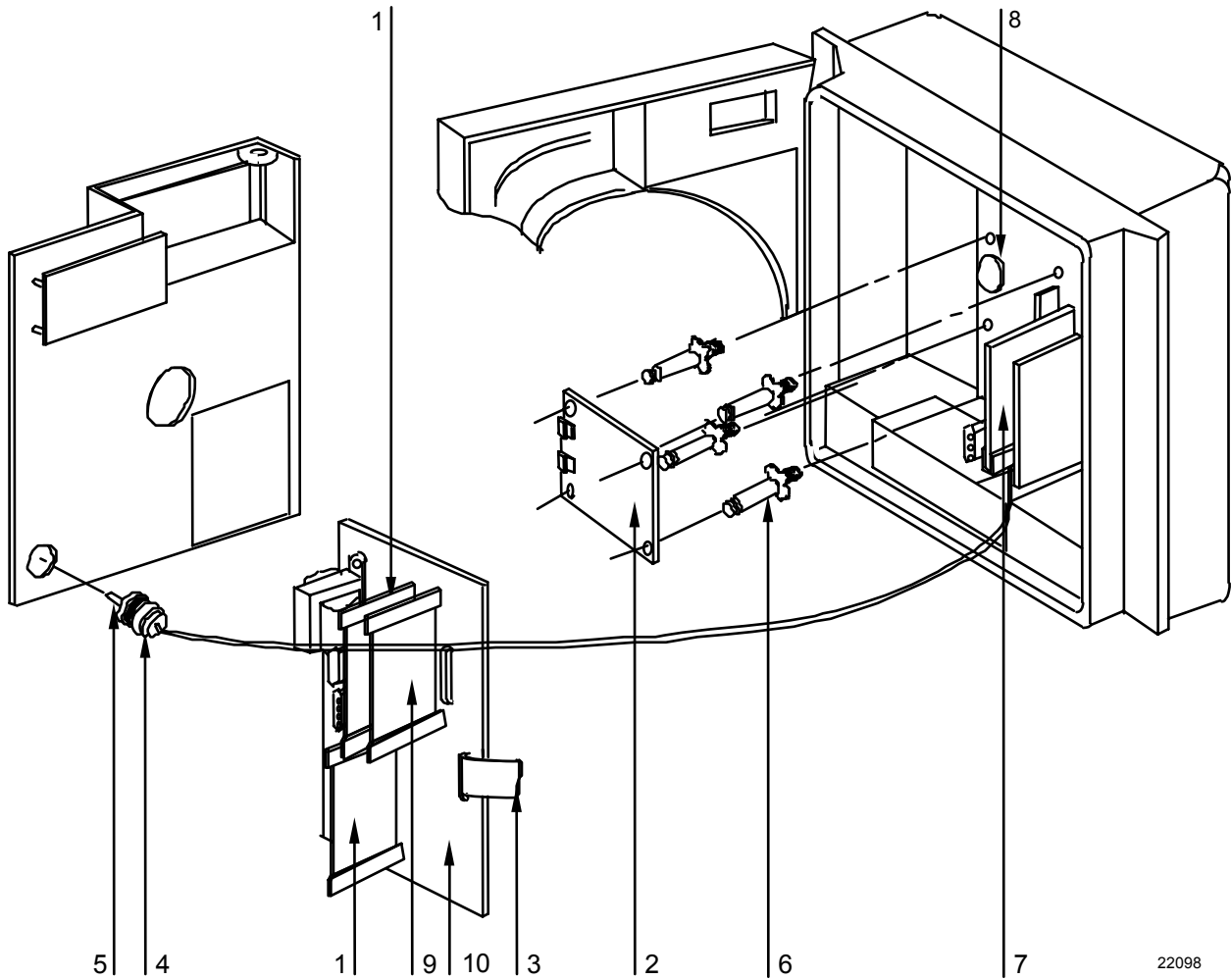
NOTE 2: These parts are included with applicable PCB kits, as required.

* As required

** These parts are also included in the miscellaneous hardware kit 30755980-003

Additional recorder components associated with options

Figure 10-4 is an exploded view of the recorder components associated with options.
Table 10-4 is a list of the associated part numbers.



22098

Figure 10-4 Recorder components associated with options

Table 10-4 Recorder parts associated with options

Key	Part Number	Description	Recommended Spare Parts per		Quantity per Unit
			10	100	
1	30754922-501 30754922-502	Control Output #1 or #2 PCB For FM Approved Output PCB	1	5	1
2	(K)30756140-001	Alarm output/digital input PCB kit			1
3	See Note 3 30755119-501	Ribbon cable (34-conductor)	1	3	1
4	30755127-502	Light accessory kit			1
5	(K)30749598-501	Kit of 5 Bulbs (General Instruments 1828 or equivalent)			1
6	30732192-502	Spacer	1		4
7	(K)30756141-003	Input PCBs (optional second input)		5	1/2
8	(K)30755980-004	Battery (Duracell DL2450 or equivalent)	1	3	1
9	51404561-501 51404561-502 51404561-503	Auxiliary Output PCB* RS485 Modbus RTU Communications PCB* RS485 Modbus RTU plus Auxiliary Output PCB*	1	5	1
10	30754919-501	Mother board	1	3	0/1
PARTS NOT SHOWN					
	(K)30757301-001	Configuration Lockout Hardware			1

NOTE 3: Part included with alarm output/digital input PCB kit 30756140-001.

*Includes connectors and standoffs as required.

10.3 Miscellaneous Hardware Kit Contents

Kit contents

Table 10-5 lists the kit contents of miscellaneous hardware kit — part number 30755980-TAB.

Table 10-5 Miscellaneous hardware kit

Part Description	Quantity					
	Tab 001	Tab 002	Tab 003	Tab 004	Tab 005	Tab 006
Pen lifter/retainer		1				
Screw 10-32, 3/4" lg.		5				
O-ring		5				
Spring, tension		2				
Hinge pin	2					
Retaining ring	2					
Pen arm #1 (classic)		1				
Pen arm #2 (classic)		1				
Latch without lock	1					
Latch pin	1					
Latch gasket	1					
Card guide			2			
4-position connector			2			
3-position connector			2			
3-position connector—CE Mark			2			
2-position connector			2			
Fuse 0.5 A, 250 V					20	
Batteries 3.0 V Lithium Button Cell				5		
Key for latch or lock						1
Key for Heavy Duty Door/Keyed latch						1

10.4 Internal Cabling Data – Without Options

View of internal cabling

Figure 10-5 is a view of the internal cabling for the DR4500A Classic Series Recorder.

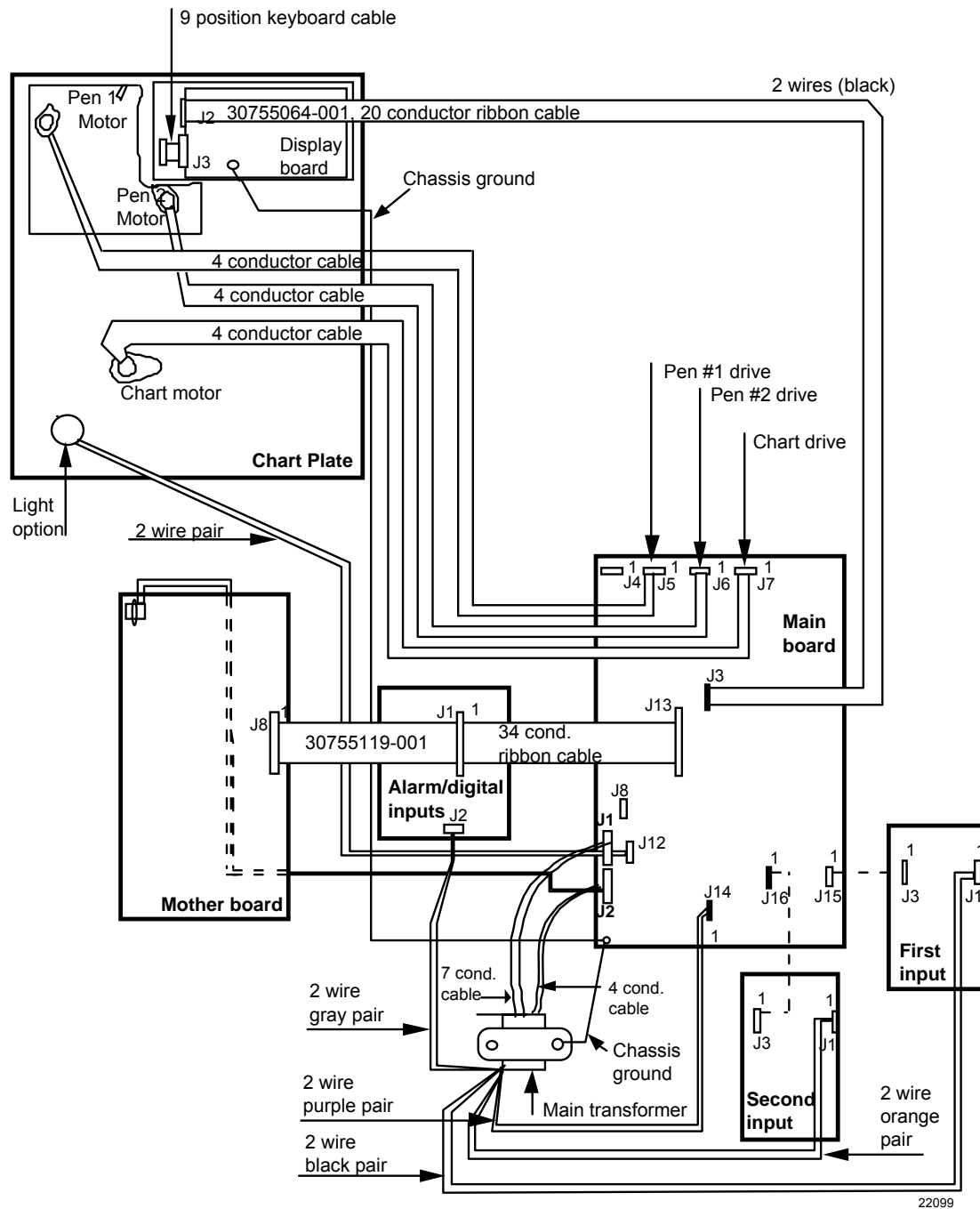


Figure 10-5 Internal cabling for DR4500A Classic recorder

10.5 Internal Wiring Diagram – Options Only

View of internal option wiring

Figure 10-6 is a view of the internal wiring diagram—options only for the DR4500A Classic Recorder.

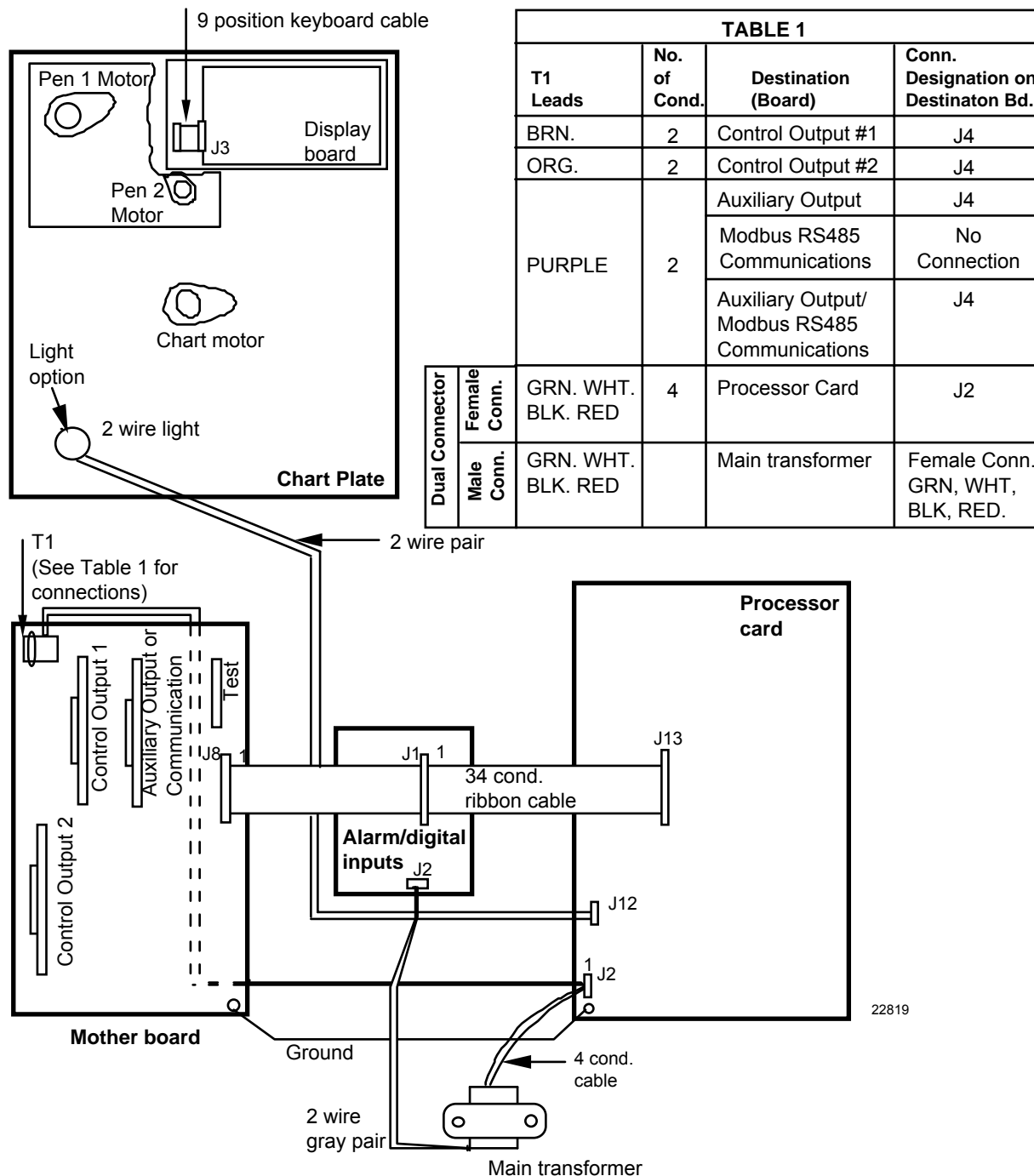


Figure 10-6 Internal diagram for DR4500A Classic recorder – options only

A. Foreign Language Safety Instructions

SIKKERHESKRAV

DA2I-6057



For at undgå elektrisk stød med mulighed for personskade, skal alle sikkerhedsbestemmelser i denne manual følges nøje.



Dette symbol advarer brugeren om en potentiel berøringsfare, såfremt der kan være adgang til den livsfarlige netspænding.



Beskyttende jordterminal. Terminalen er forberedt for og skal forbindes til beskyttelsesjordledning i henhold til stærkstrømsberkendtgørelsen (DK).

- Hvis udstyret ikke bruges som specificeret i manualen, kan den beskyttelse udstyret yder blive nedsat eller forsvinde.
- Eerstat kun komponenter som udtrykkeligt er specificeret som udskiftelige i manualen.
- Alle ledningsforbindelser skal følge stærkstrømsberkendtgørelsen (DK) og udføres af autoriseret erfarent personel.
- Den beskyttende jordterminal skal forbindes først af alle forbindelser (og fjernes som den sidste).
- Det anbefales jvf. stærkstrømsberkendtgørelsen, at der installeres en afbryder til frosyningsspændingen nær udstyret.

UDSTYRS SPECIFIKATIONER

Strømforsyning	102 til 132 Vac - 204 til 264 Vac
Frekvens	49 til 51 Hz - 59 til 61 Hz
Nominel effekt	9 watts max.

OMGIVELSES SPECIFIKATIONER

Placer ikke udstyret i nærheden af brandbare væsker eller dampe.

Temperatur	Rumtemperatur : 15 til 55°C
Fugtighed	10 til 90% RH
Vibration	0 til 70 Hz acceleration 0.1 g

UDSTYRS INSTALLATION

Skriveren skal monteres i en tavle for at forhindre adgang til bagterminaler.

VEILIGHEIDSVEREISTEN

DU2I-6057



Ter vermindering van het gevaar van elektrische schokken die lichamelijk letsel kunnen veroorzaken, dient u alle veiligheidsaanwijzingen in dit document te volgen.



Dit symbool waarschuwt de gebruiker voor een potentieel schokgevaar wanneer toegang bestaat tot onderdelen die onder gevaarlijke spanning staan.



Beschermende aarde-aansluiting. Bestemd voor aansluiting van de aardingsdraad van de voeding.

- Indien de apparatuur wordt gebruikt anders dan door de fabrikant gespecificeerd, kan de bescherming, die de apparatuur biedt ongedaan worden gemaakt.
- Alleen die onderdelen mogen worden vervangen die door de fabrikant als uitwisselbaar zijn aangemerkt.
- Alle bedrading moet in overeenstemming zijn met de lokale elektriciteiseisen en moet aangelegd worden door geautoriseerd, ervaren personeel.
- De aardingsdraad moet worden aangesloten vóórdat alle andere bedrading wordt aangesloten (en als laatste worden verbroken).
- Het verdient aanbeveling een netschakelaar aan te brengen vlakbij het instrument.

APPARATUUR VOORWAARDEN

Voedingsspanning	102 tot 132 Vac - 204 to 264 Vac
Frequentie	49 tot 51 Hz - 59 tot 61
Vermogen of stroomvermogen	9 watts max.

OMGEVINGSCONDITIES

Gebruik het instrument niet in de aanwezigheid van ontvlambare vloeistoffen of dampen. Het gebruik van elk elektrisch instrument in een dergelijke omgeving vormt een gevaar voor uw veiligheid.

Temperatuur	In bedrijf : 15 tot 55°C
Vochtigheid	10 tot 90% RH
Trilling	0 tot 70 Hz versnelling 0.1 g

MONTAGE VAN DE APPARATUUR

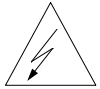
De recorder moet worden gemonteerd in een paneel om de toegankelijkheid tot de achterste aansluitpunten te beperken.

TURVALLISUUSMÄÄRÄYKSET

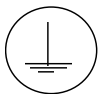
FI2I-6057



Noudata tämän ohjeen kaikkia turvaohjeita välttääksesi sähkötapaturman vaaraa.



Tämä merkki varoittaa käyttäjää sähköiskun vaarasta paikassa, missä voi koskettaa vaarallisia jännitteitä.



Suojamaaliitin. Kytke maadoitsjohdin tähän liittimeen.

- Jos laitetta käytetään olosuhteissa, joihin sitä ei ole suunniteltu, käyttöturvallisuus voi heikentyä.
- Älä vaihda mitään komponenttia tai osaa, jota valmistaja ei ole määritellyt käyttäjän vaihdettavaksi.
- Asennus ja johdotus on tehtävä paikallisten varmuusmääräysten mukaisesti valtuutetun sähköasentajan toimesta.
- Ensimmäiseksi on kytkettävä suojamaa-liitin (ja viimeiseksi irroitettava).
- Laitteen läheisyyteen suositellaan asennettavaksi verkkokytkin.

LAITTEEN VAATIMUKSET

Syöttöjännite	102 - 132 Vac / 204 - 264 Vac
Taajuus	49 - 51 Hz / 59 - 61 Hz
Teho	9 watts

KÄYTTÖOLOSUHTEET

Älä käytä laitetta paikassa jossa on syttyviä nesteitä tai kaasuja, koska laitteen käyttö aiheuttaa räjähdysvaaran.

Lämpötila	ympäröivä : 15 ... 55°C
Kosteus	10 ... 90% RH
Tärinä	0 ... 70 Hz
	Kiihtyvyys 0.1 g

LAITTEEN ASENNUS

Piirturi on asennettava paneeliin siten, että peräliitimille jää riittävästi tilaa.

CONSIGNES DE SECURITE

FR2I-6057



Pour réduire tout risque de décharge électrique qui pourrait provoquer une lésion corporelle, respectez toutes les consignes de sécurité de cette documentation.



Ce symbole avertit l'utilisateur d'un risque électrique potentiel lorsqu'il peut avoir accès à des éléments sous tension.



Borne de mise à la terre. Destinée au raccordement du conducteur de mise à la terre de l'alimentation.

- Si l'équipement est utilisé dans un but non spécifié par le constructeur, la protection fournie avec cet équipement peut être affectée.
- Aucun composant (ou pièce) ne doit être remplacé s'il n'est pas explicitement spécifié comme tel par le constructeur.
- Tous les câblages doivent être conformes aux normes locales et doivent être réalisés par un personnel autorisé et expérimenté.
- La borne de masse doit être raccordée avant tout autre câblage (et débranchée en dernier).
- Il est obligatoire de connecter cet appareil sur une ligne possédant un moyen de coupure près de l'appareil.

CARACTERISTIQUES DE L'EQUIPEMENT

Tension d'alimentation	102 à 132 Vac ou 204 à 264 Vca
Fréquence	49 à 51 – 59 à 61 Hz
Puissance ou courant	9 watts max.

CONDITIONS AMBIANTES

Ne jamais utiliser cet équipement en présence de liquides ou vapeurs inflammables.

L'utilisation de tout instrument électrique dans un tel environnement pourrait présenter un risque pour la sécurité.

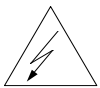
Température	Ambiante : 15 à 55°C
Humidité	10 à 90 % HR
Vibration	Fréquence : 0 à 70 Hz Accélération 0.1 g

INSTALLATION DE L'EQUIPEMENT

Cet appareil doit être monté dans un panneau pour limiter l'accès aux bornes arrières par l'opérateur.

SICHERHEITSHINWEISE

GE2I-6057



Befolgen Sie alle Sicherheitshinweise in diesen Unterlagen, um das Risiko eines Stromschlags zu verringern, der zu Körperverletzung führen kann.



Dieses Symbol warnt den Benutzer vor eventueller Berührungsfahr, wo lebensgefährliche Spannungen zugänglich sein können.



Schützende Erdung. Für den Anschluß der schützenden Erdung der Versorgungssystemleitung.

- Bei Benutzung der Ausrüstungen auf nicht vom Hersteller angegebene Art und Weise kann der von der Ausrüstung gewährleistete Schutz beeinträchtigt werden.
- Ersetzen Sie keine Komponente (oder Teil), die/das nicht ausdrücklich vom Lieferanten als ersetzbar angegeben ist.
- Die gesamte Verkabelung muß den örtlichen Normen entsprechen und von zugelassenem, erfahrenem Personal durchgeführt werden.
- Die Erde muß vor allen anderen Kabeln angeschlossen (und zuletzt abgeklemmt) werden.
- In der Nähe der Ausrüstung muß ein Schalter in der Hauptstromversorgung vorhanden sein.

AUSRÜSTUNGSDATEN

Netzspannung 102 bis 132 Vac oder 204 bis 264 Vac
Frequenz 49 - 51 Hz / 59 – 60 Hz
Nennleistung 9 watts max.

UMGEBUNGSBEDINGUNGEN

Betreiben Sie das Gerät nicht in Gegenwart entflammbarer Flüssigkeiten oder Dämpfe. Der Betrieb elektrischer Geräte in solchen Umgebungen stellt ein Sicherheitsrisiko dar.

Temperatur Umgebung : 15 bis 55°C
Feuchtigkeit 10 bis 90% RH
Vibration 0 bis 70 Hz
Beschleunigung 0.1 g

ANBRINGUNG DER AUSRÜSTUNGEN

Der Regler muß in ein Pult eingebaut sein, damit der Bediener nicht zu oft auf die hinteren Anschlüsse zugreifen muß.

GR2I-6057

NORME DI SICUREZZA

IT2I-6057



Per ridurre i rischi di scariche elettriche che potrebbero causare alle persone, seguire tutte le precauzioni circa la sicurezza indicate in questa documentazione.



Questo simbolo avverte del pericolo di scossa elettrica nelle aree in cui sono accessibili conduttori sotto tensione.



Terminale di protezione verso terra. Previsto per il collegamento del conduttore di protezione verso terra del sistema di alimentazione.

- Se lo strumento viene utilizzato in modo diverso dalla specifica del costruttore, la protezione fornita dallo strumento può essere diversa.
- Non sostituire alcun componente (o parte) non specificato esplicitamente come ricambio dal vostro fornitore.
- Tutti i cablaggi devono essere in accordo con i regolamenti locali e devono essere eseguiti da personale esperto ed autorizzato.
- Il terminale di massa deve essere collegato prima di ogni altro filo (e scollegato per ultimo).
- E necessario che sia presente un interruttore nell'alimentazione principale accanto all'apparecchio.

ALIMENTAZIONE APPARECCHIATURA

Tensione di alimentazione Da 102 a 132 Vac ó da 204 a 264 Vac
Frequenza 49 - 51 Hz / 59 - 61 Hz
Potenza o corrente 9 watts max.

CONDIZIONI AMBIENTALI

Non far funzionare l'apparecchio in presenza di liquidi o gas infiammabili, in quanto questo potrebbe essere estremamente pericoloso.

Temperatura Ambiente : da 15 a 55°C
Umidità relativa Da 10 a 90% UR
Vibrazioni Da 0 a 70 Hz
accelerazione 0.1 g

INSTALLAZIONE DELL'APPARECCHIO

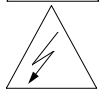
Il apparecchio deve essere montato su un pannello per limitare l'accesso ai terminali posteriori.

SIKKERHETSKRAV

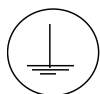
NO2I-6057



Følg alle retningslinjene i dette dokumentet, slik at du reduserer risikoen for elektrisk støt og mulige personskader.



Dette symbolet advarer brukeren om tilgjengelige terminaler med farlige spenninger og en potensiell fare for elektrisk støt.



Jordingsterminal. kabelen for jording av systemet skal tilknyttes til denne terminalen.

- Dersom utstyret benyttes på en måte annerledes enn spesifisert av produsent, kan utstyrets beskyttelsesgrad forringes.
- Ingen komponenter eller deler skal skiftes ut dersom de ikke er uttrykkelig spesifisert som utskiftbare av din forhandler.
- Det er påkrevet med en hovedstrømsbryter i nærheten av utstyret.
- All kabling må utføres i henhold til gjeldende forskrifter og installeres av autoriser og erfaren installatør.
- Jord må tilknyttes før all annen kabling (og frakobles sist).

UTSTYRSPESIFIKASJONER

Strømtilførsel	102 til 132 Vac - 204 til 264 Vac
Nettfrekvens	49 - 51 Hz / 59 – 61 Hz
Kraftforbruk	9 watts max.

OMGIVELSER

Instrumentet må ikke opereres i nærheten av lettantennelige væsker eller gasser. Bruk av elektriske instrumenter i slike omgivelser utgjør en sikkerhetsrisiko.

Temperatur	omgivelse : 15 til 55°C
Fuktighet	10 til 90% HR
Vibrasjon	0 til 70 Hz akselerasjon 0.1 g

UTSTYRSINSTALLASJON

Pass på å montere panelene på regulatoren, slik at berøring av terminalene på baksiden forhindres.

INSTRUÇÕES DE SEGURANÇA

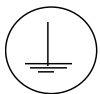
PO2I-6057



Para reduzir o risco de choque eléctrico que pode causar danos corporais, seguir todas as normas de segurança contidas nesta documentação.



Este símbolo avisa o utilizador sobre um eventual perigo de choque quando são acessíveis voltagens sob tensão perigosas.



Terminal de protecção de terra. Fornecido para ligação do condutor do sistema da protecção de terra.

- Se este equipamento for usado de modo não especificado pelo fabricante, a protecção fornecida pelo equipamento pode não ser adequada.
- Não se deve substituir qualquer componente (ou peça) que não seja explicitamente especificado como substituível pelo nosso revendedor.
- Toda a cablagem deve estar de acordo com os códigos eléctricos locais e deve ser realizada por pessoal experiente devidamente autorizado.
- O terminal de terra deve ser ligado antes de ser feita qualquer outra cablagem (e desligado em último lugar).
- Recomenda-se um comutador na fonte de alimentação principal próximo do equipamento.

ESPECIFICAÇÕES DO EQUIPAMENTO

Voltagem	102 a 132 Vac - 204 a 264 Vac
Frequência	49 – 61 Hz / 59 - 61 Hz
Potência ou consumo de corrente	9 Watts max.

CONDIÇÕES AMBIENTAIS

Não operar o instrumento na presença de líquidos ou vapores inflamáveis. A operação de qualquer instrumento eléctrico em tal ambiente constitui um perigo para a segurança.

Temperatura	Ambiente : 15 a 55°C
Humidade	10 a 90% RH
Vibração	0 a 70 Hz aceleração 0.1 g

INSTALAÇÃO DO EQUIPAMENTO

O Registrador deve ser montado num painel para limitar o acesso do operador aos terminais traseiros.

NORMAS DE SEGURIDAD

SP2I-6057



Para reducir el riesgo de choque eléctrico el cual podría causar lesiones personales, seguir todas las indicaciones de este documento.



Este símbolo previene al usuario de un riesgo potencial de descarga cuando se puede acceder a corrientes de tensión peligrosas.



Terminal de tierra de protección. Proporcionado para la conexión de la tierra de protección del conductor del sistema de alimentación.

- Si el equipo es utilizado de forma no especificada por el fabricante, la protección suministrada con el mismo podría resultar dañada.
- No reemplazar ningún componente (o parte) no explícitamente especificado por el suministrador.
- Todo el cableado debe realizarse de acuerdo con las normas eléctricas locales y debe ser realizado por personal experimentado.
- El terminal de tierra debe ser conectado antes que cualquier otro cable y desconectado el último.
- Se recomienda la instalación de un interruptor de la alimentación principal, cerca del equipo.

DATOS ELECTRICOS DEL EQUIPO

Tensión de alimentación 102 a 132 Vac - 204 a 264 Vac
Frecuencia 49 - 51 Hz / 59 - 61 Hz
Potencia o corriente 9 watts max.

CONDICIONES AMBIENTALES

No operar con el instrumento en presencia de líquidos o gases inflamables. La operación de cualquier equipo eléctrico en tal ambiente constituye un riesgo contra la seguridad.

Temperatura Ambiente : 15 a 55°C
Humedad 10 a 90% RH
Vibración 0 a 70 Hz
aceleración 0.1 g

INSTALACION DEL EQUIPO

Este equipo debe ser montado en un panel para limitar al operador el acceso a los terminales traseros.

SÄKERHETSFORESKRIFTER

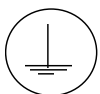
SW2I-6057



För att reducera riskerna av elektriska chocker som kan orsaka personsador, följ alla säkerhetsföreskrifter i denna dokumentation.



Denna symbol varnar användaren för risk för elchock vid tillfällig åtkomst av spänningsförande del.



Anslutning av skyddsjord. Avsedd för anslutning av elsystemets skyddsjordsledare.

- Om utrustningen används på ett sådant sätt, att det inte innefattas av tillverkarens specifikation, kan de inbyggda säkerhetsfunktionerna äventyras.
- Ersätt aldrig någon komponent (eller del) som inte är specificerad som ersättningsbar av tillverkaren.
- All ledningsdragnings måste utföras i enlighet med lokala bestämmelser och skall utföras av behörig personal med erfarenhet av sådant arbete.
- Skyddsjordsanslutningen skall anslutas före alla andra anslutningar (och losskopplas sist).
- En strömbrytare för näströmmen rekommenderas.

STRÖMFÖRSÖRJNING

Spänning 102 a 132 Vac - 204 a 264 Vac
Frekvens 49 - 51 Hz / 59 - 61 Hz
Effekt eller märkström 9 watts max.

OMGIVNINGSVILLKOR

Använd ej instrumentet i närhet av brännbara vätskor eller gaser. Användandet av instrumentet i sådant miljö är en direkt säkerhetsrisk.

Temperatur Omgivande : 15 till 55°C
Fuktighet 10 till 90% RH
Vibration 0 till 70 Hz
acceleration 0.1 g

INSTALLATION

Instrumentet skall monteras i en panel eller i en låda för att undvika att personalen kommer i beröring med bakre inkopplingsplintar.

11. Index

- 0**
- 0-10 Volt dc inputs, 37
 - 0-10 Volt inputs, 190
- 4**
- 4-20 mA auxiliary output wiring, 52
 - 4-20 mA control output wiring, 39
 - 4-20 mA input wiring, 35
 - 4-20 mA inputs, 191
- A**
- AC line power, 30
 - Accutune II, 141
 - Alarm hysteresis, 73, 110
 - Alarm messages, 129
 - Alarm outputs, 45
 - Alarm setpoints, 144
 - Alarms group definitions, 109
 - Atmospheric pressure compensation, 76, 114
 - Automatic calibration mode, 199
 - Automatic local mode, 131
 - Automatic mode
 - Return to, 132, 162
 - Selecting, 132
 - Automatic remote mode, 131
 - Automatic switchover, 93
 - Automatic switchover value, 67, 94
 - Auxiliary Output, 73, 74
- B**
- Basic recorder components without options, 227
 - Battery test failure, 211
 - Baud rate, 75
 - Bias, 95
 - Bias for remote setpoint, 67
 - Burnout, 63
 - Burnout protection, 87
- C**
- Calibration procedure, 192
 - Calibration set up, 184
 - 0-10 Volt inputs, 190
 - 4-20 mA inputs, 191
 - Millivolts and Volts inputs (except 0-10 Volts), 189
 - RTD inputs, 188
 - Thermocouple inputs using a compensated calibrator method, 186
 - Thermocouple inputs using an ice bath, 185
 - Thermocouple inputs using the ambient temperature method, 187
- D**
- CE Conformity (Europe), 1
 - CE Conformity special conditions, 7
 - CE conformity special conditions (Europe), 27
 - Chart high range value, 88
 - Chart lamp, 149
 - Replacing, 149
 - Chart low range value, 88
 - Chart plate assembly parts, 225
 - Chart speed selection, 65
 - Chart time line, 120
 - CHN indicator, 130
 - Circuit-breaker, 30
 - Communications station address, 75, 113
 - Condensed specifications, 8
 - Configuration procedure, 60
 - Configuration prompts, 56
 - Configuration tips, 59
 - Control algorithm, 68, 98
 - Control output direction, 67, 96
 - Controller dropoff value, 67, 96
 - Current proportional output calibration, 196, 201
 - Current simplex, 100
 - Current/relay duplex, 100
 - Current/time duplex range, 68
 - Customer support, 205
 - Cycle time (heat), 104
 - Cycle time 2 (cool), 104
- E**
- Deadband, 68, 96
 - Decimal point location, 62, 84
 - Deviation, 114
 - Deviation bargraph, 126
 - Deviation recording action, 76
 - Deviation setpoint value, 76, 114
 - Device status, 208
 - Diagnostic error messages, 128
 - Diagnostic tests, 120
 - Digital inputs, 45
 - Dimensions, 16
 - Direct acting control, 96
 - Display test, 121
 - Displaying totalizer value, 147
 - Displays, 3
- E**
- Electrical alignment, 221
 - Electrical noise, 27
 - Emissivity, 63
 - Engineering units, 84
 - Error message

- BATT LOW. *See*
 BATTERY, 211
 CAL TEST, 210
 CAL1 ERR, 210
 CAL2 ERR, 210
 CONFTEST, 209
 EE FAIL, 211
 FACT CRC, 210
 FAILSAFE, 209
 INxFAIL, 211
 PV LIMIT, 211
 RAM TEST, 209
 RV LIMIT, 211
- Error message prompts, 209
 Error messages, 128
 Event pen function, 148
 Event pen operation, 148
- F**
- Factory calibration, 178
 Failsafe, 207
 Failsafe output value, 68
 Failure symptoms, 205
 Ferrite filter locations (CE Mark), 29
 Field wiring, 181
 Filter, 63, 87
- G**
- Gain, 103
 Gain 2, 104
 Gain units, 68
 Grid line contrast, 122
- H**
- Hardware kit contents, 231
 Heavy Duty door mounting, 22
 High output limit, 67, 96
 High range value, 63, 86
 High setpoint limit, 67
 Hours per revolution, 90
 Hysteresis, 68, 96, 110
- I**
- Ice bath, 182
 Indicators, 3
 Input 1 actuation type, 62
 Input actuation type, 85
 Input compensation, 63, 87
 Input out of range, 212
 Input terminals, 181
 Inputs
 0–5 Vdc, 33
 Radomatic, mV, 33
 RTD, 33
 Thermocouple, 33
 Installation
 Operating limits, 8
 Preinstallation information, 7
 Installing chart, 150
 Internal cabling, 232
- J**
- Jumper positions, 183
- K**
- Key test, 121
 Knockout locations, 17
- L**
- Local setpoint, 133
 Local setpoint, 94
 Lockout, 77, 116
 Low flow cutoff selection, 63
 Low output limit, 67, 96
 Low range value, 63, 87
 Low setpoint limit, 67
- M**
- Maintenance, 149
 Manual calibration mode, 199
 Manual mode, 131
 Adjusting output, 132, 133, 161, 162
 Selecting, 132
 Manual reset, 103
 Minutes per repeat, 98
 Monitoring your recorder, 123
 Motor traverse time, 199
 Mounting
 Overall dimensions, 16
 Mounting methods, 17
 2-inch pipe, 24
 Flush in panel, 18, 20
 Flush in panel, 21
 Heavy Duty door, 22
 Surface, 25
- O**
- ON/OFF algorithm, 98
 Operating limits, 8
 Operating modes, 131
 Operating parameters, 127
 Operator functions, 130
 Operator interface, 3, 123
 Output algorithm, 68, 100
 Output wiring for alarms 3 and 4, 47
 Output wiring for alarms 5 and 6, 48
- P**
- Parts lists, 223
 PD with manual reset, 99
 Pen Set Up group, 64

Pen tip, *149*
Physical considerations, *16*
PID A, *99*
PID B, *99*
PID sets, *140*
Pipe mounting, *24*
Position proportional control output wiring, *41*
Position proportional output calibration, *198*
Position proportional simplex, *100*
Power supply mains, *30*
Power up controller mode recall, *67, 95*
Power up diagnostic tests, *120*
Power-up tests, *207*
Prompt hierarchy, *56*
Proportional band, *103*
Proportional band 2, *104*
Proportional band units, *97*

R

Radiamatic, millivolts, and volts inputs (except 0–10 Volts), *189*
Ramp/soak program, *106*
Rate 2, *104*
Rate action, *103*
Rate of integration, *66, 92*
Ratio, *94*
Ratio for remote setpoint, *67*
Recorder components associated with options, *229*
RECYCL parameter, *163*
Rejection frequency, *73, 76, 114*
Relative humidity, *76, 114*
Relay control output wiring, *43*
Relay duplex, *100*
Relay/current duplex, *101*
Remote setpoint, *94*
Remote switching, *145*
Repeats per minute, *98*
Replace the chart, *118*
Replacing chart, *150*
Reset, *103*
Reset 2, *104*
Reset units, *68, 98*
Resetting totalizer value, *146*
Resistance equivalent, *180*
Restoring factory calibration, *178*
Reverse acting control, *96*
RS485 Modbus communications wiring, *50*
RSP, *134*
RTD inputs, *188*

S

Safety Requirements for Electrical Equipment, *27*
Self diagnostics, *205*
Setpoint high limit, *95*
Setpoint low limit, *96*
Setpoint Program
 Data entry, *161*
 event setup, *170*
 overview, *151*

 ramp setup, *163*
 run/monitor functions, *174*
 segment setup, *165, 167*
Setpoint ramp, *105*
 Configuring, *135*
 Running, *136*
Setpoint ramp final setpoint, *106*
Setpoint ramp time, *106*
Setpoint selection indication, *134*
Setpoint source, *67, 94, 133*
Setpoint tracking, *67, 95*
Set-up tasks, *5*
Shield wiring, *29*
Single setpoint ramp, *105, 135*
SOKDEV parameter, *163*
SPPROG parameter, *163*
Start up, *122*
Stylus, *122*
Suppression filters, *29*
Switchover value, *139*

T

Temperature units, *62, 84*
Thermocouple inputs using a compensated calibrator method, *186*
Thermocouple inputs using an ice bath, *185*
Thermocouple inputs using the ambient temperature method, *187*
Totalizer, *66*
Totalizer group definitions, *91*
Totalizer reset, *66, 67*
Totalizer scale factor, *66*
Totalizer value, *146*
 Displaying, *147*
 Resetting, *146*
Trace line contrast, *122*
Transmitter characterization, *63, 86*
Troubleshooting procedures, *214*
Transmitter power, *35*
Tuning constants, *138*
Tuning group prompt definitions, *102*
Tuning messages, *129*
Tuning parameter sets, *67, 93*
Two local setpoints, *94*
Two sets of tuning constants, *138*

V

Visual failure symptoms, *205, 213*
Voltage equivalent, *180*

W

Wire bundling, *28*
Wiring
 0-10 Vdc inputs, *37*
 0-5 Vdc inputs, *33*
 4-20 mA auxiliary output, *52*
 4-20 mA control output, *39*
 4-20 mA inputs. *See*

AC line power. *See*
Electrical noise precautions, 27
mV inputs, 33
Position proportional control output, 41
Radiamatic inputs, 33
Relay control output, 43
RS485 Modbus communications, 50
RTD inputs, 33
Shields, 29
Thermocouple inputs, 33
Transmitter power. *See*
Wire bundling, 28
Wiring the recorder, 29
Wiring for PV inputs, 184
0-10 Volt inputs, 190
4-20 mA inputs, 191
Millivolts and Volts inputs (except 0-10 Volts), 189
RTD inputs, 188
Thermocouple inputs using a compensated calibrator
method, 186
Thermocouple inputs using an ice bath, 185
Thermocouple inputs using the ambient temperature
method, 187



Honeywell

AUTHORIZED DISTRIBUTOR

**De Gidts & Feldman BV
The Netherlands
www.dgfg.nl**



De Gidts & Feldman

INSTRUMENTATION & FILTRATION

Honeywell

Honeywell Field Solutions

Honeywell

512 Virginia Drive

Ft. Washington, PA 19034

44-45-25-35 Rev. J 06/07 Printed in USA

<http://hpsweb.honeywell.com>