

DC1010 - DC1020 - DC1030 - DC1040 General Purpose DIGITAL CONTROLLERS

PRODUCT SPECIFICATION SHEET

OVERVIEW

The DC1000 family of microprocessor based controllers combine a high degree of functionality and reliability at a very low price. Available in 4 different formats : 1/16 DIN, 1/8 DIN, 3/16 DIN, 1/4 DIN. These controllers are ideal for regulating temperature in a variety of applications, including :

- Dryers.
- Semiconductor packaging / testing.
- Plastic processing.
- Packaging machinery.
- Painting and coating.
- Climatic chambers.

The DC1000 family provides basic control requirements, plus advanced features such as motor position control, phase angle power control and Setpoint programming.

FEATURES

Easy to configure

Two different configuration levels provide easy access to parameters. A 4-digit security code prevents unauthorized changes. Parameters can also be hidden to the user to prevent mis-configuration of the unit.

Various Control algorithms

The DC1000 series of controllers provide several different algorithms:

- PID or ON/OFF control.
- Heat/Cool algorithms with 2 different PID sets.
- Motor position control without slidewire feedback.
- Single phase control, with or without zero crossover control.
- Three phase control, with or without zero crossover control.

Dual display and Bargraph

Two large 4 digits displays and one 10 LED bargraph display PV, SP and configuration parameters. Up to 8 LEDs display the status of the different Outputs (Control, Alarm, ...) and also provides indication of the Auto/Manual and Programmer states.

Setpoint Programming

Two programs are available, with a maximum of 8 segments per program. The 2 programs can be linked together to form a single 16 segment program.

Extended Alarm capability

Three different alarm outputs are available per instrument, 17 alarm modes are configurable.

Autotuning capability.



DC1020 (1/8 DIN)



DC1010 (1/16 DIN)



DC1030 (3/16 DIN)



DC1040 (1/4 DIN)

Communications

RS232 or RS485 Modbus rtu/ASCII protocol is optionally available. Upto 30 DC1000 Controllers can be connected to a single host computer. The host computer can change the SP, monitor the PV, the output or change the configuration of the unit.

Remote Setpoint capability.

Manual / Automatic modes.

Universal Power supply

Operates on any voltage from 85Vac to 264Vac at 50/60Hz. 24Vdc operating voltage is optional.

Operating range

These instruments operate, from 0°C to +50°C (32°F~122°F)
Humidity=50 to 85% RH

SPECIFICATIONS

Technical data

PV Input	Type of Input	Thermocouples : K, J, R, S, B, E, N, T, W, PL II, U, L
		RTD : Pt100, JPt100, JPt50
		Linear : 4~20mA
	Input Sampling Time	250 ms
	Input Resolution	14 bit (each)
Indication	PV/SP Indication	4-digit, 7 segment display
	Constant Value Storage System	Non-volatile memory (EEPROM)
	Indication Accuracy	+/-0.2%FS
Control Mode	Proportional Band (P)	0~200% (On/Off action at P=0)
	Integral Time (I)	0~3600 sec (PD action at I=0)
	Derivative Time (D)	0~900 sec (PI action at D=0)
	Cycle Time	0~150 sec (4~20mA=0, SSR=1, Relay=10)
	Dead Band Time	0~1000 sec (dead time compensation)
Output	Relay Output	Electromechanical relay <ul style="list-style-type: none"> • SPDT contacts (DC101 :SPST) • 3A/240Vac
	Static relay driver output	Voltage Pulse, 20VDC/20mA
	Current & Voltage outputs	0~20mA, 4~20mA, 0~5V, 0~10V, 1~5V, 2~10V
	Motor Control Output	Servo motor valve control (open loop circuit)
	Others	Phase angle control : ✓ 1φ SSR, 3φ SSR, 1φ SCR, 3φ SCR
Alarm	Number	Up to 3 (optional, DC101 :2sets)
	Modes	17 alarm modes available, hability to ignore the alarm the first time it occurs : <ul style="list-style-type: none"> ✓ Deviation high or low alarms. ✓ Deviation alarms. ✓ Band alarm. ✓ High or low alarm. ✓ End of segment alarm. ✓ Program run indication alarm. ✓ Timer alarm.
	Timer	One timer is associated with each alarm.
Retransmission output	Output Signal	SP, PV
	Type of Output	4~20mA, 0~20mA, 0~5V, 0~10V, 1~5V, 2~10V

2nd Input (Remote SP)	Type of Input	4~20mA, 0~20mA, 0~5V, 0~10V, 1~5V, 2~10V
	Sampling Time	500 ms.
Programs	Number	2 programs of 8 segments each.
Communication	Type of Communication	RS-232 or RS-485. Modus rtu(HE), Modbus ASCII
	Specification	Parity= Odd/Even, Data bit= 8bits, Stop bit=1 or 2 bit
	Communication Speed	2400,4800,9600,19200,38400 bps
Operating conditions	Rated Power Supply Voltage & Frequency	AC 85 ~ 265V, 50/60Hz DC24V(optional)
	Power Consumption	8VA (110V), 12VA (220V)
	Ambient Temperature	-20°C ~ 65°C (-4°F ~ 149°F)
	Ambient Humidity	50 ~ 85% RH (non condensing)
Approvals		UL (QUXY2-E201698) CE Mark.

TC & RTD Types & ranges

		°C			°F		
TC	K	0.0~200.0 °C	0.0~400.0 °C	0.0~600.0 °C	0.0~392.0 °F	0.0~752.0 °F	0~1112 °F
		0~800.0 °C	0~1000 °C	0~1200 °C	0~1472 °F	0~1832 °F	0~2192 °F
	J	0.0~200.0 °C	0.0~400.0 °C	0.0~600.0 °C	0.0~392.0 °F	0.0~752.0 °F	0~1112 °F
		0~800 °C	0~1000 °C	0~1200 °C	0~1472 °F	0~1832 °F	0~2192 °F
	R	0~1600 °C	0~1769 °C		0~2912 °F	0~3216.0 °F	
	S	0~1600 °C	0.0~1769 °C		0~2912 °F	0~3216.0 °F	
	B	0~1820 °C			0~3308 °F		
	E	0~800 °C	0~1000 °C		0~1472 °F	0~1832 °F	
	N	0~1200 °C	0~1300 °C		0~2192 °F	0~2372 °F	
	T	-199.9~400.0 °C	-199.9~200.0 °C	0.0~350.0 °C	-199.9~752.0 °F	-199.9~392.0 °F	0.0~662.0 °F
	W	0~2000 °C	0~2320 °C		0~3632 °F	0~4208 °F	
PL II	0~1300 °C	0~1390 °C		0~2372 °F	0~2372 °F		
U	-199.9~600.0 °C	-199.9~200.0 °C	0.0~400.0 °C	-199.9~999.9 °F	-199.9~392.0 °F	0.0~752.0 °F	
L	0~400 °C	0~800 °C		0~752 °F	0~1472 °F		
RTD	Pt 100	-199.9~600.0 °C	-199.9~400.0 °C	-199.9~200.0 °C	-199.9~999.9 °F	-199.9~752.0 °F	-199.9~392.0 °F
		0~200 °C	0~400 °C	0~600 °C	0~392 °F	0~752 °F	0~1112 °F
	JPt 100	-199.9~600.0 °C	-199.9~400.0 °C	-199.9~200.0 °C	-199.9~999.9 °F	-199.9~752.0 °F	-199.9~392.0 °F
		0~200 °C	0~400 °C	0~600 °C	0~392 °F	0~752 °F	0~1112 °F
	JPt 50	-199.9~600.0 °C	-199.9~400.0 °C	-199.9~200.0 °C	-199.9~999.9 °F	-199.9~752.0 °F	-199.9~392.0 °F
		0~200 °C	0~400 °C	0~600 °C	0~392 °F	0~752 °F	0~1112 °F

Control Algorithms

- PID or ON/OFF control.
- Heat/Cool algorithms with 2 different PID sets.
- Phase angle control

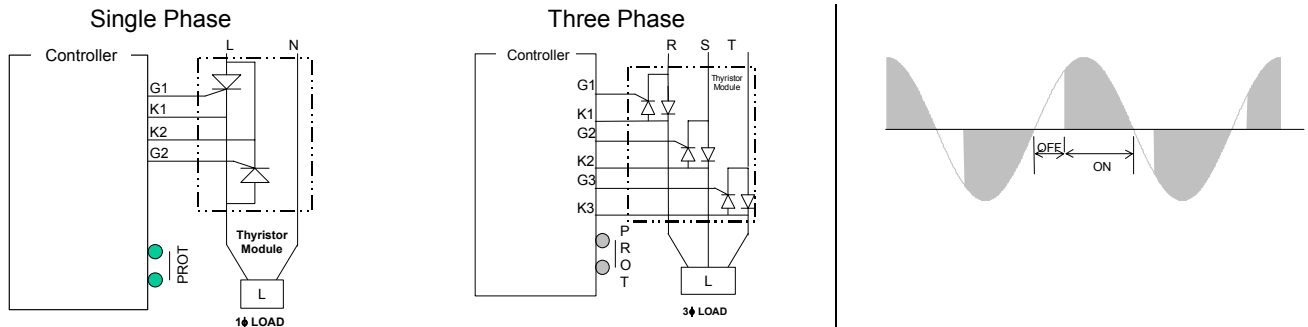

In phase angle control, power is regulated by changing the point at which the SCR is turned on within each 1/2 period.

Single Phase : Output is changed every half-cycle in response to output signals from the Temperature Controller.

Three Phase : The outputs are changed every 120° in response to signals from the Temperature Controller.

Using this form of control, high-precision temperature control is possible.

- Zero-crossover control

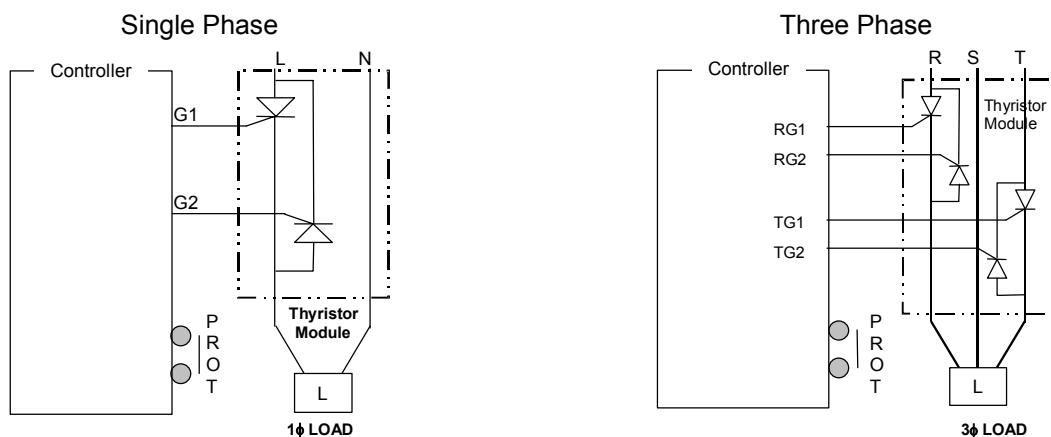

The term Zero-Crossover means that the SCR's are turned on only when the instantaneous value of the sinusoidal wave is zero. Power is then applied for a several continuous half-cycles and then removed for several half-cycles to achieve the desired load power.

- Motor position control without slidewire Feedback.

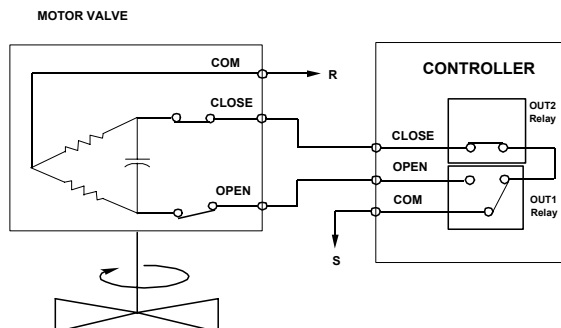

Motor position is achieved by using time proportional control without the need for slidewire feedback from the motor shaft.

Slidewires wear over a period of time, which can result in poor or intermittent control. This type of control reduces maintenance requirements and removes the need for the controller to be calibrated to the motor feed back potentiometer.

EXTERNAL DIMENSIONS, PANEL CUTOUT

DC1010

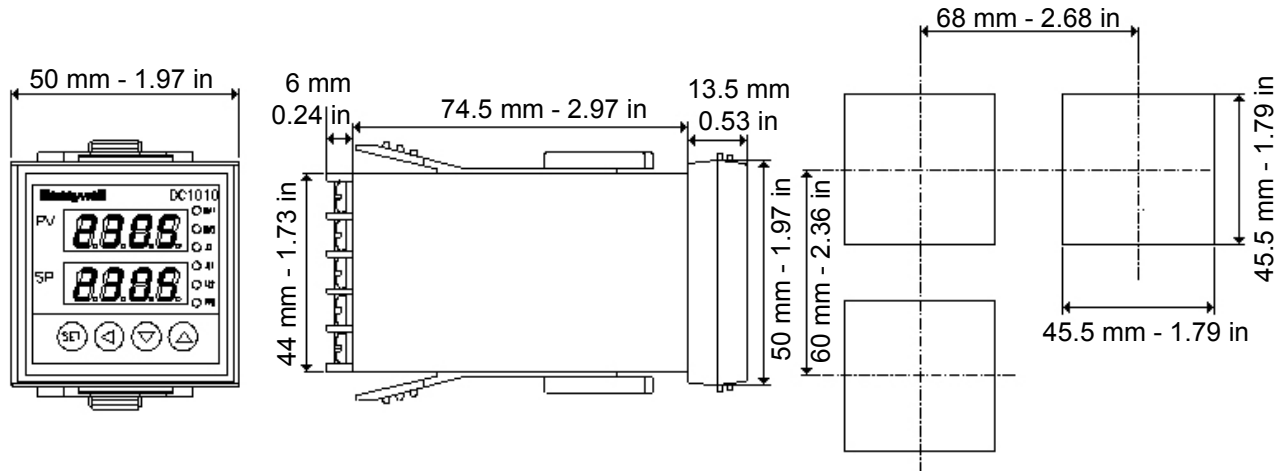

DC1020

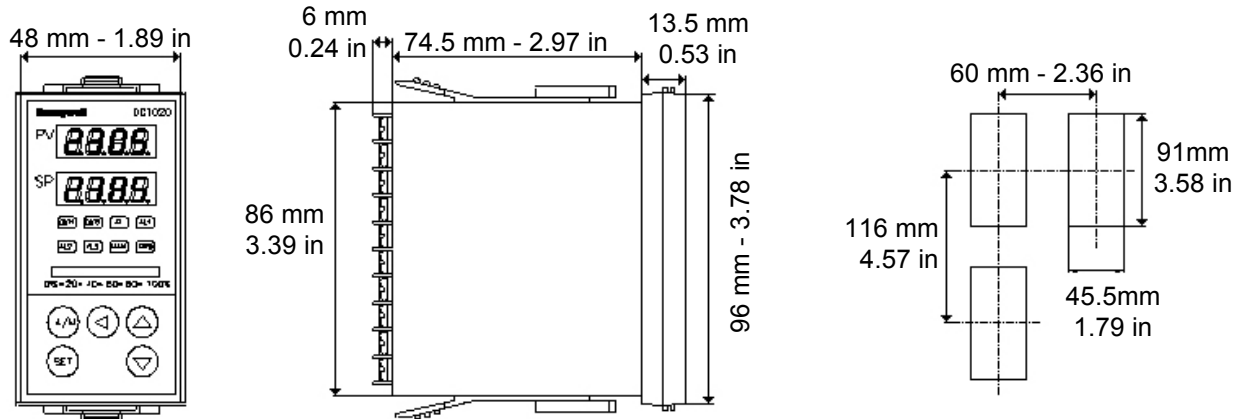

DC1030

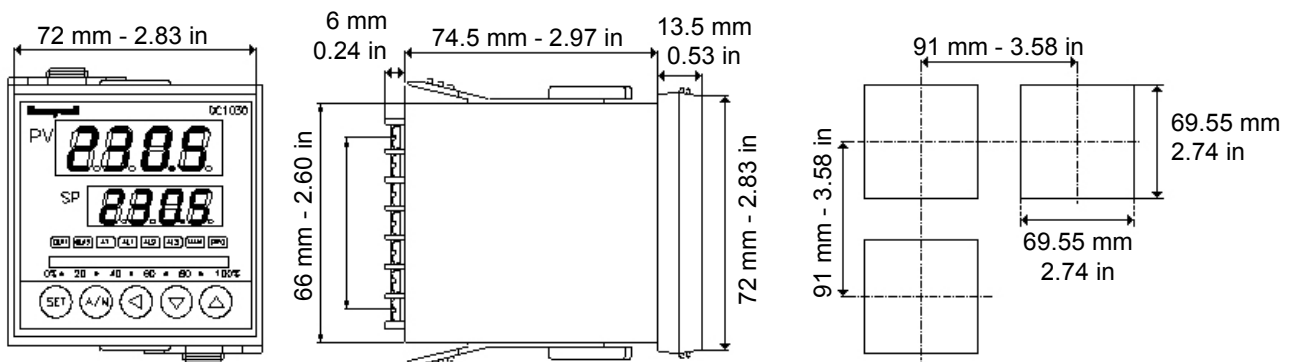

EXTERNAL DIMENSIONS, PANEL CUTOUT

DC1040

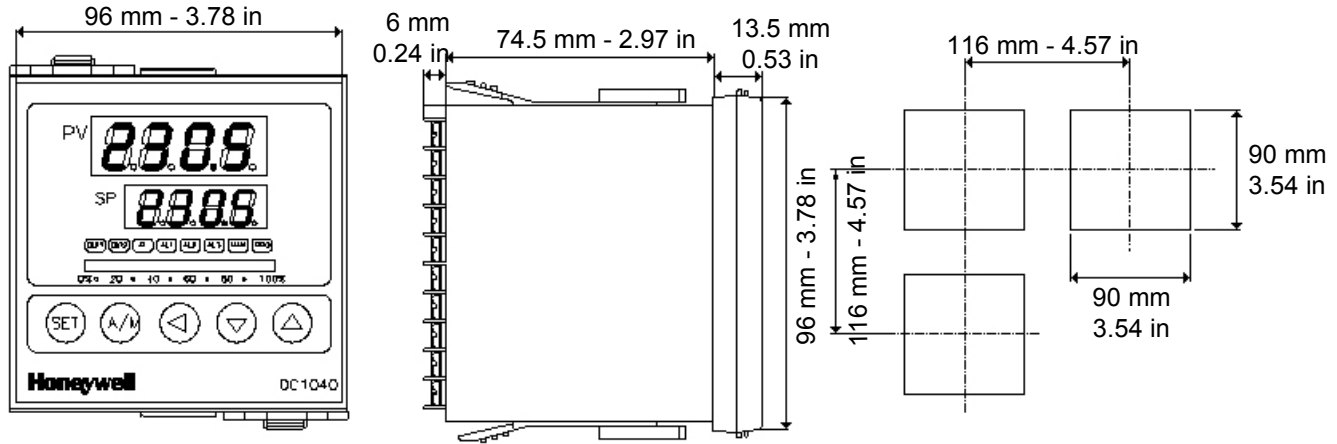

HUMAN / MAN INTERFACE

Higher display : 4 digits dedicated to display the PV. In configuration mode, this display indicates the value of the parameter or the parameter selected.

Lower display : 4 digits dedicated to display the SP ; In configuration mode, indicates the name of the parameter.

Bargraph : A 10 green LEDs bargraph indicates the value of the output in percentage.

LEDs :

OUT1 : Status of output 1.

OUT2 : Status of output 2.

AT : When the LED is ON an automatic tuning of the parameters is on going.

AL1 : Status of alarm 1.

AL2 : Status of alarm 2.

AL3 : Status of alarm 3.

MAN : ON if we are in Auto mode. OFF if manual mode.

PRO : Flickers when a program is running.
Continuously ON when a program is suspended.
OFF when no program is running.

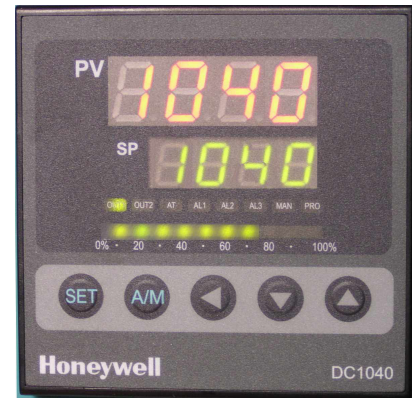

SET allows to change from one parameter to another. Pressing it for 5 seconds grants access to the configuration level 1 (PID parameters+locking the instrument). Pressing simultaneously for 5 seconds on the left arrow and SET grants access to the configuration level 2 (input type, alarms, SP limits, field calibration, communication parameters, ...).

A/M allows to switch from Auto to Manual.

Pressing this key decreases the parameter or digit being modified.



When modifying a parameter, pressing this key allows to change the digit to modify.



Pressing this key increases the parameter or digit being modified.

MODEL SELECTION GUIDE

- Select the desired Key Number.
- Make One selection each from Tables I through III.

Key Number **DC10** - -

Dimension	Power&Approval
1 48*48mm	0 90-240Vac/CE
2 48*96mm	1 24-50Vdc/CE
3 72*72mm	2 90-240Vac/IP65/CE
4 96*96mm	3 24-50Vdc/IP65/CE
	4 90-240Vac/IP65/CE/UL
	5 24-50Vdc/IP65/CE/UL

Program	Input
C None	R RTD
P Program	T TC
	L Linear

Table III	
Manual	
E	English
F	French
I	Italian
G	German
S	Spanish

Table I		
Output 1	Output 2	Alarm
0 None	0 None	0 None
1 Relay	1 Relay	1 1 alarm
2 Voltage	2 Voltage	2 2 alarms
3 4~20mA	3 4~20mA	3 3 alarms
5 1 φ SSR	A 0~5V	
6 3 φ SSR	B 0~10V	
7 Motor V	C 1~5V	
8 1 φ SCR	D 2~10V	
9 3 φ SCR		
A 0~5V		
B 0~10V		
C 1~5V		
D 2~10V		

Table II		
Aux. Output	2nd Input	Comm.
0 None	0 None	0 None
1 4~20mA	1 4~20mA	1 RS232
2 0~20mA	2 0~20mA	2 RS485
A 0~5V	A 0~5V	
B 0~10V	B 0~10V	
C 1~5V	C 1~5V	
D 2~10V	D 2~10V	

Distributor :



Honeywell
AUTHORIZED DISTRIBUTOR

De Gidts & Feldman BV
The Netherlands
www.dgf.nl

De Gidts & Feldman
INSTRUMENTATION & FILTRATION

Industrial Measurement and Control

Honeywell Inc.

Japan : Industrial Operations Tokyo, 4-28-1 Nishi-Rokugo Othu-ku, Tokyo 144, Japan,

Asia : Honeywell Asia Pacific Inc., Room 3213-3225, Sun Hung Kai Centre, No. 30 Harbour Road, Wanchai, Hong Kong

Pacific Division : Honeywell Pty Ltd., 5 Thomas Holt Drive, North Ryde NSW Australia 2113

Northern Europe and Southern Africa : Honeywell Ltd., Honeywell House, Arlington Business Park, Bracknell, RG 12 1 EB, U.K.

Central Europe : Honeywell A.G., Kaiserleistraße 39, 63067 Offenbach, Germany

Western and Southern Europe : Honeywell S.A., Bourgetlann 1, 1140 Brussels, Belgium

Eastern Europe : Honeywell Praha, s.r.o., Budejovicka1, 140 00 Prague 4, Czech Republic

Middle East : Honeywell Middle East Ltd., Khalifa Street, Sheikh Faisal Building, Abu Dhabi, U.A.E